

# **Aerial Application**

**A Training Manual for Pilots Seeking Licensure  
as Certified Pesticide Applicators**

**Thomas W. Dean**  
*June 2001*



# **Aerial Application**

**A Training Manual  
for  
Pilots Seeking Licensure  
as  
Certified Pesticide Applicators**



## Acknowledgments

Although the phrasing the reader encounters throughout is mine, without question, this manual's fundamental content pointedly reflects the work and knowledge of several authors, educators, researchers and others who have contributed to the fields of aircraft delivery of pesticide, spray drift management, pesticide application technology, and aerial applicator training. Were I to exclude all that I've learned from their published works, reviews, critiques and personal communications; little of substance would remain. The principals of this helpful group to which I remain perpetually indebted include:

Peter H. Dana, Ph.D., University of Colorado  
Donnie Dipple, Ph.D., Texas Dept. of Agriculture  
Dennis R. Gardisser, Ph.D., University of Arkansas  
Andrew Hewitt, Ph.D., Stewart Ag. Research Services, Inc.  
Jeff Jenkins, Ph.D., Oregon State University  
William A. Kirby, Inspector; FAA (ret.)  
Dennis L. Kuhlman, Ph.D., Kansas State University  
Dean A. Morss, Ph.D., Creighton University  
O Norman Nesheim, Ph.D., University of Florida  
Ronald L. Noyes, Ph.D., Oklahoma State University  
John Impson, Ph.D., USDA (ret.)  
David L. Valcore, Ph. D., Dow Agrosiences  
Joel T. Walker, Ph.D., University of Arkansas

In addition to those expressly mentioned, I offer warm thanks and heartfelt appreciation to each of the many pilots, engineers, innovators, reseachers, teachers, writers, and others throughout the country who, since 1921, have made it their work to further the technology, science, and safety of aerial pesticide application.

Last but certainly not least, I extend sincere gratitude to the leadership of the Cooperative State Research, Education, and Extension Service (CSREES) of the United States Department of Agriculture (USDA), for its unflagging support of this manual's production via CSREES Project Number 97-EXCA-1-0587.

*Thomas W. Dean, Ph.D.  
Pesticide Information Office  
University of Florida  
June 2001*



# Table of Contents

<b>Introduction</b> .....	<b>1</b>
<b>Chapter 1. Regulations</b> .....	<b>3</b>
14 CFR: Aeronautics and Space .....	3
14 CFR 137: Agricultural Aircraft Operations .....	4
Subpart A - General .....	4
Subpart B - Certification Rule .....	4
Subpart C - Operating Rules .....	7
Subpart D - Records and Reports .....	12
Other Federal Rules .....	13
State Laws and Rules .....	13
The Label as Law .....	14
Review Questions for Chapter 1 .....	15
<b>Chapter 2. Pesticides and Human Health</b> .....	<b>19</b>
Introduction .....	19
Exposure .....	19
Dosage .....	20
Toxicity .....	21
Signs and Symptoms .....	22
Cholinesterase Tests .....	23
First Aid for Pesticide Overexposure Victims .....	23
Pesticide on the Skin .....	23
Chemical Burn (Blistered Skin) .....	24
Pesticide in the Eye .....	24
Inhaled Pesticide (Dusts, Aerosols, Vapors, Gases) .....	24
Swallowed Pesticide .....	25
Traumatic Shock .....	25
First Aid Equipment .....	26
Medical Antidotes .....	26
Review Questions for Chapter 2 .....	27

<b>Chapter 3. Application Equipment</b> .....	<b>31</b>
Dispersal Systems .....	31
Liquid Dispersal .....	31
Tanks .....	32
Pumps .....	32
Agitation .....	33
Filters and Screens .....	34
Piping and Fittings .....	34
Pressure Gauge .....	35
Spray Booms .....	35
Nozzles .....	36
Cone-Pattern Nozzles .....	36
Fan-Pattern Nozzles .....	37
CP Nozzles .....	39
Rotary Atomizers .....	41
Spray System Operating Pressure .....	41
Nozzle Anti-Drip Devices .....	41
Dry Dispersal .....	43
Ram-Air Spreader .....	43
Feed Rate .....	44
Spreader Vanes .....	44
Spreader Mounting .....	46
Rate and Swath .....	47
Centrifugal Spreader .....	47
Review Questions for Chapter 3 .....	48
<b>Chapter 4. Drift Management</b> .....	<b>53</b>
Definition of "Pesticide Drift" .....	53
Why be Concerned About Drift? .....	54
Droplet Size .....	54
Equipment Factors Affecting Droplet Size .....	56
Nozzle Type .....	56
Orifice Diameter .....	56
Spray Pattern Angle .....	56
Nozzle Mounting Angle .....	57
Travel Speed .....	57
Spray Pressure .....	57
Operational Parameters .....	58
The Effect of Formulation .....	58
Spray Adjuvants .....	59



Tank Mix Composition .....	60
Weather Factors .....	60
Wind Velocity .....	60
Atmospheric Stability .....	61
Stability Ratio (SR), Calculation Example .....	62
Temperature .....	63
Relative Humidity .....	63
Microweather .....	63
Spray Drift Management Record .....	65
Review Questions for Chapter 4 .....	66
<b>Chapter 5. Navigation .....</b>	<b>71</b>
Navigation Methods .....	71
GPS - (Global Positioning System) .....	72
GPS: Background and Purpose .....	72
GPS: Overall System Structure and Function .....	72
Space Segment .....	72
Control Segment .....	73
User Segment .....	73
How GPS Works .....	74
Differential GPS .....	74
Maritime DGPS .....	75
Nationwide DGPS .....	76
WAAS .....	77
Commercial DGPS Services .....	77
OmniSTAR® .....	77
DGPS Consumer Issues .....	78
Using DGPS during Aerial Application .....	79
Using the GPS Lightbar .....	79
Other GPS Equipment Features for Ag Aircraft .....	80
A Cautionary Word .....	80
Review Questions for Chapter 5 .....	81
<b>Chapter 6. Calculating the Area of a Target Site .....</b>	<b>85</b>
Introduction .....	85
Regularly-shaped Areas .....	85
Rectangular Sites .....	85
Circular Sites .....	87
Triangular Sites .....	89
Irregularly-shaped Sites .....	91
Review Questions for Chapter 6 .....	95

<b>Chapter 7. Calibration Procedures</b> .....	<b>97</b>
Initial Factors .....	97
Independent Factor #1: Boom Discharge Rate .....	97
Independent Factor #2: Treatment Progress Rate .....	98
Altering Nozzle Configuration .....	98
Selecting nozzle tip size .....	100
Determining total nozzles needed .....	101
Swath Width .....	101
Pattern Testing a Spray Boom .....	101
Pattern Testing a Ram-Air Spreader .....	106
Determining Swath Width .....	106
Calibration with Existing Nozzles .....	108
Determining Boom Output Rate (gpm) .....	109
Determining Treatment Progress Rate (apm) .....	109
Determining Spray Volume Rate (gpa) .....	110
Field Confirmation of System Performance .....	110
Review Questions for Chapter 7 .....	113
<b>Chapter 8. Pesticide Measurement Systems</b> .....	<b>117</b>
Introduction .....	117
Types of Measure .....	117
Units of Measure Commonly Used in Pesticide Work .....	118
Measurement Unit Conversion .....	119
Review Questions for Chapter 8 .....	122
<b>Chapter 9. Using a Dry Formulation to Prepare a Spray</b> .....	<b>125</b>
Introduction .....	125
Situation 1: Label rate stated as pounds of formulated product .....	126
Case A: Pounds of product per 100 gallons of water .....	126
Case B: Pounds of product per unit area of target site .....	129
Situation 2: Label rate stated as pounds of active ingredient .....	135
Case A: Pounds of active ingredient (AI) per 100 gallons of water .....	136
Case B: Pounds of active ingredient (AI) per acre .....	137
Situation 3: Label rate stated as percent active ingredient (%AI) in spray mix .....	138
Review Questions for Chapter 9 .....	141

<b>Chapter 10. Using a Liquid Formulation to Prepare a Spray</b> .....	<b>145</b>
Introduction .....	145
Situation 1: Label rate stated as pounds of formulated product .....	146
Case A: Pints of product per 100 gallons of water .....	147
Case B: Pints of product per unit area of target site .....	152
Situation 2: Label rate stated as pounds of active ingredient .....	158
Case A: Pounds of active ingredient (AI) per 100 gallons of water .....	159
Case B: Pounds of active ingredient (AI) per acre .....	161
Situation 3: Label rate stated as percent active ingredient (%AI) in spray mix .....	163
Review Questions for Chapter 10 .....	167
<b>Chapter 11. Operations</b> .....	<b>171</b>
Pilot .....	171
Precautionary Actions .....	172
Application Methods .....	173
The Turnaround .....	173
Ferrying .....	174
Speed .....	175
Application Height .....	175
Obstructions .....	176
Power and telephone lines .....	176
Obstructions along side of field .....	176
Obstructions at end of field .....	176
Obstructions within a field .....	177
Deposit Pattern and Swath Spacing .....	177
Ground Crews .....	178
On-site Field Crew .....	178
Flag Crew .....	179
Mixing/Loading Crew .....	180
Equipment Servicing Crew .....	182
Steam Cleaning .....	183
Aircraft Crash Response .....	184
Review Questions for Chapter 11 .....	186
<b>Answers to Review Questions</b> .....	<b>193</b>



# Introduction

The first well-documented aerial application of a pesticide occurred near Troy, Ohio on August 3, 1921. The event became a matter of public record in the March 1922 issue of "The National Geographic Magazine" when C. R. Neillie and J. L. Houser described a Curtiss JN-6 (piloted by US Army Air Corps Lt. J. A. Macready) being used to apply lead arsenate (formulated as a dust) to a 6-acre stand of catalpa trees being grown for poles. The actual pesticide application was a two-man operation. The lead arsenate dust was released from Macready's aircraft by an externally-mounted, manually-cranked hopper, designed and built by Mr. E. Darmoy, who operated the device from the aircraft's observation seat during the flight. In 54 seconds of work time, the aerial team treated 4,815 trees with 175 pounds of pesticide formulation – thereby establishing a world's record for speed in applying insecticides to forested areas. Ever since, aircraft have played a role in the production of agricultural crops in the United States.

Today's agricultural aircraft are specifically designed to apply pesticide chemicals efficiently and safely. The term, "crop duster" – although widely used by the general public – is largely inappropriate. Very little aerially-applied pesticide is formulated as dust, mainly because spray is usually a more effective treatment and is considerably less prone to cause drift problems.

Modern aerial application of pesticide offers the advantages of timely site treatment, pesticide treatment of crop sites not readily accessible to ground equipment (for example, paddy rice), and lower fuel energy costs per treated acre on large tracts (for example, forest pest control efforts.)

Certain factors limit the utility of aerial application. These include:

- inclement weather,
- the presence of fixed obstacles,
- target site size and shape limitations,
- the intrinsic chemical properties of certain pesticidal active ingredients,
- ferry distance (*i.e.*, the distance between the application site and place where the aircraft is refilled and serviced), and
- the general public's misconceptions about aerial application of any pesticide.

Intrinsically, aircraft operation allows very little room for error -- in either pilot or machine. The same can be said for application of pesticide. Combining the two (flight and pesticide application) compounds risk - which, in turn, underscores the importance of a knowledgeable and competent pilot safely operating a properly configured aircraft. Hence this book.

The purpose of this manual is to provide pilots seeking licensure as aerial applicators with a reference book that enables successful preparation for the licensing exam that, in part, grants the privilege (and confers the responsibility) of using an aircraft to apply a pesticide.



# Chapter 1 - Regulations

## 14 CFR: Aeronautics and Space

Title 14 of the Code of Federal Regulations (14 CFR) contains the federal rules pertaining to aeronautics and space. The parts of 14 CFR most relevant to aerial applicators include:

- Part 61 -- Certification, Pilots and Flight Instructors
- Part 91 -- General Operating and Flight Rules
- Part 133 -- Rotocraft External-load Operations
- Part 137 -- Agricultural Aircraft Operations

The first three of these (14 CFR 61, 14 CFR 91, and 14 CFR 133) pertain to all pilots; the fourth, 14 CFR 137, is specific to aerial pesticide applicators. It is useful to obtain copies of Parts 61, 91 and 133 to better understand the provisions of 14 CFR 137. All four parts are available from:

Superintendent of Documents  
US Government Printing Ofc.  
Washington, D.C. 20402

The US Government Printing Office charges a fee for each publication it provides.

Because 14 CFR 137 is specific to aerial applicators, its text is reproduced in full on the following pages.

Keep in mind that federal regulations periodically change (sometimes unpredictably.) Aerial applicators can obtain an updated version of 14 CFR 137 by contacting the address given above and requesting a current copy of *14 CFR 137 and Revisions*. At the same time, it is possible to request being placed on the mailing list to receive future revisions.

# 14 CFR 137: Agricultural Aircraft Operations

## Subpart A - General

137.1 Applicability

137.3 Definition of terms

### 137.1 Applicability

- (a) This part prescribes rules governing--
  - (1) Agricultural aircraft operations within the United States, and
  - (2) The issue of commercial and private agricultural aircraft operator certificates for those operations.
- (b) In a public emergency a person conducting agricultural aircraft operations under this part may to the extent necessary deviate from the operating rules of this part for relief and welfare activities approved by an agency of the United States or of a state or local government.
- (c) Each person who, under the authority of this section, deviates from a rule of this part shall, within 10 days after the deviation send to the nearest FAA District Office a complete report of the aircraft operation involved, including a description of the operation and the reasons for it.

### 137.3 Definition of terms

For the purpose of this part--

"Agricultural aircraft operation" means the operation of an aircraft for the purpose of

- (1) dispensing any economic poison,
- (2) dispensing any other substance intended for plant nourishment, soil treatment, propagation of plant life, or pest control, or
- (3) engaging in dispensing activities directly affecting agriculture, horticulture, or forest preservation, but not including the dispensing of live insects.

"Economic poison" means

- (1) any substance or mixture of substances intended for preventing, destroying, repelling, mitigating any insects, rodents, nematodes, fungi, weeds, and other forms of plant or animal life or viruses, except viruses on or in living man or other animals, which the Secretary of Agriculture shall declare to be a pest, and
- (2) any substance or mixture of substances intended for use as a plant regulator, defoliant or desiccant.

## Subpart B - Certification Rule

137.11 Certificate required

137.15 Application for certificate

137.17 Amendment of certificate

137.19 Certification requirements

137.21 Duration of certificate

137.23 Carriage of narcotic drugs, marihuana and depressant or stimulant drugs or substances



### **137.11 Certificate required**

- (a) Except as provided in paragraphs (c) and (d) of this section, no person may conduct agricultural aircraft operations without, or in violation of, an agricultural aircraft operator certificate issued under this part.
- (b) Notwithstanding Part 133 of this chapter, an operator may, if he complies with this part, conduct agricultural aircraft operations with a rotocraft with external dispensing equipment in place without a rotocraft external-load operator certificate.
- (c) A federal, state, or local government conducting agricultural aircraft operations with public aircraft need not comply with this Subpart.
- (d) The holder of a rotocraft external-load operator certificate under part 133 of this chapter conducting an agricultural aircraft operation, involving only the dispensing of water on forest fires by rotocraft external-load means, need not comply with this subpart.

### **137.15 Application for certificate**

An application for an agricultural aircraft operator certificate is made on a form and in a manner prescribed by the Administrator, and filed with the FAA district office that has jurisdiction over the area in which the applicant's home base of operations is located.

### **137.17 Amendment of certificate**

- (a) An agricultural aircraft operator certificate may be amended --
  - (1) On the Administrator's own initiative, under section 609 of the Federal Aviation Act of 1958 (49 U.S.C. 1429) and Part 13 of this chapter; or
  - (2) Upon application by the holder of that certificate.
- (b) An application to amend an agricultural aircraft operator certificate is submitted on a form and in a manner prescribed by the Administrator. The applicant must file the application with the FAA district office having jurisdiction over the area in which the applicant's home base of operations is located at least 15 days before the date that it proposes the amendment become effective, unless a shorter filing period is approved by that office.
- (c) The district office grants a request to amend a certificate if it determines that safety in air commerce and the public interest so allow.
- (d) Within 30 days after receiving a refusal to amend, the holder may petition the Director, Flight Standards Service, to reconsider the refusal.

### **137.19 Certification requirements**

- (a) General. An applicant for a private agricultural aircraft operator certificate is entitled to that certificate if he shows that he meets the requirements of paragraphs (b), (d) and (e) of this section. An applicant for a commercial agricultural aircraft operator certificate is entitled to that certificate if he shows that he meets the requirements of paragraphs (c), (d), and (e) of this section. However, if an applicant applies for an agricultural aircraft operator certificate containing a prohibition against the dispensing of economic poisons, that applicant is not required to demonstrate the knowledge required in paragraphs (e)(1)(ii) through (iv) of this section.

- (b) Private operator-pilot. The applicant must hold a current U.S. private commercial, or airline transport pilot certificate and be properly rated for the aircraft to be used.
- (c) Commercial operator-pilots. The applicant must have available the services of at least one person who holds a current U.S. commercial or airline transport pilot certificate and who is properly rated for the aircraft to be used. The applicant himself may be the person available.
- (d) Aircraft. The applicant must have at least one certified and airworthy aircraft, equipped for agricultural operation
- (e) Knowledge and skill tests. The applicant must show, or have the person who is designated as the chief supervisor of agricultural aircraft operations for him show, that he has satisfactory knowledge and skill regarding agricultural aircraft operations, as described in paragraphs (e)(1) and (2) of this section.
  - (1) The test of knowledge consists of the following:
    - (i) Steps to be taken before starting operations, including survey of the area to be worked.
    - (ii) Safe handling of economic poisons and the proper disposal of used containers for those poisons.
    - (iii) The general effects of economic poisons and agricultural chemicals on plants, animals, and persons, with emphasis on those normally used in the areas of intended operations; and the precautions to be observed in using poisons and chemicals.
    - (iv) Primary symptoms of poisoning of persons from economic poisons, the appropriate emergency measures to be taken, and the location of poison control centers.
    - (v) Performance capabilities and operating limitations of the aircraft to be used.
    - (vi) Safe flight and applications procedures.
  - (2) The test of skill consists of the following maneuvers that must be shown in any of the aircraft specified in paragraph (d) of this section, and at that aircraft's maximum certificated take-off weight, or the maximum weight established for the special purpose load, whichever is greater:
    - (i) Short-field and soft-field takeoffs (airplanes and gyroplanes only).
    - (ii) Approaches to the working area.
    - (iii) Flare-outs.
    - (iv) Swath runs.
    - (v) Pullups and turnarounds.
    - (vi) Rapid deceleration (quick stops) in helicopters only.

### **137.21 Duration of certificate**

An agricultural aircraft operator certificate is effective until it is surrendered, suspended, or revoked. The holder of an agricultural aircraft operator certificate that is suspended or revoked shall return it to the Administrator.

### **137.23 Carriage of narcotic drugs, marijuana, and depressant or stimulant drugs or substances**

If the holder of a certificate issued under this part permits any aircraft owned or leased by that holder to be engaged in any operation that the certificate holder knows to be in violation of §91.12(a) of this chapter, that operation is a basis for suspending or revoking the certificate.

## **Subpart C - Operating Rules**

- 137.29 General
- 137.31 Aircraft requirements
- 137.33 Carrying certificate
- 137.35 Limitations on private agricultural aircraft operator
- 137.37 Manner of dispensing
- 137.39 Economic poison dispensing
- 137.41 Personnel
- 137.43 Airport traffic areas and control zones
- 137.45 Nonobservance of airport traffic pattern
- 137.47 Operation without position lights
- 137.49 Operations over other than congested areas
- 137.51 Operations over congested areas general
- 137.53 Operation over congested areas: pilots and aircraft
- 137.55 Business name: commercial agricultural aircraft operator
- 137.57 Availability of certificate
- 137.59 Inspection authority

### **137.29 General**

- (a) Except as provided in paragraphs (d) and (e) of this section, this Subpart prescribes rules that apply to persons and aircraft used in agricultural aircraft operations conducted under this part.
- (b) [Reserved]
- (c) The holder of an agricultural aircraft operators certificate may deviate from the provisions of Part 91 of this chapter without a certificate of waiver, as authorized in this Subpart for dispensing operations related to agriculture horticulture, or forest preservation in accordance with the operating rules of this Subpart.
- (d) Sections 137.31 through 137.35, 137.41, and 137.53 through 137.59 do not apply to persons and aircraft used in agricultural aircraft operations conducted with public aircraft.
- (e) Sections 137.31 through 137.35, 137.39, 137.41, 137.51 through 137.59 and Subpart D do not apply to persons and rotorcraft used in agricultural aircraft operations conducted by a person holding a certificate under Part 133 of this chapter and involving only the dispensing of water on forest fires by rotocraft external-load means. However, the operation shall be conducted in accordance with --
  - (i) The rules of Part 133 of this chapter governing rotorcraft external-load operations; and
  - (ii) The operating rules of this Subpart contained in §137.29, 137.37, and 137.43 through 137.49.

### **137.31 Aircraft requirements**

No person may operate an aircraft unless that aircraft --

- (a) Meets the requirements of §137.19(d); and
- (b) Is equipped with a suitable and properly installed shoulder harness for use by each pilot.

### **137.33 Carrying of certificate**

- (a) No person may operate an aircraft unless a facsimile of the agricultural aircraft operator certificate, under which the operation is conducted, is carried on that aircraft. The facsimile shall be presented for inspection upon the request of the Administrator or any federal, state, or local law enforcement officer.
- (b) Notwithstanding Part 91 of this chapter, the registration and airworthiness certificates issued for the aircraft need not be carried in the aircraft. However, when those certificates are not carried in the aircraft they shall be kept available for inspection at the base from which the dispensing operation is conducted.

### **137.35 Limitations on private agricultural aircraft operator**

No person may conduct an agricultural aircraft operation under the authority of a private agricultural aircraft operator certificate --

- (a) For compensation or hire;
- (b) Over a congested area; or
- (c) Over any property unless he is the owner or lessee of the property or has ownership or other property interest in the crop located on that property.

### **137.37 Manner of dispensing**

No persons may dispense, or cause to be dispensed, from an aircraft, any material or substance in a manner that creates a hazard to persons or property on the surface.

### **137.39 Economic poison dispensing**

- (a) Except as provided in paragraph (b) of this section, no person may dispense or cause to be dispensed from an aircraft, any economic poison that is registered with the U.S. Department of Agriculture under the Federal Insecticide, Fungicide, and Rodenticide Act (7 U.S.C.135-135k) --
  - (1) For a use other than that for which it is registered;
  - (2) Contrary to any safety instruction or use limitations on its label; or
  - (3) In violation of any law or regulation of the United States.
- (b) This section does not apply to any person dispensing economic poisons for experimental purposes under --
  - (1) The supervision of a federal or state agency authorized by law to conduct research in the field of economic poisons; or
  - (2) A permit from the U.S. Department of Agriculture issued pursuant to the Federal Insecticide, Fungicide, and Rodenticide Act (7 U.S.C. 135-135k).

### **137.41 Personnel**

- (a) Information. The holder of an agricultural aircraft operator certificate shall insure that each person used in the holder's agricultural aircraft operation is informed of that person's duties and responsibilities for the operation.
- (b) Supervisors. No person may supervise an agricultural aircraft operation unless he has met the knowledge and skill requirements of § 137.19(e).
- (c) Pilot in command. No person may act as pilot in command of an aircraft unless he holds a pilot certificate and rating prescribed by § 137.19(b) or (c), as appropriate to the type of operation conducted. In addition, he must demonstrate to the holder of the Agricultural Aircraft Operator Certificate conducting the operation that he has met the knowledge and skill requirements of § 137.19(e). If the holder of that certificate has designated a person under § 137.19(e) to supervise his agricultural aircraft operations the demonstration must be made to the person so designated. However, a demonstration of the knowledge and skill requirement is not necessary for any pilot in command who --
  - (1) Is, at the time of the filing of an application by an agricultural aircraft operator, working as a pilot in command for that operator; and
  - (2) Has a record of operation under that applicant that does not disclose any question regarding the safety of his flight operations or his competence in dispensing agricultural materials or chemicals.

### **137.43 Airport traffic areas and control zones**

- (a) Except for flights to and from a dispensing area, no person may operate an aircraft within an airport traffic area, or within a control zone having an operative control tower, unless authorization for that operation has been obtained from the control tower concerned.
- (b) No person may operate an aircraft in weather conditions below VFR minimums within a control zone not having an operative control tower unless authorization for that operation has been obtained from the appropriate ATC facility.
- (c) Notwithstanding § 91.107(e) of this chapter, an aircraft may be operated in a control zone under special VFR weather minimums without meeting the requirements prescribed therein.

### **137.45 Nonobservance of airport traffic pattern**

Notwithstanding Part 91 of this chapter, the pilot in command of an aircraft may deviate from an airport traffic pattern when authorized by the control tower concerned. At an airport without a functioning control tower, the pilot in command may deviate from the traffic pattern if --

- (a) Prior coordination is made with the airport management concerned;
- (b) Deviations are limited to the agricultural aircraft operation;
- (c) Except in an emergency, landing and takeoffs are not made on ramps, taxiways, or other areas of the airport not intended for such use; and
- (d) The aircraft at all times remains clear of, and gives way to, aircraft conforming to the traffic pattern for the airport.

### **137.47 Operation without position lights**

Notwithstanding Part 91 of this chapter, an aircraft may be operated without position lights if prominent unlighted objects are visible for at least 1 mile and takeoffs and landings at --

- (a) Airports with a functioning control tower are made only as authorized by the control tower operator, and
- (b) Other airports are made only with the permission of the airport management and no other aircraft operations requiring position lights are in progress at that airport.

### **137.49 Operations over other than congested areas**

Notwithstanding Part 91 of this chapter, during the actual dispensing operation, including approaches, departures, and turnarounds reasonably necessary for the operation, an aircraft may be operated over other than congested areas below 500 feet above the surface and closer than 500 feet to persons, vessels, vehicles, and structures. If the operations are conducted without creating a hazard to persons or property on the surface.

### **137.51 Operation over congested areas: general**

- (a) Notwithstanding Part 91 of this chapter, an aircraft may be operated over a congested area at altitudes required for the proper accomplishment of the agricultural aircraft operation if the operation is conducted --
  - (1) With the maximum safety to persons and property on the surface, consistent with the operation; and
  - (2) In accordance with the requirements of paragraph (b) of this section.
- (b) No person may operate an aircraft over a congested area except in accordance with the requirements of this paragraph.
  - (1) Prior written approval must be obtained from the appropriate official or governing body of the political subdivision over which the operations are conducted.
  - (2) Notice of the intended operation must be given to the public by some effective means, such as daily newspapers, radio, television, or door-to-door notice.
  - (3) A plan for each complete operation must be submitted to, and approved by appropriate personnel of the Federal Aviation Administration District Office having jurisdiction over the area where the operation is to be conducted. The plan must include consideration of obstructions to flight; the emergency landing capabilities of the aircraft to be used; and any necessary coordination with air traffic control.
  - (4) Single engine aircraft must be operated as follows;
    - (i) Except for helicopters, no person may take off a loaded aircraft, or make a turnaround over a congested area.
    - (ii) No person may operate an aircraft over a congested area below the altitudes prescribed in Part 91 of this chapter except during the actual dispensing operation, including the approaches and departures necessary for that operation.
    - (iii) No person may operate an aircraft over a congested area during the actual dispensing operation, including the approaches and departures for that operation, unless it is operated in a pattern and at such an altitude that the aircraft can land, in an emergency, without endangering person or property on the surface.

(5) Multi-engine aircraft must be operated as follows:

- (i) No person may take off a multi-engine airplane over a congested area except under conditions that will allow the airplane to be brought to a safe stop within the effective length of the runway from any point on takeoff up to the time of attaining, with all engines operating at normal takeoff power, 105 percent of the minimum control speed with the critical engine inoperative in the takeoff configuration or 115 percent of the power-off stall speed in the takeoff configuration, whichever is greater, as shown by the accelerate stop distance data. In applying this requirement, takeoff data is based upon still-air conditions and no correction is made for any uphill gradient of 1 percent or less when the percentage is measured as the difference between elevation at the end points of the runway divided by the total length. For uphill gradients greater than 1 percent, the effective takeoff length of the runway is reduced 20 percent for each 1-percent grade.
- (ii) No person may operate a multi-engine airplane at a weight greater than the weight that, with the critical engine inoperative, would permit a rate of climb of at least 50 feet per minute at an altitude of at least 1,000 feet above the elevation of the highest ground or obstruction within the area to be worked or at an altitude of 5,000 feet, whichever is higher. For the purposes of this subdivision it is assumed that the propeller of the inoperative engine is in the minimum drag position, that the wing flaps and landing gear are in the most favorable positions, and that the remaining engine or engines are operating at the maximum continuous power available.
- (iii) No person may operate any multi-engine aircraft over a congested area below the altitudes prescribed in Part 91 of this chapter except during the actual dispensing operation, including the approaches, departures, and turnarounds necessary for that operation.

**137.53 Operations over congested areas: pilots and aircraft**

- (a) General. No person may operate an aircraft over a congested area except in accordance with the pilot and aircraft rules of this section.
- (b) Pilots. Each pilot in command must have at least --
  - (1) 25 hours of pilot-in-command flight time in the make and basic model of the aircraft, at least 10 hours of which must have been acquired within the preceding 12 calendar months; and
  - (2) 100 hours of flight experience as pilot-in-command in dispensing agricultural materials or chemicals .
- (c) Aircraft.
  - (1) Each aircraft must --
    - (i) If it is an aircraft not specified in paragraph (c)(1 xii) of this section, have had within the preceding 100 hours of time in service a 100-hour or annual inspection by a person authorized by Part 65 or 145 of this chapter, or have been inspected under a progressive inspection system, and

- (ii) If it is a large or turbine-powered multi-engine civil airplane of U.S. registry, have been inspected in accordance with the applicable inspection program requirements of S 91.217 of this chapter.
- (2) If other than a helicopter, it must be equipped with a device capable of jettisoning at least one-half of the aircraft's maximum authorized load of agricultural material within 45 seconds. If the aircraft is equipped with a device for releasing the tank or hopper as a unit, there must be a means to prevent inadvertent release by the pilot or other crew member.

**137.55 Business name: commercial agricultural aircraft operator**

No person may operate under a business name that is not shown on his commercial agricultural aircraft operator certificate.

**137.57 Availability of certificate**

Each holder of an agricultural aircraft operator certificate shall keep that certificate at his home base of operations and shall present it for inspection on the request of the Administrator or any Federal, State, or local law enforcement officer.

**137.59 Inspection authority**

Each holder of an agricultural aircraft operator certificate shall allow the Administrator at any time and place to make inspections, including on-the-job inspections, to determine compliance with applicable regulations and his agricultural aircraft operator certificate .

## **Subpart D · Records and Reports**

- 137.71 Records: commercial agricultural aircraft operator
- 137.75 Change of address
- 137.77 Termination of operations

**137.71 Records: commercial agricultural aircraft operator**

- (a) Each holder of a commercial agricultural aircraft operator certificate shall maintain and keep current, at the home base of operations designated in his application, the following records:
  - (1) The name and address of each person for whom agricultural aircraft services were provided;
  - (2) The date of the service;
  - (3) The name and quantity of the material dispensed for each operation conducted; and
  - (4) The name, address, and certificate number of each pilot used in agricultural aircraft operations and the date that pilot met the knowledge and skill requirements of § 137.19(e).
- (b) The records required by this section must be kept at least 12 months and made available for inspection by the Administrator upon request.



### **137.75 Change of address**

Each holder of an agricultural aircraft operator certificate shall notify the FAA in writing in advance of any change in the address of his home base of operations.

### **137.77 Termination of operations**

Whenever a person holding an agricultural aircraft operator certificate ceases operations under this part, he shall surrender that certificate to the FAA District Office last having jurisdiction over his operation.

## **Other Federal Rules**

In addition to FAA regulations, aerial applicators should be aware of certain other federal rules governing the behavior of pesticide applicators. Most notably, these include:

### **Title 40 -- Protection of Environment, Subchapter E -- Pesticide Programs, Parts 162-172, and Part 180.**

Of particular importance are:

- 40 CFR 162 -- pesticide product registration provisions,
- 40 CFR 165 -- procedures for disposal and storage for pesticides and pesticide containers, and,
- 40 CFR 170 -- the **Worker Protection Standard** (pertains to aerial applicators who contract to spray a pesticide on agricultural plants being produced on farms, nurseries, or forests.)

Copies of these regulations can be purchased at Regional Government Bookstores or from:

Superintendent of Documents  
Government Printing Office  
Washington, D.C. 20402

## **State Laws and Rules**

Every state always has the option to write laws and rules that are *more stringent* than federal laws and regulations. Many states do so. Whenever this occurs, *state law governs the issue*. For this reason, a working knowledge of state law and rules is 'essential equipment' for every aerial applicator.

Copies of state-specific laws and rules governing pesticide use and applicator licensure (including aerial application of a pesticide) can usually be obtained (often without cost) by contacting the state regulatory agency (typically, the state's Department of Agriculture) that administers the state's pesticide applicator certification program.

## The Label as Law

Finally, the *instructions found on pesticide product labels carry the force of law* -- hence the saying, "The label is the law." For example, certain pesticide labels expressly prohibit aerial application of that particular pesticide product. Application of the product via aircraft could result in the aerial applicator being summoned to respond to charges in state (or federal) court. Courts have consistently ruled that pesticide label language takes precedence and must be fully obeyed.

Further, manufacturers of pesticide products often find it necessary to alter the label instructions that accompany their pesticide products. Typically, a change in label language is a consequence of some new provision in federal (or state) rule. Regardless of the reason behind a label language change, its practical importance to applicators includes:

- Without exception, be certain to read the entire pesticide label of every pesticide product prior to using it. **Be especially on the lookout for wording changes in:**
  - *directions for use,*
  - *application sites (crops, buffer zone requirements, etc.) ,*
  - *application rates,*
  - *handling precautions,*
  - *personal protective equipment requirements,*
  - *storage and disposal statements, and*
  - *environmental protection measures.*
  
- Avoid the complacency that often accompanies familiarity. Just because you've "...used Product X for years..." doesn't mean you have no need to read its label. Many longstanding pesticide products now have substantially revised labels.

**Proper application begins by  
reading the pesticide label.**

- Re-registration (a legal process being conducted by the federal government) of all pesticide products is currently ongoing – and can be expected to continue for the next few years. One of the likely consequences of this process is that pesticide users will probably encounter new label language on many of the pesticide products that they've known about and used for years. The best way to be aware of any such change is to regularly and carefully read the pesticide product label.

# Review Questions for Chapter 1

(Answers: page 193)

01. Strictly speaking, whenever a part of 14 CFR 137 mentions "agricultural aircraft operation", aerial dispensing of a pesticide (*i.e.*, an insecticide, herbicide, fungicide, etc.) is the activity actually meant.

**True**            **False**

{text: Ch 1; p 4}

Comment: \_\_\_\_\_  
\_\_\_\_\_

02. To obtain a current copy of all provisions of 14 CFR 137 that affect aerial applicators, one should contact the nearest FAA regional office.

**True**            **False**

{text: Ch 1; p 3}

Comment: \_\_\_\_\_  
\_\_\_\_\_

03. 14 CFR 137 does not require rotocraft pilots seeking aerial applicator certificates to demonstrate proficiency in soft-field takeoffs and landings.

**True**            **False**

{text: Ch 1; p 6}

Comment: \_\_\_\_\_  
\_\_\_\_\_

04. Under 14 CFR 137, an agricultural aircraft operator certificate remains valid and effective for no more than 5 years after date of issue.

**True**            **False**

{text: Ch 1; p 6}

Comment: \_\_\_\_\_  
\_\_\_\_\_

# Review Questions for Chapter 1

(Answers: page 193)

05. According to 14 CFR 137, each agricultural aircraft in service must contain facsimile copies of the agricultural aircraft operator certificate, the aircraft registration certificate, and the craft's airworthiness certificate.

**True**

**False**

{text: Ch 1; p 8}

Comment: \_\_\_\_\_  
\_\_\_\_\_

06. 14 CFR 137 contains no specific provisions governing actual agricultural chemical dispensing *per se*; this is because (a) the principal purpose of 14 CFR 137 is to specify requirements of aerial applicator certification within the framework of all other FAA regulations; and (b) actual agricultural chemical dispensing is governed exclusively by label language.

**True**

**False**

{text: Ch 1; p 8}

Comment: \_\_\_\_\_  
\_\_\_\_\_

07. For so long as he or she abides by all pertinent provisions of 14 CFR 137, an agricultural aircraft pilot may deviate from an air traffic pattern legitimately established by airport management.

**True**

**False**

{text: Ch 1; p 9}

Comment: \_\_\_\_\_  
\_\_\_\_\_

# Review Questions for Chapter 1

(Answers: page 193)

08. The provisions of 14 CFR 137 establish a minimum setback distance (500 feet) as a fixed buffer zone between aerial application work and nearby person, vessel, vehicle, or structure.

**True**

**False**

{text: Ch 1; p 10}

Comment: \_\_\_\_\_

\_\_\_\_\_

09. 14 CFR 137 contains specific rules governing pesticide storage and disposal of pesticide containers.

**True**

**False**

{text: Ch 1; p 13}

Comment: \_\_\_\_\_

\_\_\_\_\_

10. Any aerial applicator who contracts to apply an agricultural chemical on a commercial establishment of agricultural plants is responsible for ensuring the notification provisions of the Worker Protection Standard (WPS) have been implemented at the target site prior to the dispensing of the agricultural chemical.

**True**

**False**

{text: Ch 1; p 13}

Comment: \_\_\_\_\_

\_\_\_\_\_

## Review Questions for Chapter 1

(Answers: page 193)

11. Whenever both state and federal law supply specific provisions governing aerial applicators, federal law prevails.

**True**

**False**

{text: Ch 1; p 13}

Comment: \_\_\_\_\_

\_\_\_\_\_

12. The label language of longstanding pesticide products is unlikely to ever undergo change.

**True**

**False**

{text: Ch 1; p 14}

Comment: \_\_\_\_\_

\_\_\_\_\_

## Chapter 2 - Pesticides and Human Health

### Introduction

Based on derivation, the active ingredients found in pesticides (insecticides, fungicides, herbicides, nematicides, etc.) can be grouped into three major categories:

- *inorganic* compounds,
- *synthetic organic* compounds, and
- *biologically-derived* compounds.

Inorganic pesticides are mineral substances lacking carbon (e.g., sulfur, cryolite, etc.) Synthetic organic pesticides are man-made compounds formed by chemically modifying petroleum distillates or other carbon-based substances (such as coal tar.) Biologically-derived pesticides are chemical substances obtained from plants, animals or fungi.

From a toxicological viewpoint, no single group is more or less benign (or "safe") than another. The vast majority of the compounds in all three groups function via poisoning; specific toxicity varies widely throughout the groups. For every pesticide, regardless of its origin, the fundamental act of every aerial applicator (and all who handle pesticides for him or her) must be to carefully and completely read and obey the pesticide product's label before using that particular pesticide (not doing so violates state and federal law.)

### Exposure

In humans, adverse exposure to chemical substances occurs by **absorption** – the taking up of a substance by physical/chemical forces. Chemical substances (wet or dry) enter the body *through the membranous covering of the eye* (ocular absorption), *through the tissues of the lungs and associated airways* (respiratory absorption), *through the linings of the mouth, stomach and intestine* (oral and gastro-intestinal tract absorption), or *through the skin* (dermal absorption). For pesticide handlers engaged in aerial application activities, dermal absorption is the most likely route of adverse exposure to a pesticidal substance.

Human skin is not created equal over the entire body (lips have different skin than heels.) Because of differences in skin texture and structure, for any given chemical, a person's skin is differentially absorptive. Put plainly, *the skin covering some portions of the human body more readily absorbs pesticide chemicals.* This concept is illustrated below (Table 1.) The data are from pesticide exposure experiments conducted on human volunteers not wearing personal protective equipment (PPE).

**Table 1. Absorptive Differences of Human Skin**

<b>Body Part</b>	<b>pesticide absorption (%)</b>
Scalp	32.1
Ear Canal	46.5
Forehead	36.3
Forearm	8.6
Palm of Hand	11.8
Abdomen	18.4
Scrotum	100.0
Ball of Foot	13.5

Data such as these form the basis for pesticide label statements requiring pesticide handlers to pay careful attention to personal hygiene and wear specific articles of PPE (gloves, aprons, boots, etc.) Wearing personal protective equipment helps deter absorption of potentially harmful chemicals. Notice that certain parts of the human body (scrotum, ear canal, forehead, and scalp) have especially absorptive skin.

### **Dosage**

Regardless of its derivation or other classification scheme, the effect of any chemical compound (alcohol, aspirin, table salt, parathion, diazinon, paraquat, chocolate, etc.) depends on two factors:

- the *amount of chemical* absorbed;
- the *size of the organism* receiving the chemical.

When these two factors are considered **together**, their measurement (as a single thing) is termed “dosage.” Dosages of pesticide chemicals are measured in a standardized format that uses metric weight. Where:

- the amount of chemical is measured in milligrams (*mg.*),
- the size of the recipient organism is measured in kilograms (*kg.*)

The resulting ratio is *parts per million* (1 milligram is 1/1,000,000th of a kilogram.) Thus, dosage describes the weight of chemical actually present in (or on) an exposed (or treated) organism, and while doing so, takes into account the size of the organism itself.

Ingestion of a single grain of common table salt will injure an ant, but not a human. The chemical composition of the salt is the same in both cases, the difference is dosage. Because the ant weighs much less than the human, less table salt is required to poison the ant. (At some amount of table



salt ingestion -- approximately 2 tablespoonfuls -- the human will be injured, too.) Dosage can be thought of as science's way of quantifying the adage, "Too much of anything is harmful."

## Toxicity

Equal amounts of different chemical substances typically exhibit entirely different capabilities to cause injury. (The magnitude of injury sustained by a healthy human who swallows two tablespoonfuls of sugar is predictably different from that of the same person swallowing two tablespoonfuls of table salt.) Here, although the amounts being consumed are the same, the chemical substances themselves are very different. This "inherent capability" of a chemical substance to cause injury (act as a poison) is referred to as *toxicity*. In the practical world, toxicity would remain a virtually useless concept if no yardstick were available to measure it.

*Dosage is a "yardstick" that helps to assess and classify pesticide toxicity.*

Every registered pesticide product has a signal word (e.g., **Danger, Warning, Caution**) prominently displayed on its label. The main reason for displaying a signal word is to readily indicate the pesticide product's toxicity category. Each toxicity category is defined by a range of dosages. How dosage helps measurement and characterization of pesticide toxicity is briefly (and incompletely) portrayed in Table 2.

**Table 2. Toxicity Categories of Pesticide Products**

Oral LD <sub>50</sub> (lethal dosage if swallowed)	Toxicity Category	Hazard Characterization by US-EPA
50 ppm or less	I	Highly Hazardous
51 ppm to 500 ppm	II	Moderately Hazardous
501 ppm to 5000 ppm	III	Slightly Hazardous
more than 5000 ppm	IV	Relatively Nonhazardous

Manufacturers of pesticide products conduct a vast battery of tests on each candidate pesticide chemical. These tests evaluate the effect of dosage on groups of test organisms. The eventual result is a determination of the minimum dosage likely to kill 50% of the organisms in a test group. This dosage value is called the LD<sub>50</sub> – (Lethal Dosage for 50% of the test population.)

A very low LD<sub>50</sub> value indicates that treatments involving very small dosages (50 ppm or less) of that chemical can be reasonably expected to cause a 50% death rate in a group of treated subjects. All such chemical substances are considered to be strongly poisonous (i.e., highly toxic) – that is to say, their "inherent capability" to act as poisons is very pronounced.

Conversely, a dosage-response test which yields a high LD<sub>50</sub> value indicates that a relative large dosage (more than 500 ppm) of the tested chemical must be administered in order to expect a 50% death rate in a test group of organisms. Thus, chemical substances that have high LD<sub>50</sub> values are considered to have weak “inherent capability” to act as a poison. All such chemical substances are classed as having slight (*i.e.*, low) toxicities.

Pesticide manufacturers use dosage-response testing to assess every avenue of potential human exposure (oral, ocular, inhalation, dermal, etc.) to a pesticide product. The signal word that appears on the pesticide product’s label is a practical summary of that product’s dosage-response testing results. Aerial applicators and all pesticide handlers working under an aerial applicator’s direct supervision must be able to correctly interpret and act upon the signal word displayed on the label of the pesticide product currently being handled.

### Signs and Symptoms

The **signs** (*visible indications of poisoning that another can SEE in a victim*) and **symptoms** (*invisible evidence of poisoning that only the victim can FEEL*) differ among various pesticides, but all are dosage (or dose-interval) dependent. Hence the common saying, “The dose makes the poison” (which, strictly speaking, is a slight misstatement.)

Typically, the chemical substance itself influences the time required for first appearance of signs or symptoms of overexposure. Thus, signs or symptoms of acute (short term) pesticide poisoning often commence soon after overexposure to a direct cholinesterase inhibitor (such as *carbofuran*.) Relatedly, indications of acute poisoning are apt to be unrecognizable for several hours when the exposure is to a delayed cholinesterase inhibitor (such as *phorate*.)

Signs or symptoms of poisoning that first appear more than 24 hours after the termination of exposure might be an instance of cumulative poisoning (an overexposure response resulting from multiple small exposures – incurred over a protracted period of time.) For example, *lead* (Pb) is a cumulative poison.

Commonly-reported signs and symptoms of pesticide poisoning, more-or-less in their order of progression, that aerial applicators and their ground crews should be aware of include:

- headache
- visual disturbance (blurred vision)
- pupillary abnormalities (primarily pinpoint pupils; rarely dilated pupils)
- increased secretion (sweating, salivation, tearing and respiratory secretions)
- sensation of “tightness” or constriction in chest
- nausea or vomiting
- pulmonary edema (lungs beginning to fill with fluid)
- changes in heart rate
- mental confusion
- respiratory paralysis
- convulsions and/or coma
- death.

## **Cholinesterase Tests**

Aerial applicators and their pesticide handlers who expect to regularly work with large quantities of organophosphate pesticide may wish to establish a regular cholinesterase testing program with a physician. Typically, such a program consists of a initial cholinesterase test to determine the individual's "base line" cholinesterase level (measured during the off-season – when exposure to organophosphate pesticide is very low or nonexistent.)

When the likelihood of exposure to this type of pesticide is higher (e.g., during spraying season), the tests are repeated and the results compared with the base line level. Program participants can monitor changes in cholinesterase level during seasons when potential for exposure to such pesticides is heightened. If an individual's cholinesterase level become too depressed, the physician may advise that person to reduce (or stop) handling organophosphate pesticides until his/her cholinesterase level sufficiently recovers.

## **First Aid for Pesticide Overexposure Victims**

First aid is the initial effort to help a victim while medically-trained help is on the way. As part of their normal workplace preparedness, all aerial applicators and their pesticide handlers should have a working knowledge of basic first aid practices for pesticide poisoning victims.

Whenever others are also present to help, the first step in any poisoning emergency is to *contact an ambulance service, a poison control center, or a medical doctor* and clearly explain the situation. The notable exception is when you are alone with the injured person. Then you must first see that he (or she) is breathing and out of further exposure to the pesticide before leaving to make a phone call. Whenever helping an injured person, take care not to become contaminated with the pesticide yourself. Always save the pesticide and the label for the medical authorities.

## **Pesticide on the Skin**

- Act promptly (the sooner the skin is rinsed, the better the result.)
- Remove all pesticide-contaminated clothing and thoroughly (15-20 minutes) rinse the victim's skin with plenty of clean water.
- Towel the rinsed area and loosely cover the victim (clean sheet or light blanket.)
- Contact medical authorities.

***WARNING: Keep the pesticide off of you while helping the victim.***

## **Chemical Burn (Blistered Skin)**

- Act promptly.
- Remove pesticide-contaminated clothing and thoroughly (15-20 minutes) rinse the victim's skin with plenty of clean water. *Do not towel dry.*
- Loosely cover the cleaned area with clean, soft cloth.
- **Do not** apply any ointment, grease, spray or other substance to chemically-burned skin.
- Contact medical authorities.

## **Pesticide in the Eye**

- Act promptly.
- Tilt the victim's head and torso to the side. Keep the victim's eyelids open.
- Rinse both eyes simultaneously by flowing a gentle stream of clean water into the outer corner of the uppermost eye. Insure the stream of water steadily flows across both eyes.
- Continue the eye rinse for 15-20 minutes (a long time).
- If the victim wears contact lens, remove the contact lenses after the first 5 minutes of rinsing – then continuing rinsing the eyes.
- **Do not** use drugs in the eye rinse water. (They may increase the injury.)
- Contact medical authorities.

## **Inhaled Pesticide (Dusts, Aerosols, Vapors, Gases)**

- If victim is in an enclosed area, put on a respirator before attempting rescue.
- Carry or drag victim (do not let him walk) to fresh air.
- Loosen tight clothing.
- Give artificial respiration (mouth-to-mouth resuscitation) if victim's breathing has stopped.

- If victim is convulsing, protect him from striking his head. Pull the chin forward to prevent the tongue from blocking the air passage.
- Prevent chilling (cover victim with light blanket.)
- Contact medical authorities.

## **Swallowed Pesticide**

- Before anything else, *find out exactly what pesticide has been swallowed.*
- Call a poison control center or medical doctor immediately for treatment advice.
- Do not give the victim anything to eat or drink without first obtaining clear permission from the poison control center or medical doctor.

***WARNING: Never try to give anything by mouth to an unconscious person.***

## **Traumatic Shock**

Every aerial applicator should recognize that a victim of pesticide overexposure may go into shock. If shock is untreated or ignored, the victim can die from shock -- even if the poisoning is non-life-threatening.

### **Signs of Shock**

Skin is pale, moist, cold and clammy. Eyes are vacant and lackluster with dilated pupils. Breathing is shallow and irregular. Pulse is weak, rapid and irregular. Victim may faint.

### **First Aid for Shock**

Unless he/she is vomiting, lie victim flat on his back. Position the feet and legs higher than the head (feet elevated). ) Keep victim warm enough to prevent shivering.

If victim is conscious and has not swallowed a pesticide, give small amounts of water to drink. Give as often as victim will accept it. Keep victim quiet and reassure him or her often.

***WARNING: Never try to give anything by mouth to an unconscious person.***

## First Aid Equipment

A simple, readily available, first-aid kit is important in a pesticide emergency. Every aerial applicator should have one. It should be a sturdy container and have a tight fitting, latched, cover. It should be clearly marked and readily accessible to those most likely to need it.

### Contents:

- Small plastic bottle of soap solution.
- Shaped plastic airway for mouth-to-mouth resuscitation.
- Simple "band aids," bandages, and tape.
- Roll (or package) of paper towels.
- Lightweight blanket.
- Pencil and notepad containing:
  - *name and phone number* of a **Poison Control Center**
  - *name and phone number* of a nearby **ambulance service**
  - *name and phone number* of a nearby **medical doctor**

Inform the doctor of your intention to contact him/her in the event of an emergency involving pesticide overexposure. Provide him/her with a list of the pesticide products that you expect to use during the spray season. These acts are often of great benefit – helping the doctor have up-to-date information on treating overexposure to specific pesticides usually promotes a more rapid response to any emergency that subsequently arises.

Remember: In any instance of a pesticide-related injury, always provide the emergency health care provider (ambulance attendant, physician etc.) with *a copy of the pesticide product label*.

## Medical Antidotes

Antidotal drugs (atropine sulfate, protopam chloride, dimercaperol, sodium thiosulfate, monocetin, etc.) should be prescribed and administered **only by a qualified physician**. Their misuse (improper dosage or wrong choice of treatment) can be deadly.

There are no drugs to prevent poisoning. That's a simple truth. At best, one can only attempt to minimize the likelihood of a poisoning occurrence. To do so, always fully read and follow the pesticide label's directions, strive to continuously maintain a safety-conscious work environment, and ensure each pilot, pesticide handler and ground crew member working under the certified aerial applicator's supervision learns (and has ample opportunity to practice) first-aid responses to pesticide-related injuries.

## Review Questions for Chapter 2

(Answers: page 193)

01. Pesticides made from petroleum-derived products (synthetic organic compounds) are intrinsically more toxic than pesticides derived from plants, animals, or fungi.

**True**

**False**

{text: Ch 2; p 19}

Comment: \_\_\_\_\_  
\_\_\_\_\_

02. For pesticide handlers engaged in aerial application work, dermal absorption is the most likely route of adverse exposure to a pesticidal substance.

**True**

**False**

{text: Ch 2; p 19}

Comment: \_\_\_\_\_  
\_\_\_\_\_

03. The absorptiveness of human skin is the same all over the human body.

**True**

**False**

{text: Ch 2; p 19}

Comment: \_\_\_\_\_  
\_\_\_\_\_

04. The potential for injury from a chemical is influenced by the amount absorbed by the victim.

**True**

**False**

{text: Ch 2; p 21}

Comment: \_\_\_\_\_  
\_\_\_\_\_

## Review Questions for Chapter 2

(Answers: page 193)

05. In a practical sense, the term “toxicity” refers to chemical’s inherent capability to cause an injury.

**True**

**False**

{text: Ch 2; p 21}

Comment: \_\_\_\_\_  
\_\_\_\_\_

06. In simple, the concept of “dosage” is used to measure and characterize a pesticide’s toxicity.

**True**

**False**

{text: Ch 2; p 21}

Comment: \_\_\_\_\_  
\_\_\_\_\_

07. A low LD<sub>50</sub> value is indicative of low toxicity.

**True**

**False**

{text: Ch 2; p 21}

Comment: \_\_\_\_\_  
\_\_\_\_\_

08. The signal word displayed on a pesticide label’s frontpiece is a practical summary of that product’s toxicity.

**True**

**False**

{text: Ch 2; p 21}

Comment: \_\_\_\_\_  
\_\_\_\_\_



## Review Questions for Chapter 2

(Answers: page 193)

09. For most cases of handler exposure to a pesticide product, the onset of any specific sign or symptom of pesticide poisoning is independent of dosage.

**True**

**False**

{text: Ch 2; p 22}

Comment: \_\_\_\_\_  
\_\_\_\_\_

10. The term “cumulative poisoning” refers to an overexposure response resulting from multiple small exposures to a pesticide incurred over a lengthy period of time.

**True**

**False**

{text: Ch 2; p 22}

Comment: \_\_\_\_\_  
\_\_\_\_\_

11. Experiencing a feeling of “tightness” or “constriction” in the chest is a common early sign of overexposure to a pesticide.

**True**

**False**

{text: Ch 2; p 22}

Comment: \_\_\_\_\_  
\_\_\_\_\_

12. In the context of pesticide poisoning, the terms “sign” and “symptom” essentially mean the same thing and should be used interchangeably.

**True**

**False**

{text: Ch 2; p 22}

Comment: \_\_\_\_\_  
\_\_\_\_\_

## Review Questions for Chapter 2

(Answers: page 193)

13. Pesticide handlers who work as full-time employees under the supervision of an aerial applicator must participate in a regular cholinesterase monitoring program.

**True**

**False**

{text: Ch 2; p 23}

Comment: \_\_\_\_\_  
\_\_\_\_\_

14. A cholinesterase monitoring program is intended to help provide prompt detection of a person's overexposure to organophosphate pesticides.

**True**

**False**

{text: Ch 2; p 23}

Comment: \_\_\_\_\_  
\_\_\_\_\_

15. In most cases, the best first-aid response for a chemical burn is to immediately try to relieve pain and suffering by applying a soothing burn treatment spray to the affected area.

**True**

**False**

{text: Ch 2; p 24}

Comment: \_\_\_\_\_  
\_\_\_\_\_

16. If you know that someone has accidentally swallowed a pesticide, the best thing to do is make them vomit as quickly as possible.

**True**

**False**

{text: Ch 2; p 25}

Comment: \_\_\_\_\_  
\_\_\_\_\_

## Chapter 3 - Application Equipment

In addition to being able to safely lift and transport its cargo, an agricultural aircraft must be capable of accurately and safely dispersing a pesticide at the target site without jeopardizing adjacent lands or properties.

Both fixed and rotary wing aircraft are used in agricultural aviation; however, the majority of these are fixed wing aircraft (about 90% of the total.) Fixed wing aircraft offer the advantages of high speed and high payload capacity per dollar invested.

Rotary wing aircraft offer higher maneuverability, greater speed variability and may more easily apply pesticides in areas where conventional landing strips are unavailable. Rotary wing flying typically puts greater demand on the operator to perform applications with minimum time loss in turns and refilling. This is mainly because, per unit of flying time, rotary wing aircraft have higher operating costs than fixed wing aircraft.

### Dispersal Systems

Either liquid or dry formulations may be applied by aircraft. Regardless of type of pesticide formulation, dispersal metering must be accurate in order to apply the desired amount per acre of treatment site.

#### Liquid Dispersal

The dispersal system for a liquid pesticide consists of the hydraulic circuit shown in Figure 1.

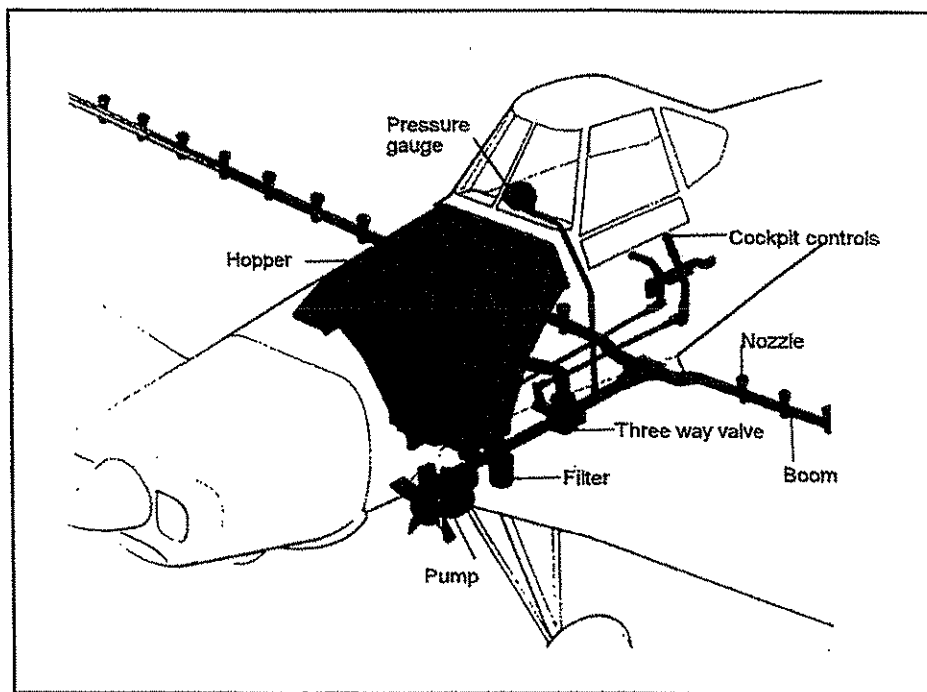

Figure 1. Liquid dispersal system for applying pesticide sprays.

## Tanks

The spray tank (hopper) is usually mounted in front of the cockpit and as close as possible to the center of gravity of the aircraft so that trim will not be affected as the tank empties. Most spray tanks are made of fiberglass.

Spray tanks on fixed wing aircraft have baffles to limit the sloshing of liquid during flight. An air vent ensures uniform emptying. Spray tanks have a large emergency gate through which the entire load can be dumped in a matter of seconds. Most spray tanks can be filled through an opening in the top, but it is usually more preferable (for both loader safety and operational ease) to fill through a pipe equipped with a quick-coupling valve. Typically, the fill pipe exits the side of the fuselage in the vicinity of the spray tank.

On fixed wing aircraft, the rear wall of the spray tank is usually visible from the aircraft cockpit. Typically, the rear wall of the tank has two sets of graduations printed on it. One graduation gives the gallons in the tank when on the runway and the other shows spray tank gallonage when the aircraft is in flight.

Spray tanks on rotary wing aircraft are usually mounted in pairs on each side of the fuselage. Piping connects the two tanks -- enabling the spray to be drawn equally from both tanks so the aircraft remains balanced. The twin tanks on most helicopters used in aerial application have relatively small capacities in comparison to fixed wing aircraft tanks. Total capacity is typically 100-150 gallons of spray mix.

## Pumps

Typically, the spray pump is powered by a fan mounted in the propeller's slipstream beneath the aircraft. Most pump fans are fitted with variable-pitch blades to enable pump speed adjustment.

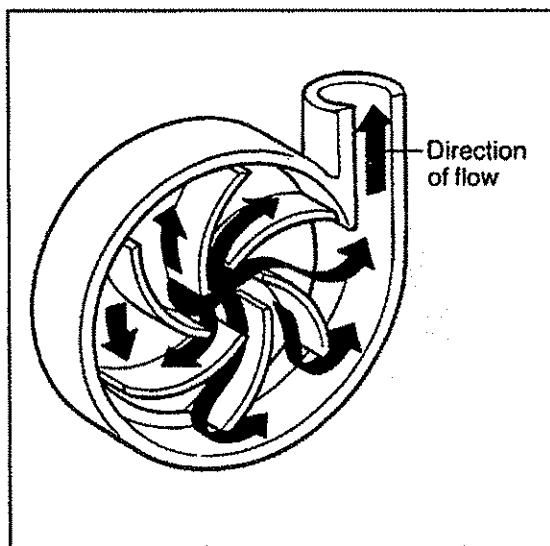

Figure 2. Centrifugal Pump

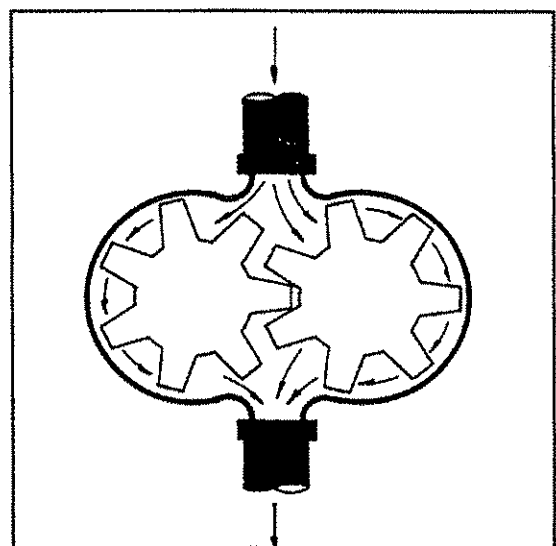

Figure 3. Gear Pump

The pump most widely used for aerial spray work is the **centrifugal pump**. A centrifugal pump delivers high gallons per minute (GPM) while working against a low pressure. This characteristic is well suited for most aerial application spraying because spray pressure is usually low (25-50 psi) and high GPM is usually desired (even for relatively low application rates) because the number of acres sprayed per unit of time by an aircraft is high. A typical performance curve for a centrifugal pump is portrayed in Figure 4.

If high spray pressure (>60 psi) is needed, a **gear pump** could be fitted. Gear pumps deliver low flow rates, but can work against a high pressure. A gear pump that can deliver the GPM needed for most aerial spraying jobs weighs much more than a comparable centrifugal pump. Weight, rapid wear when pumping abrasive formulations, and the requirement of a pressure relief valve account for gear pumps being used only where high pressure is needed. A typical performance curve for a gear pump is also portrayed in Figure 4.

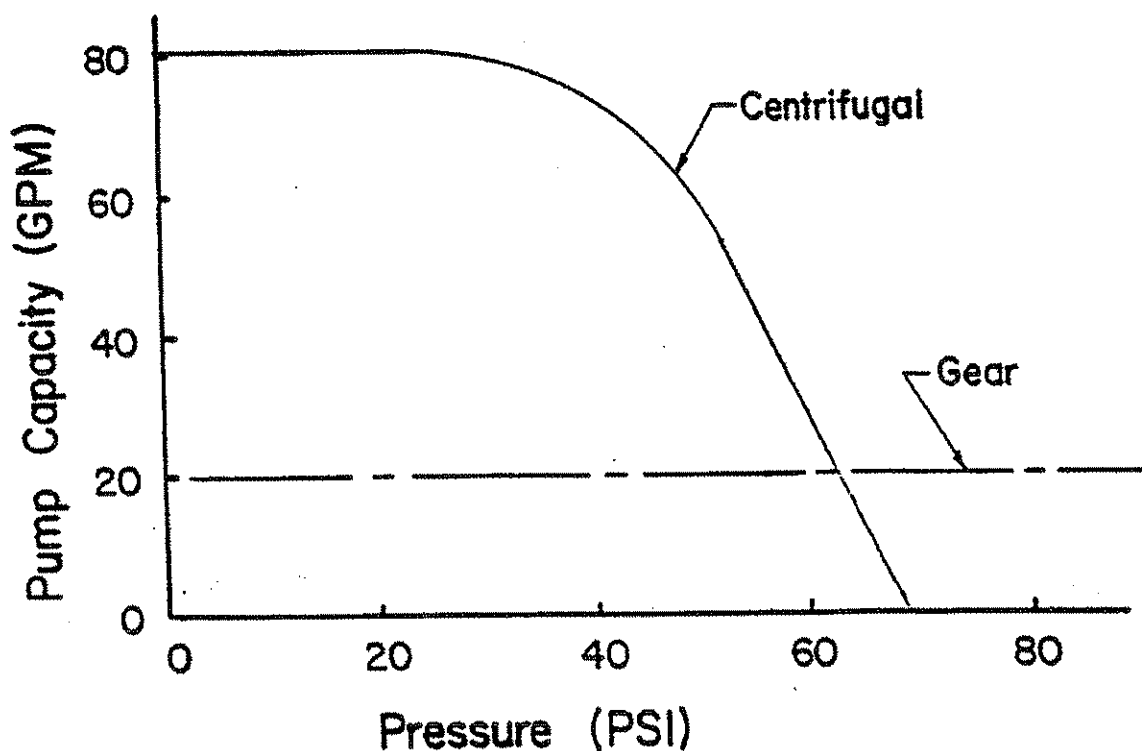

Figure 4. Pump performance curves for centrifugal and gear pumps.

### Agitation

Certain pesticide formulations (*e.g.*, wettable powders, flowables) *require* agitation to keep the pesticide evenly mixed with the spray carrier (water). Without agitation, the active ingredient in the spray mix will settle to the bottom of the spray tank -- which, in turn, will result in uneven dispersal (misapplication) of the pesticide at the application site. In-tank agitation of spray mix is usually accomplished by recirculation of pump output (via a bypass valve) during ferrying and

during turnarounds (when the boom is shut off.) For many situations, this amount of agitation is enough. However, when the treatment site consists of very long fields where turnarounds are infrequent, the spray pump must be capable of both supplying the spray boom and simultaneously providing adequate bypass agitation.

### Filters and Screens

Correctly sized line filters and nozzle filters (screens) help prevent nozzle tip clogging. Filter screen sizes range from 20 to 100 mesh. Smaller numbers indicate coarser mesh. Typically, the suction line filter between tank and pump should have a coarse-mesh screen. Coarse (low number) screens should not be used in nozzle bodies unless large-orifice nozzle tips have been selected.

### Piping and Fittings

The main piping and fittings on a spray plane should have large diameters (approximately 2 inches). This pipe size can accommodate the high flow rate typically needed for an agricultural spray plane. If a fixed wing aircraft is used exclusively for low volume work (e.g., public health pest control), smaller (e.g., 1-inch diameter) piping can be installed.

Small (1-inch diameter) piping is better suited to rotary wing aircraft -- this is because their slower airspeed makes lower flow rate usage possible. Aluminum, stainless steel, or chemical-resistant synthetic tubing is preferred for most spray system piping.

Spray system hoses are less likely to accidentally separate from fittings if the fittings are barbed or the hoses are double clamped, or both. Avoid restrictive (more than right angle) bends in spray system hosing or piping. Fit only chemical-resistant hose. Change any hose at first sign of swelling or cracking.

Use a positive shut-off valve to stop spray mix flow to the boom at the end of a spray run (before pullup) and when flying over pastures, lakes, streams and other sensitive areas. A shut-off valve that incorporates a tank return passage (Figure 5), reduces post-shutoff boom pressure.

Equip each nozzle body with a check valve to prevent dripping when the spray boom is shut off. Clean nozzle body check valves frequently. If you use diaphragm check valves, inspect the diaphragms regularly.

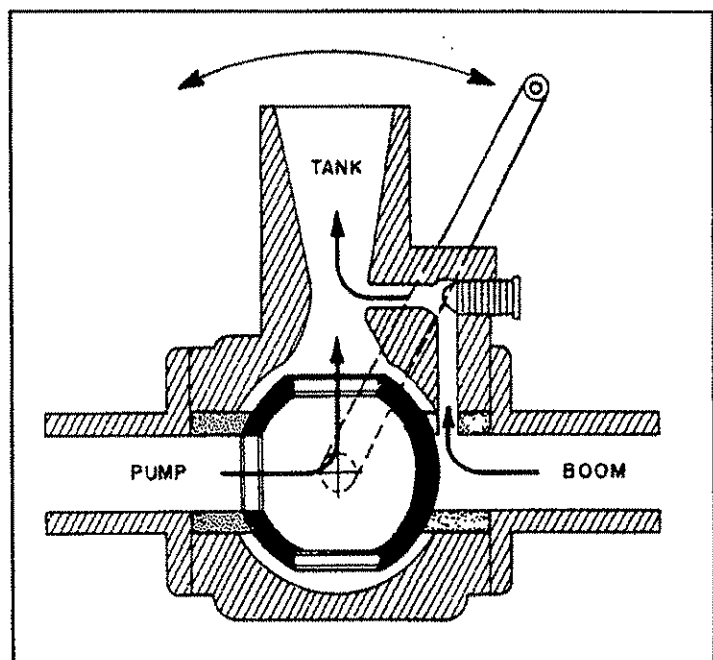

Figure 5

## Pressure Gauge

Prominently mount a pressure gauge in the cockpit so the pilot can readily monitor spray pump performance. Since liquid flow rate is directly related to pressure, desired pump pressure should be monitored during spraying. Pressure gauges can malfunction or the sensor line can plug. Periodically check the pressure gauge against a gauge known to be accurate.

Although a gauge to indicate pump pressure is valuable for monitoring pump and nozzle performance, it should not be used as the sole basis for selecting new nozzle tips from a nozzle manufacturer's table. Nozzle manufacturer tables give the gallons per minute (gpm) of *water* emitted by a particular nozzle tip at a prescribed pressure. The fluid properties of many pesticide spray mixes differ substantially from those of pure water. An applicator that installs nozzle tips solely from catalog-listed values and considers the aircraft calibrated is courting trouble. A field check of the spray dispersal system, as outlined in the calibration section of this manual, is always needed.

## Spray Booms

The fundamental purpose of the spray boom is to provide the best possible means for attaching an array of nozzles to the aircraft. Results of spray drift research indicate that nozzles are best positioned when their tips are placed in the least turbulent air. Thus, for most aerial application spray work, the spray boom should be positioned *well below and even with* (or well below and slightly behind) *the trailing edge of the wing*. Placing the nozzles in this zone largely frees them from airfoil-generated turbulence (*i.e.*, turbulence produced by re-convergence of the air that has flowed across the upper and lower surfaces of the wing.)

The cross-sectional shape of the spray boom influences actual spray droplet production. Boom-induced turbulence contributes to small spray droplet formation. *Airfoil* (wing-shaped) shaped booms produce the least turbulence -- hence an airfoil is the preferred cross-sectional shape for an aerial spray boom. *Slipstream* (oval or teardrop) shaped spray booms produce "intermediate" levels of turbulence. *Cylindrical* (pipe, tubing) booms create substantial air turbulence in the vicinity of the nozzle tips (even when the boom is located beyond the wing-induced turbulence zone) -- thus, cylindrical piping yields the least desirable cross-sectional shape for an aerial spray boom.

Spray boom *length* also influences aerial spraying performance. If nozzles are too close to the wingtip, spray output from these will be caught in the wingtip vortex. Spray droplets trapped by a wingtip vortex are swept upward and inward above the aircraft. This results in droplet size reduction. Producing small droplets increase the likelihood of spray drift. The entire problem is best solved by ensuring that nozzles are not positioned too close to a wingtip. Current spray drift research indicates that, for fixed wing aircraft, total functional boom length (the distance between the two most outboard nozzles) should not exceed 70% of the wingspan. For rotary wing aircraft, total functional boom length should not exceed 80% of rotor diameter.

## Nozzles

Aerial application rates are often classified as:

- conventional . . . . . (5 to 15 or more gallons per acre),
- low volume (LV) . . . . . (0.5 to 5 gallons per acre),
- ultra low volume (ULV) . . . . . (less than 0.5 gallons per acre).

Historically, aerial applications that disperse 15 or more gallons of spray mix per acre have been avoided when possible -- largely because of lowered work efficiency reasons (higher operational costs arising from increased time spent in tank refilling, ferrying, etc.) In practice, a "conventional rate" was preferably less than 8 gallons of spray per acre. Conventional rate aerial applications have typically been accomplished by a boom fitted with cone pattern nozzles. Recent findings of aerial spray drift research indicate that spray output from cone pattern nozzles are likely to emit drift-prone spray droplets unless the cone pattern tips have been configured to produce coarse spray droplets. Coarse droplet sprays require higher gallonages per acre to achieve sufficient target site coverage.

Application rates in the low volume (LV) range are often well suited for agricultural target sites that require treatments of "protectant" fungicides on a recurring basis. In such instances, cone pattern nozzles *without cores* may produce a useful droplet spectrum with a lowered risk of driftable (fine) spray droplets. Flat fan or CP nozzles set to a low deflection angle may also be used for LV rate work. Drift research indicates that properly-installed straight-stream CP nozzles can significantly lower drift risk.

When vegetable oil carriers are used, or when concentrates are used in forest or public health pest control (e.g., mosquito abatement spraying) ULV application rates may be as low as a few ounces per acre. For ULV applications, rotary atomizers are often used.

### Cone Pattern Nozzles

The two most commonly encountered cone pattern nozzles are the *disc-core* type and the *whirl-chamber* type -- but these no longer dominate as they once did.

A *disc-core nozzle* is designated by the size of its disc orifice and the size of its core. Various disc and core sizes are available. A disc orifice is measured in 1/64th inches. Hence, a D8 disk has an orifice diameter of 8/64ths inches. There is no simple code for identifying cores. Core sizes include #13, 23, 25, 31, 35, 45, 46, and 56. A core identified by a bigger number has

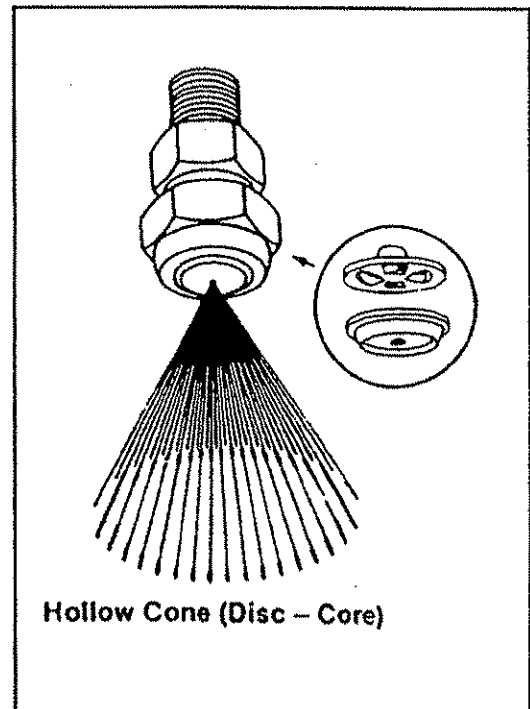

Figure 6



either more holes or bigger holes than a core that has a smaller number. Disc-core nozzles are typically referred to by combining their parts numbers; thus, a D7-56 designates a D7 disc mated up with a # 56 core. Figure 6 illustrates a disc-core type nozzle and a core.

The disc-core combination determines the gallons per minute (gpm) rating of the nozzle at a given pressure. For example, a D7-56 delivers 1.52 gpm at 40 psi while a D7-45 combination only delivers 0.68 gpm at 40 psi. When mounting disc-core nozzles on an aircraft, orient the raised mound on the core upstream in the nozzle body.

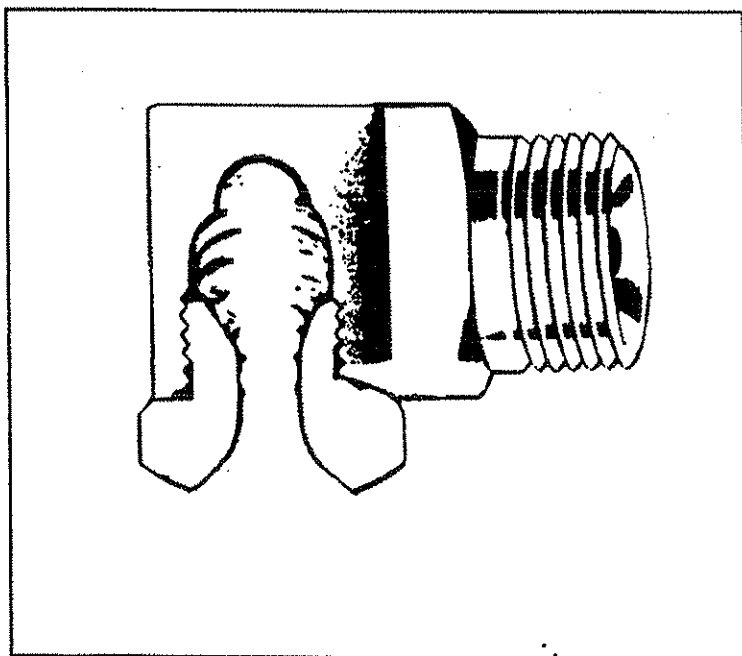

Figure 7

A *whirl chamber nozzle* consists of a specialized nozzle body and a nozzle cap. When liquid enters a whirl chamber nozzle body, the interior architecture of the nozzle body causes the liquid to whirl rapidly before exiting as a cone-shaped spray pattern. Whirl chamber nozzles are relatively free from clogging problems. However, recent spray drift research indicates that because the spray emerges in a conical pattern, using whirl chamber nozzles on an aerial spray boom can be expected to yield a disproportionate amount of very fine, drift-prone, droplets. Figure 7 is a cut-away view of a whirl chamber nozzle.

### Fan-Pattern Nozzles

*Flat fan* (and *even flat fan*) nozzle tips produce flat, fan-shaped, spray patterns. The exact angle of the fan-shaped pattern produced by flat fan (and even flat fan) nozzle tips depends on nozzle design, at-nozzle spray pressure, and the physical characteristics of the pesticide spray mix. Nozzle tips designed to produce fan-shaped patterns having angles of 65, 80 or 110 degrees are available. In general, fan nozzle tips that produce wide angles tend to generate more drift-prone spray droplets. For this reason, fan nozzle tips designed to emit no more than an 80-degree spray pattern are better suited for aerial spray applications.

Recent aerial spray drift research findings indicate that nozzles which emit fan-shaped spray patterns typically produce fewer drift-prone spray droplets than do cone-pattern nozzles. Nozzle design engineers continue to develop new nozzle tip architectures that capitalize on this finding. From their effort, several "speciality" tips that (when configured and operated properly) can help

reduce drift-prone droplet formation (e.g., floodjet, air-induction, turbulence-chambered, etc.) are now commercially available. Although they work in different ways, they all aim at the same goal: minimization of driftable fines without completely sacrificing spray coverage capability. To date, this remains a goal – not an accomplishment. For a more complete discussion of spray drift management, please see Chapter 4 of this manual.

Traditional fan pattern nozzle tips are designated by an alpha-numeric code indicating fan angle, flow rate through the tip when spraying water at 40 psi, and fan pattern footprint. The major suppliers of traditional flat fan nozzles are Spraying Systems, Inc., and Delavan Corp. Fan nozzle tip codes used by these manufacturers are explained below.

Spraying Systems, Inc. -- Fan pattern nozzle tips marketed by Spraying Systems are encoded with a 4 (or 5) digit number that is optionally followed by one or more letters. Any 5-digit code that begins with a "1" indicates the tip's spray angle is greater than 100-degrees. When the first digit is a "1", the first three digits denote the spray angle. For codes not beginning with a "1", the first two digits of the code denote spray angle. The remaining numbers of the code denote the flow rate in gallons per minute (gpm) at some "standardized" pump pressure (psi). The gpm value is interpreted by placing a decimal point between the first two digits of the flow rate portion of the code. A series of letters may optionally follow the numerical portion of the code. Such letters are abbreviated descriptions of other properties of the nozzle tip (e.g., SS=Stainless Steel, LP=Low Pressure, E=Even Fan Pattern.)

**Example:** Spraying Systems Teejet 11002LP-SS

"110"	--	110-degree spray pattern
"02"	--	0.2 gpm (spraying water at a "standardized" pressure)
"LP"	--	nozzle tip is designed for low pressure (15 psi) work
"SS"	--	nozzle tip is made of stainless steel

**Example:** Spraying Systems Teejet 80015EVS

"80"	--	80-degree spray pattern
"015"	--	0.15 gpm (spraying water at a "standardized" pressure)
"E"	--	spray pattern is evenly distributed
"V"	--	nozzle tip is Visi-Flo color coded
"S"	--	nozzle tip is made of stainless steel

Evenly distributed flat fan nozzles have little effect on the spray distribution applied by an aircraft. The more important consideration when using flat fan nozzles on an aerial boom is to ensure the nozzle tip produces a narrow spray angle.

Delavan Corporation -- The nozzle code used by Delavan is similar to the one described previously. The principal difference is the order of the alpha-numeric code.

**Example:** Delavan LF-280

- "L" -- nozzle tip is rated for low pressure
- "F" -- nozzle tip produced a flat spray pattern
- "2" -- 0.2 gpm flow at 40 psi
- "80" -- 80° spray angle

### CP Nozzles

Conceived and developed by ag pilot G.O. Christopher during the 1980's, the standard CP aerial nozzle first became commercially available in 1991. The standard CP nozzle disperses liquid in a *flood-type flat fan pattern*. Rather than using sculpted chambers, swirl plates, discs or cores, the CP nozzle utilizes a nozzle body and two manually operated adjusters (*selector* and *deflector*).

The CP *nozzle body*, in conjunction with pump pressure, primarily governs nozzle flow rate. The nozzle *selector* bears 4 orifices of different sizes and has an "off" position. Changing the nozzle orifice selector alters the diameter of the nozzle's throughput stream. Spray mix flowing through the selected orifice reaches the second adjuster -- the *deflector*. The deflector acts as an anvil surface for the stream of spray mix being emitted. Working together, the selector and deflector form spray droplets. Because deflector angle is adjustable, the applicator can configure the nozzle to produce fine, medium or coarse spray droplets.

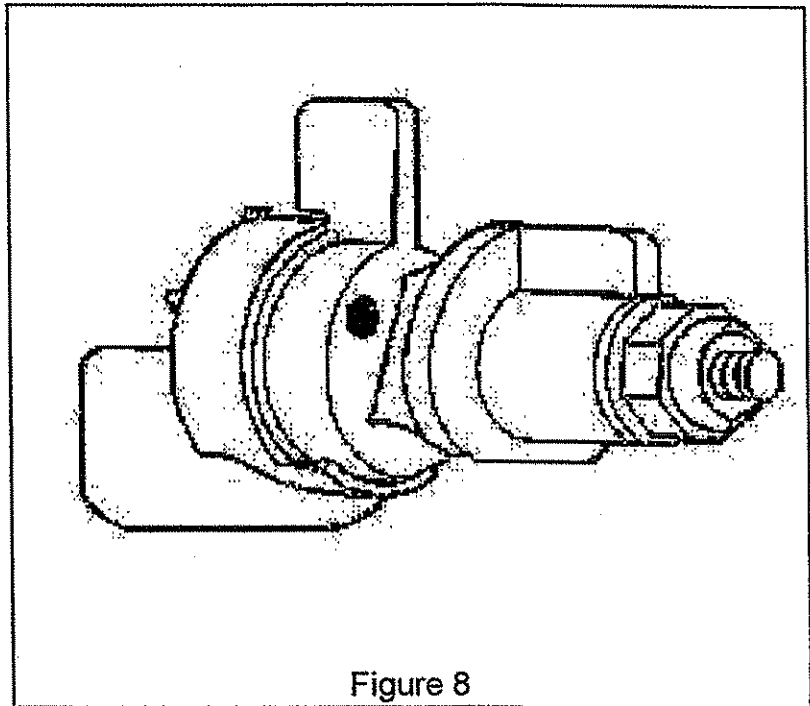

Figure 8



## Rotary Atomizers

Rotary atomizers are more expensive than conventional nozzles, but some aerial applicators prefer them because of their versatility. Rotary atomizers can apply a wide range of application rates and generate small or large droplets. The atomizer is rotated by a variable-pitch propeller, by hydraulics, or by electricity. Spray mix is supplied to the center of the atomizer body, is flung outward by centrifugal force, and ultimately passes through a rotating screen. Spray droplet size is determined by the atomizer screen's rotational speed. Because rotary atomizers have relatively large metering orifices, they are less prone to clogging than small-orificed conventional nozzles. Typically, a single rotary atomizer can generate a swath of 10-15 feet.

## Spray System Operating Pressure

*For any nozzle tip, nozzle output rate (gallons per minute per nozzle) is proportional to the square root of the spray pressure.* In practice, this means that if one wants to use spray pressure to double (2X increase) the output rate of a nozzle, the spray pressure must be quadrupled (4X increase.) If the nozzle does not allow for independent adjustment for droplet size, a large increase in spray system pressure will substantially increase the number of small droplets generated. Thus, increasing spray pressure increases nozzle tip wear rate, power requirement, and spray drift potential.

In most cases, changing boom output rate is best achieved by changing nozzle tip size, nozzle orifice size, or by changing the number of nozzles in use. Typically, altering spray system pressure should be used only to make very minor changes (alterations of 10% or less) in boom output.

Spray system operating pressure should always be the lowest pressure needed for effective spray system function. Typically, spray system pressure should be in the 15-35 psi range when using conventional or CP nozzles.

## Nozzle Anti-Drip Devices

Fit each nozzle on the boom with its own check valve. Modern designs typically utilize either a *diaphragm check valve* (e.g., Teejet) or a *needle-and-seat check valve* (e.g., CP Products.)

When spray pressure in the boom is less than 7 psi, a diaphragm check valve will close the fluid passageway leading to the nozzle tip -- thereby preventing a low pressure drip of spray mix from the nozzle while the spray boom is shut off. A cut-away view of a diaphragm check valve is shown in Figure 11.

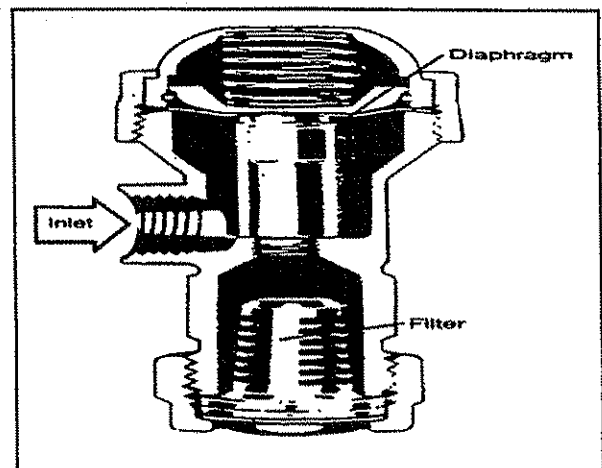

Figure 11

Needle-and-seat check valves (e.g., CP Products check valves) provide a means to easily flush debris from the check valve body without removing the top to clean (or change) the check valve diaphragm. An exploded view of a needle and seat check valve is shown in figure 12.

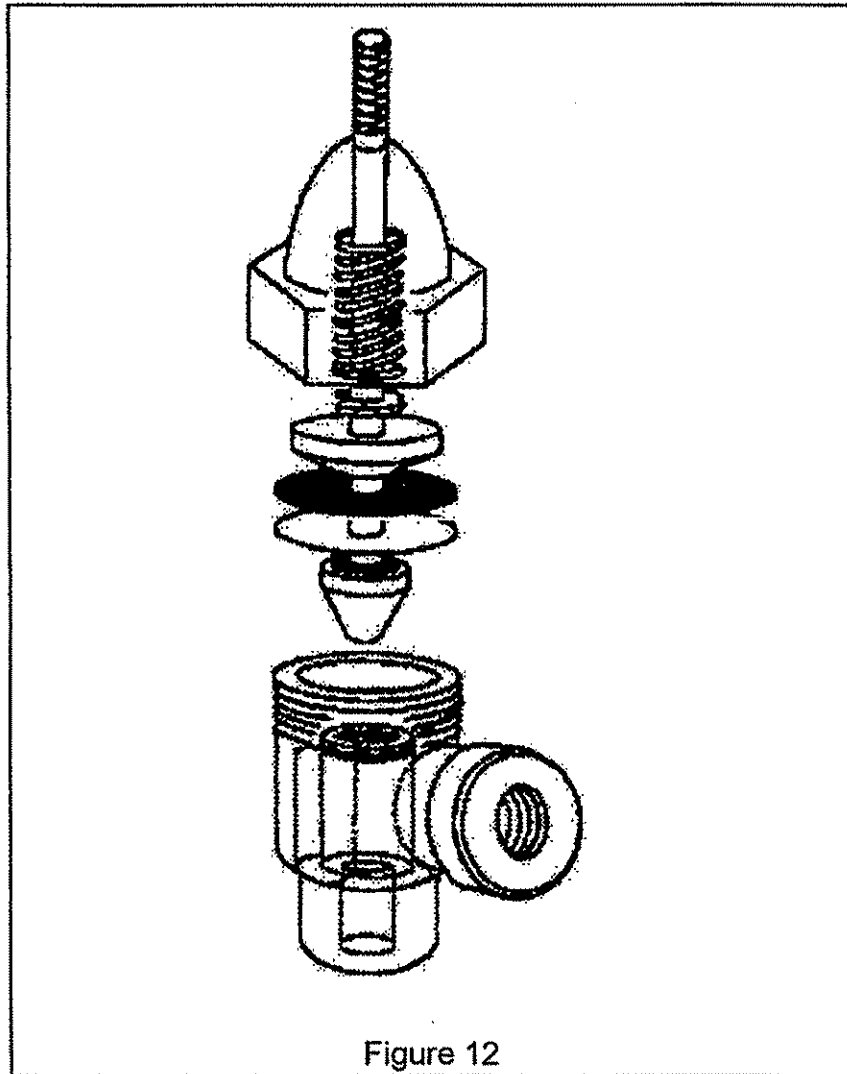

Figure 12

## Dry Dispersal

On fixed-wing aircraft, dry formulations of pesticide (e.g., products applied as granules or pellets) are dispersed through a ram-air spreader (Figure 13). Rotary-wing aircraft typically use a centrifugal spreader (Figure 14 (see page 47)) to apply dry formulations.

### Ram-Air Spreader

Because of the considerable drag that results from their being placed in the high speed airstream, conventional ram-air spreaders always compromise aircraft performance. However, ram-air spreaders have survived a long list of "improved" designs because they are comparatively simple, versatile, and reasonably priced.

Typically, a ram-air spreader is secured beneath the fuselage in a manner that facilitates removal for returning the aircraft to liquid spraying capability (Figure 13).

For ram-air spreader service, the hopper used to hold dry pesticide products (granules, pellets) is the same hopper as that used to carry liquid spray mixes (i.e., the spray tank). The dry pesticide product drops from the hopper into a ducted airstream, where it is accelerated rearward until ejected rearward and laterally by airflow.

Dry formulation pesticide products can be applied very uniformly by fixed wing aircraft fitted with a properly configured ram-air spreader; however, setup and operation may be more complex than that required for applying a liquid pesticide product at the same site. General limitations imposed by ram-air spreaders include:

- high aerodynamic drag, and
- high power requirements.

Typically, unsatisfactory *single-pass* distribution patterns result from most ram-air devices if the target site application rate is either:

- less than 50 pounds per acre,
- more than 250 pounds per acre, or
- if the targeted ejection rate is more than 35 pounds per second.

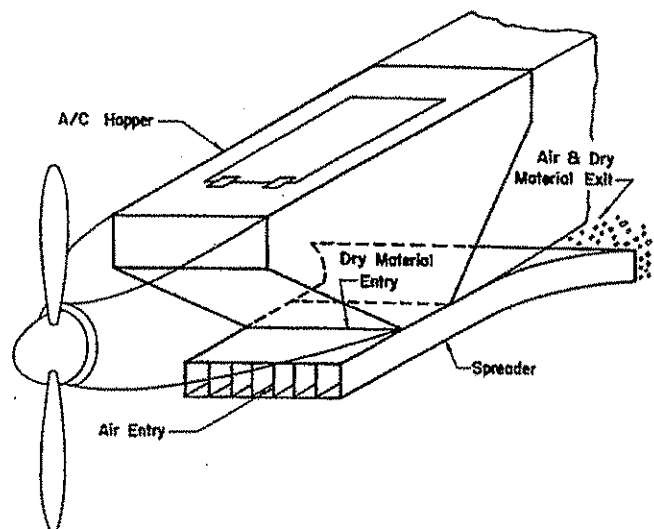

Figure 13. Ram air spreader for applying dry materials.

## Feed Rate

The feed rate of dry pesticide being supplied to a ram-air spreader is principally governed by a metering gate situated between the hopper floor and the spreader throat. Usually, the hopper-to-spreader metering gate is either:

- hinged (e.g., Transland type), or is
- a sliding hatch (e.g., Grumman type.)

Hinged metering gates are opened by linkage that rotates the trailing margin of the gate surface downward. Material escapes from the hopper by flowing over the opened gate's lowered edge. Often, hinged gates are intended as dual-purpose devices-- *i.e.*, designed to be capable of dispensing either dry or liquid formulations. In some cases, hinged gates designed for dual purpose also have a rubber gate cover that functions as a gasket (to aid fluid containment). Uneven wear of the gasket (or metering gate surface) commonly contributes to uneven feed of dry formulation unless corrective measures (maintenance) are undertaken. In general, hinged metering gates require more frequent calibration adjustment than do sliding hatch types -- this is largely a consequence of hinged gates being designed for dual-purpose (wet or dry) use.

Sliding hatch (e.g., Grumman) styles of hopper metering gates are usually *not* intended for dual-purpose use. Sliding hatch styles generally require less effort for proper adjustment -- especially for low application rates -- but tend to be somewhat more prone to overall wear. Most sliding hatch metering gates are not designed to dispense liquid formulations.

Regardless of design, a hopper metering gate *must provide even feed* across its opening. Uneven hopper-to-spreader feed due to uneven metering gate adjustment is almost certain to cause an uneven ram air spreader swath pattern. It is unreasonable to expect any combination of other ram-air spreader adjustments to entirely compensate for swath pattern problems caused by uneven gate feeding of a dry formulation.

Regularly conduct a preflight metering gate test to ensure that pesticide product in the hopper flows evenly and uniformly through the metering gate. Evaluate particle flow at all gate aperture settings. Give particular attention to lower (small gate aperture) settings. Even flow through the metering gate is critically important for uniform treatments of dry material at low application rates.

Substantially increasing the hopper-to-spreader feed rate is a poor strategy for increasing application rate. When too much dry pesticide product is metered in, the spreader ducting becomes choked and less air is able to flow through the unit. Increasing the amount of dry pesticide entering the spreader requires more air, not less, to convey the material through the spreader.

## Spreader Vanes

The air channel of a typical ram-air spreader consists of several (5-13) laterally adjacent, curved ducts. The partitions that form the "walls" of these ducts are usually referred to as the spreader's



*vanes*. Each spreader vane typically has two adjustable sections -- located at the front and rear of a vane. These adjustable sections allow for lateral repositioning of the inlet and exit portions of a given vane within the spreader body. In consequence, the influence that a given duct has on both the amount of the dry pesticide product being drawn from the hopper and the spreader's resultant dispersal pattern (uniformity) is adjustable. Vane adjustment enables fine-tuning of a ram-air spreader to a particular airframe.

In a ram-air spreader, the material metered from the hopper flows through the ducts as a thin (approximately 1/2-inch thick), sheet-like layer of particles. Forced rearward by air entering the spreader inlet, the layer of particles flows along the internal surface (ceiling) of the spreader's upper skin. Spreading (predictable lateral re-direction) of the particle layer is the main job of the spreader's vanes. When functioning correctly, spreader vanes prevent air and particles from moving from one duct to another.

For its entire length (including movable sections), the top of each vane **MUST contact the internal surface** (ceiling) of the spreader's upper skin. If any air gap occurs (due to wear, poor construction, etc.) between vane and duct ceiling, both air and particles can move uncontrollably from one duct to another during spreader operation. If this condition exists, no amount of vane adjustment will alter spreader performance. *Spreader that have air gaps existing between the vanes and the internal surface of the top skin must be repaired before any attempt is made to put the spreader into service.*

The position of a spreader's inlet vanes is often a key factor influencing the amount of pesticide product appearing within any given portion of a ram-air spreader's swath pattern. For this reason, inlet vane repositioning is typically used to make major adjustments toward ram-air spreader swath uniformity. Airframe-induced influences known to affect ram-air spreader performance that can often be compensated for by spreader inlet vane adjustment include: oil-cooler-induced turbulence, speed ring effects, propwash effects, and turbulence caused by flagging device air deflectors.

For example, *propwash effect* typically causes material released near the right of the fuselage to become displaced to a region adjacent the left side of the fuselage. In result, the swath is non-uniform (right side sparse, left side too heavy.) To correct a propwash-induced problem, a ram-air spreader should be configured to discharge more material from its right side than from its left. This is best accomplished by moving the spreader's inlet vanes toward the left. (Moving the inlet vanes leftward makes the duct inlets supplying the spreader's left side smaller than those supplying its right side.) In consequence, the spreader will discharge more product from its right side -- some of which will ultimately be steered leftward by propwash -- with the net result being a more uniform swath.

Shifting inlet vanes too far laterally can cause unproductive consequences. As an inlet vane is shifted laterally, the airstream attack angle (angle of incidence) of the duct wall increases. When a duct wall's angle of incidence is too great, static air pressure increases within the duct and impairs

hopper-to-duct flow rate. The result is an undesired reduction of spreader output. As a general rule, lateral repositioning of an inlet vane should never be so much as to cause a duct wall's inlet orientation to exceed a 15-degree angle of incidence (as measured in relation to path of forward flight.)

Altering the spreader's exit configuration is accomplished by repositioning the adjustable rear portion of one or more spreader vanes. The vanes in some spreaders do not have adjustable rear sections. For those that do, adjustment of rear vane sections provides a way to fine tune overall swath pattern uniformity. This is because the position of a vane's rear section mainly influences the exit direction of the particles passing through that vane's duct.

Adjustment of a vane's rear section should, as much as possible, smoothly follow the arc formed by the vane's rigid internal curvature. For rear vane adjustment, the key concepts are *smooth, non-obstructive, non-impeding, exit airflow changes*. Generally, this is best accomplished by *small* rear vane adjustments. An abrupt change in exit vane curvature (over-adjustment) will usually cause particles moving through the duct to slow down -- making particle re-direction unlikely -- instead, the most likely result is that the swath portion supplied by an abruptly-changed vane will contain excessive material.

## Spreader Mounting

The best possible mounting of a ram-air spreader is the one which causes the least possible turbulence. Having the smoothest possible airflow into, around, and out of the spreader is an invaluable asset for both tuning spreader performance and accomplishing desirable application results. For this reason, one is well served to pay special attention to every seemingly small detail of spreader mounting points and mount connector orientation (making sure that these induce minimal turbulence.) On many occasions, turbulence produced by improperly positioned quick connectors has caused a swath pattern problem.

Relative to an aircraft's *roll* axis, a correctly-mounted spreader hangs *level* beneath the fuselage. Also, relative to the airframe, the mounted spreader should exhibit *zero degrees of yaw*. Spreader mounting differs from airframe orientation only in one aspect: *pitch*. The attack angle of a ram air spreader directly influences the amount of airflow entering the spreader inlet. Spreader attack angle is set by establishing the pitch of the spreader body at mounting.

The forward mounting points of ram-air spreaders are usually fixed (non-adjustable.) In consequence, spreader attack angle is adjusted by changing the distance between the fuselage and the spreader's tail. Typically, the lower skin of the spreader is the reference surface for assessing spreader attack angle. As a general rule, the attack angle of a spreader's lower surface should be slightly less (approximately 1 to 3 degrees less) than the attack angle of the lower surface of the aircraft wing. When a spreader tail is mounted either too low or too high, the likely result is increased turbulence and drag, increased deposition of formulated pesticide on the aircraft's tailgear, a non-uniform swath pattern, and swath narrowing due to lowered exit speeds of particles.

## Rate and Swath

*Hopper gate metering rate, effective duct separation, spreader vane positioning* (both front and rear), and *spreader mounting* are major device-specific factors influencing key ram-air spreader performance considerations -- notably: swath uniformity, swath width, and actual application rate (pounds per acre). Moreover, it is well worth remembering that these (especially swath width and actual application rate) are interrelated.

Up to the point of its maximum material handling capability, changing a spreader's application rate automatically changes its effective swath width. The relation between these is inverse. This means that increasing hopper feed to the spreader will cause a decrease in swath width. (Reason: as the particle stream exiting a spreader duct becomes heavier, it also becomes less prone to being broken up.) Thus, for high application rates (jobs requiring more than 250 pounds of pesticide product per acre), often the best strategy is to *reduce the per-pass application rate, configure the spreader for a reduced swath width, and fly more passes per site using a standard* (normal progression) *flight pattern*.

## Centrifugal Spreader

The centrifugal spreader used by rotary-wing aircraft is a self-contained unit having its own hopper. The dry pesticide is metered (via a gate) from the hopper onto a spinning disc (spinner) that distributes the pesticide. The spinner is usually driven by a hydraulic motor (or an integral gasoline engine) controlled by the pilot via hydraulic control cable or radio. The entire unit is suspended on cable and carried beneath the helicopter.

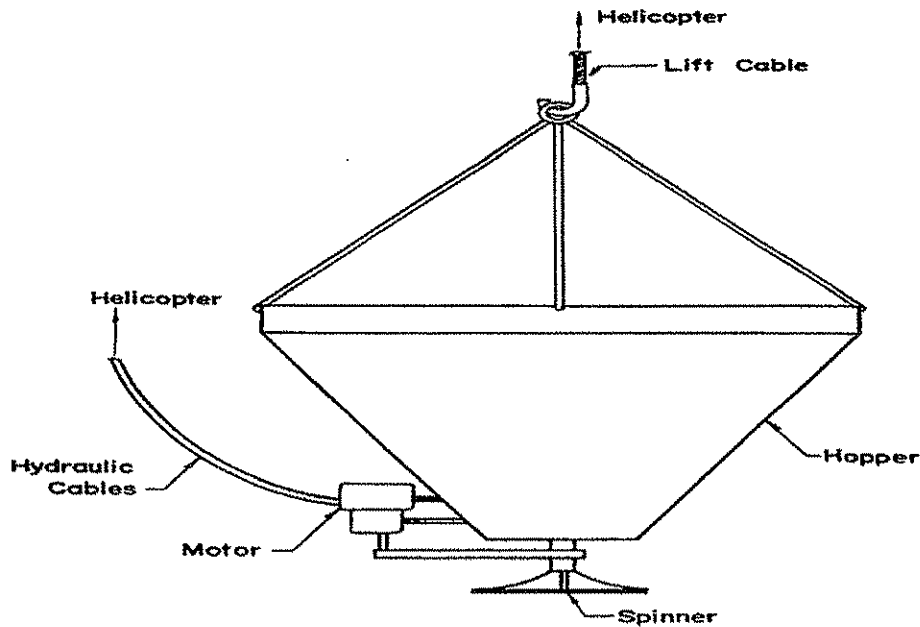

**Figure 14.** Centrifugal spreader for applying dry materials with rotary wing aircraft

## Review Questions for Chapter 3

*(Answers: page 193)*

01. In general, the capability of delivering comparatively high boom outputs while working against a relatively low spray pressure makes the centrifugal pump well suited for many aerial application equipment configurations.

**True**

**False**

{text: Ch 3; p 33}

Comment: \_\_\_\_\_  
\_\_\_\_\_

02. Gear pumps characteristically deliver high flow rates at very low hydraulic pressures.

**True**

**False**

{text: Ch 3; p 33}

Comment: \_\_\_\_\_  
\_\_\_\_\_

03. Unless the spray plane is being set up exclusively for low volume work (e.g., public health pest control), hydraulic system plumbing should generally have tubing diameters greater than 1-inch.

**True**

**False**

{text: Ch 3; p 34}

Comment: \_\_\_\_\_  
\_\_\_\_\_

04. Boom shutoff valves that lack a tank return passage work best for minimizing post-shutoff boom pressure.

**True**

**False**

{text: Ch 3; p 34}

Comment: \_\_\_\_\_  
\_\_\_\_\_

## Review Questions for Chapter 3

(Answers: page 194)

05. Because most pesticide spray mixes have viscosities virtually identical to that of pure water, an applicator can accurately predict spray boom performance by reading the nozzle-tip data (gpm) provided by nozzle manufacturers.

**True**

**False**

{text: Ch 3; p 35}

Comment: \_\_\_\_\_  
\_\_\_\_\_

06. A spray boom that appears oval or teardrop in cross-section (slipstream styling) typically produces less turbulence than a boom having an airfoil cross-sectional shape.

**True**

**False**

{text: Ch 3; p 35}

Comment: \_\_\_\_\_  
\_\_\_\_\_

07. In most cases, total functional boom length should not exceed 70% of wingspan.

**True**

**False**

{text: Ch 3; p 35}

Comment: \_\_\_\_\_  
\_\_\_\_\_

08. For rotary aircraft, boom length should be at least 120% of rotor diameter.

**True**

**False**

{text: Ch 3; p 35}

Comment: \_\_\_\_\_  
\_\_\_\_\_

## Review Questions for Chapter 3

*(Answers: page 194)*

09. Nozzles that emit conical spray patterns always produce fewer drift-prone spray droplets than do nozzles which emit fan-shaped spray patterns.

**True**

**False**

{text: Ch 3; p 37}

Comment: \_\_\_\_\_  
\_\_\_\_\_

10. CP nozzles generate spray droplets by causing spray mix liquid to be flung outward from the center of an atomizer body and passed through a rotating screen.

**True**

**False**

{text: Ch 3; p 39}

Comment: \_\_\_\_\_  
\_\_\_\_\_

11. In general, needle-and-seat check valves tend to be more labor intensive to clear of clogs than are diaphragm check valves.

**True**

**False**

{text: Ch 3; p 42}

Comment: \_\_\_\_\_  
\_\_\_\_\_

12. Virtually all modern ram air spreaders are designed to eject a minimum of 50 pounds of medium per second.

**True**

**False**

{text: Ch 3; p 43}

Comment: \_\_\_\_\_  
\_\_\_\_\_

## Review Questions for Chapter 3

(Answers: page 194)

13. A ram air spreader device fitted with a hinged metering gate will usually require calibration adjustment less frequently than will a spreader fitted with a sliding hatch metering gate.

True

False

{text: Ch 3; p 44}

Comment: \_\_\_\_\_  
\_\_\_\_\_

14. At very low application rates of dry products, an unevenly set feed gate is less likely to influence application uniformity.

True

False

{text: Ch 3; p 44}

Comment: \_\_\_\_\_  
\_\_\_\_\_

15. The most effective strategy for increasing application rate of a dry material is to substantially increase the hopper-to-spreader feed gate setting.

True

False

{text: Ch 3; p 44}

Comment: \_\_\_\_\_  
\_\_\_\_\_

16. To function as intended, spreader vanes **MUST** contact the internal surface the spreader's skin (i.e., the spreader ceiling.)

True

False

{text: Ch 3; p 45}

Comment: \_\_\_\_\_  
\_\_\_\_\_

# Review Questions for Chapter 3

(Answers: page 194)

17. Inlet vane repositioning is typically used to make major adjustments toward ram-air spreader discharge uniformity.

**True**

**False**

{text: Ch 3; p 45}

Comment: \_\_\_\_\_  
\_\_\_\_\_

18. Decreasing the spacing between adjacent inlet vanes increases airspeed through that duct; thus, such an adjustment increases the discharge rate from that region of the spreader.

**True**

**False**

{text: Ch 3; p 46}

Comment: \_\_\_\_\_  
\_\_\_\_\_

19. The best possible mounting of a ram-air spreader is one which causes the least possible turbulence.

**True**

**False**

{text: Ch 3; p 46}

Comment: \_\_\_\_\_  
\_\_\_\_\_

20. Increasing a ram-air spreader's hopper feed rate will typically cause an increase in the spreader's swath width.

**True**

**False**

{text: Ch 3; p 47}

Comment: \_\_\_\_\_  
\_\_\_\_\_



## Chapter 4 – Drift Management

### Definition of “Pesticide Drift”

Established in 1990, the Spray Drift Task Force (SDTF) has designed, conducted and analyzed numerous experiments in many different parts the United States. The principal reason for the nationwide SDTF effort is to obtain a better understanding of the relationships between the main factors that significantly influence pesticide drift. The National Coalition On Drift Minimization (NCODM) tenders certain findings of the SDTF.

The NCODM currently defines *pesticide drift* as:

“...the physical movement of pesticide through the air at the time of pesticide application or soon thereafter from the target site to any nontarget or off-target site.”

To more fully define pesticide drift, the NCODM goes on to state:

“Pesticide drift shall not include movement of pesticides to non-target or off-target sites caused by erosion, migration, volatility, or windblown soil particles that occurs after application unless specifically addressed on the pesticide label with respect to drift control requirements.”

Pesticide drift is not caused by a single factor; findings of recent studies underscore the following points:

- Spray drift *only occurs downwind*.
- Spray *droplet size is the single-most important factor* affecting spray drift.
- *Release position* (boom height & length) and *wind speed* importantly affect spray drift.
- Spray drift is *manageable*.
- Pesticide applicator decisions and actions before and during target site treatment cannot be expected to eliminate spray drift -- but can greatly *minimize* it.

# Why Be Concerned About Drift?

The main reasons for being concerned about spray drift are:

- Agricultural chemicals are expensive -- spray drift is money wasted.
- Off-target pesticide application typically violates a pesticide product's label language. Target *pest* does not govern product usage legality -- *target site* does. **(Thus, application to a site not mentioned on the pesticide product label constitutes illegal application.)**
- Pesticide drift may induce damage to (or unlawful residues on):
  - ☞ non-target crops,
  - ☞ human or domestic animal habitat,
  - ☞ wildlife environments.

## Droplet Size

The diameter of a spray droplet is usually measured in *microns* (abbreviated  $\mu m$ ). A micron is one millionth of a meter -- the equivalent of 1/25,400th of an inch. Spray droplets whose diameters are less than 100  $\mu m$  are not visible to the unaided human eye. Spray droplets that have diameters 150  $\mu m$  or smaller can (and do) remain airborne for a significant time (typically, they become even smaller due to evaporative loss while airborne.) **Spray droplets having diameters less than 150  $\mu m$  (approximately the diameter of coarse human hair) are the chief constituents of most drifting pesticide spray.** Configuring and operating an application equipment's spraying system to substantially curtail drift-prone droplet formation without wholly sacrificing target site coverage capability is the practical focal-point of most spray droplet size management efforts.

Regardless of its design, a normally-functioning nozzle tip produces spray droplets of different sizes. From the standpoint of spray droplet size, the entire range of outputs generated by a given nozzle tip is referred to as its *droplet size spectrum*. A spectrum is an intergrading array. Thus, droplets emitted from a nozzle tip can be arrayed (their sizes ranging from extremely small to very large) on a continuous gradient for descriptive purposes. A "plain-English description" of a few droplet sizes that might be found in a nozzle tip's droplet spectrum illustrates this concept (see Table 3.)

**Table 3. Characterization of Various Droplet Sizes**

Type of Droplet	Diameter ( $\mu\text{m}$ )
Dry Fog	5
Wet Fog	20
Light Mist	50
Misty Rain	100
Light Rain	200
Medium Rain	500
Heavy Rain	1000

Fluid engineers use various discrete parameters, such as *volume median diameter* (VMD), to characterize a nozzle tip's droplet size spectrum. The term VMD is not new; it regularly occurs in literature about spray droplets. The VMD is the droplet diameter at which one half of the total volume of liquid being emitted as spray is composed of larger droplets and the other half of the emitted volume is made up of smaller droplets. VMD is mainly helpful for predicting a nozzle tip's capacity to provide spray coverage. Although VMD is useful for describing the "spread" of droplet sizes present in a given droplet spectrum, *it is not especially useful for describing a nozzle tip's drift potential*. The main drawback is that VMD fails to indicate what proportion (percentage) of the emitted spray is being released as drift-prone droplets.

Why are small droplets more drift prone than large ones? *The fall rate of a spray droplet is roughly proportional to the square of the droplet's diameter*. In practical terms, this means a 200  $\mu\text{m}$  droplet (which is 10 times the diameter of 20  $\mu\text{m}$  droplet) has a settling velocity (fall rate) that is approximately  $(200/20)^2 = (10)^2 = 100$  times faster than the 20  $\mu\text{m}$  droplet. Table 4 shows the velocities at which various size droplets can be expected to fall in still air.

**Table 4. Droplet Settling Velocities**

Droplet Diameter ( $\mu\text{m}$ )	Settling Velocity (ft./min.)
200	231.0
100	59.0
80	38.0
50	14.7
40	9.6
20	2.4
10	0.6

Spray droplets that have low settling velocities remain suspended in the air much longer than larger ones do. *Because small spray droplets remain suspended much longer, the probability of their being swept from the target site by an air current (i.e., drifting) is much greater.*

## Equipment Factors Affecting Droplet Size

A pesticide applicator can dramatically alter spray droplet size by adjusting certain features of the spray system. These include:

- ☞ nozzle type
- ☞ orifice diameter
- ☞ spray angle
- ☞ nozzle angle
- ☞ travel speed
- ☞ spray pressure
- ☞ operational parameters

### Nozzle type

As described in Chapter 3, many different types of nozzles (*flat fan, cone, solid stream, rotary atomizer, etc.*) are manufactured for pesticide application equipment. Nozzle manufacturers supply nozzle-specific performance information (spray droplet sizes emitted when the nozzle is operated at specified pressures.) In general, solid-stream nozzles produce relatively coarse sprays, as do some low-drift nozzles. Choice of nozzle type is often the most important factor to consider when the intent is to obtain optimum on-target spray coverage while simultaneously minimizing off-target movement of spray (drift.)

### Orifice diameter

In general, spray droplet size increases and *the percentage of the spray volume composed of small droplets decreases* as the diameter of the nozzle orifice increases. Put simply, a bigger hole tends to produce larger droplet. Before installing any new nozzle, the applicator should seek information about droplet spectrums emitted by their nozzle tips-- especially the portion of the spectrum containing droplets having diameters less than 150  $\mu\text{m}$ . From a drift management viewpoint, the typical goal is to minimize (as much as possible) the production of ultra-fine (very small) spray droplets. Nozzles that have relatively large orifice diameters help to accomplish this.

### Spray pattern angle

The included angle formed by the spray emitted from a nozzle is that nozzle's spray pattern angle. Although influenced by spray system pressure, spray pattern angle is largely determined by nozzle design and architecture. In comparison to a wide-angled nozzle of the same orifice size, nozzles designed to form relatively narrow (less than 80°) spray pattern angles and emit non-conical patterns are less prone to produce high drift-risk droplet sizes.

## Nozzle mounting angle

On aerial application equipment, the mounting angle of the nozzles on the spray boom influences spray droplet size. Air shear forces (produced by the aircraft's forward motion) act on the spray being emitted – air shear causes spray droplets to collide with each other and break up. When the nozzles are angled straight back and rearward (oriented in the same direction as the airflow), the air shear available to break up spray droplets is minimized. Thus, the spray droplet spectrum produced at the nozzle tip is least affected (altered) by air shear when the nozzle mounting angle corresponds to airflow direction.

## Travel speed

In general, spray droplet size decreases as equipment travel speed increases. This is because air shear action on spray droplets causes them to break up – producing smaller droplets.

Heightened drift potential due to travel-speed-induced air shear can be a significant issue for aerial application equipment. Many new aircraft used for applying pesticides are easily capable of airspeeds exceeding 120 mph. An aerial applicator applying a pesticide that has a substantial potential for causing drift-related problems should calibrate at, and use, the slowest possible airspeed.

## Spray pressure

The hydraulic pressure (determined by pump output) being exerted on the spray mix at the moment it leaves the nozzle orifice can profoundly influence the nozzle's spray droplet spectrum.

In general, increasing spray pressure simultaneously produces two effects:

- the droplet spectrum shifts (virtually all spray droplets generated become smaller), and
- a larger proportion of the emitted spray becomes drift-prone.

Because of the second reason, **increasing pump pressure (either to enhance target coverage or to "fine-tune" sprayer output) is usually a poor strategy.**

Even though "old" advice on equipment calibration often mentions altering pump pressure as a way to fine tune spray output performance; the fact is, *any such adjustment is very inefficient* -- in order to double (2X) the spray output rate of a given nozzle, pump pressure must be approximately quadrupled (4X increase.) As pressure increases, the likelihood of producing highly-driftable droplets also increases. Instead, it's better to change travel speed. For almost any given set of nozzle tips, altering travel speed usually turns out to be the least risky way to fine-tune on-site sprayer performance.

The best policy is to always follow the nozzle manufacturer's guidelines for recommended spray pressure. All nozzles -- regardless of type -- are designed to operate within a certain pressure range. Nozzle manufacturers well understand the "best" pressure for their product. Using less than the recommended minimum pressure will likely result in poor target coverage. **Using more than their recommended maximum pressure will likely accelerate nozzle tip wear AND produce a greater amount of drift-prone droplet sizes.**

## Operational parameters

This grouping is a “catch-all” category of spray-system-related features that an applicator might potentially manipulate to help manage spray droplet sizes. In most cases, these will either be adjustable features of the emitters themselves, or are factors influencing air turbulence. Examples include:

- rotation rate of rotary atomizers,
- positioning of a CP nozzle’s deflector,
- positioning (orientation) of check valves on the spray boom, and the
- cross sectional shape of the spray boom.

The first two illustrate adjustment features of emitters. As such, they directly influence emitter performance. The latter examples illustrate “configurational features” of a spray system. These will influence the spray droplet spectrum to the extent they affect air turbulence in the vicinity of the spray system’s nozzle tips.

## The Effect of Formulation

A pesticide’s active ingredient is typically combined with other substances to promote effectiveness, handling and usability. The complete pesticide product is referred to as a formulation. Thus, *the term “formulation” describes the form in which the pesticide product is sold.* Examples include dust, granule, wettable powder, flowable, water soluble powder, soluble liquid, emulsifiable concentrate, oil, and others.

Some formulations pose higher intrinsic off-target movement risks than others. For instance, *pesticides formulated as a dust are particularly prone to off-target movement.* Dust particles will often remain airborne longer than 100  $\mu\text{m}$  spray droplets. This is a major reason why dusts are little used today. Because of the well-recognized difficulties of confining dust applications to intended target sites (among other reasons), dusts were not included in the Spray Drift Task Force research efforts – the SDTF database contains only results of liquid application studies.

In general, granules are somewhat less prone to off-target movement than either dusts or sprays. This is because granules are comparatively large particles. They fall to the ground quickly, even when applied in winds up to 10 mph. However, aerial application of a granular formulation can have accompanying off-target pesticide movement -- its main source is the dust-like particles that result from granules rubbing together during product shipping and handling.

Many (most) pesticides are applied as droplets of liquid. In general, liquid formulations either display *water-like properties* or *non-water-like properties*.

Pesticide sprays that display *water-like properties* result from formulations that either:

- ☞ *dissolve* in water (e.g., water-soluble powders, water-soluble liquids, etc.),
- ☞ *physically suspend* in water (e.g., wettable powders, flowables, etc.), or
- ☞ *chemically suspend* in water (e.g., emulsifiable concentrates.)

Most pesticide sprays have *water-like* behaviors. For the vast majority of sprays that have water-like behaviors, the formulation's influence on spray drift potential is not significantly different than the drift potential of water itself -- in other words, spray droplet **SIZE** (rather than chemical composition) is the more important influence. Put another way: *pesticide formulations that yield sprays having water-like properties offer no intrinsic "formulation-built-in-protection" for spray drift. To manage drift potential, their droplet sizes must be controlled.*

A few pesticide products are marketed as liquids that have *non-water-like* behaviors. Typically, these products yield *invert emulsions*. In an invert emulsion, a water-soluble substance is suspended in an oil diluent and oil carrier. The resultant liquid has a thick, creamy, texture. When sprayed, invert emulsions do not readily break up into small droplets in an air stream; nor do they evaporate readily. Therefore, *invert emulsions are not prone to spray drift problems.*

Invert emulsion use is almost exclusively for herbicide treatment of sites where drift would likely cause severe effects on non-target foliage. The very large droplets typically generated by an invert emulsion are ideal for drift control -- and often suitable for herbicide work -- but very large droplets may also dictate higher spray volume rates needed per acre of target site.

## Spray Adjuvants

Spray adjuvants are spray preparation additives that alter the physical characteristics of a liquid as it leaves the nozzle, contacts the target, or both.

Some adjuvants are "surface active agents" (commonly called *surfactants*). These compounds reduce a spray droplet's dynamic surface tension -- the net effect being each droplet landing on target flattens and spreads over a greater area of target surface than would a comparably-sized water droplet. Some surfactants also enhance spray adhesion or treated-surface penetration (or both) -- but the important point is that *most surfactants principally work by reducing dynamic surface tension.*

Adding surfactant to a batch of spray affects either the proportion of the spray emitted as a particular droplet size or, affects the total spray droplet spectrum produced by the nozzle tip, or both. This is because reducing the dynamic surface tension of the liquid promotes small droplet formation. Thus, **without compensating adjustments** (especially: nozzle tip size, travel speed) **surfactant inclusion can increase drift potential.**

Viscosity modifiers (thickening agents) are another type of adjuvant. These compounds give a liquids a "syrup-like" or "stringy" quality and inhibit spray from breaking up into very small droplets. Viscosity-modifying adjuvants are sometimes referred to as *water-soluble polymers* or *viscoelastic agents*.

Viscoelastic agents can be helpful in reducing the production of small drift-prone droplets when used properly. However, high air shear forces (from either travel speed, nozzle angle, pump pressure, etc.), can cancel the anti-drift influence of a viscoelastic agent.

## Tank Mix Composition

The term “tank mix” (sometimes called “spray mix”) – usually indicates multiple active ingredients, multiple formulations, and one or more adjuvants combined with at least one diluent or carrier with the resultant combination being intended for simultaneous application at a single target site.

[Note: A single product diluted according to its label directions for use, although perhaps best termed “*prepared spray*” is frequently called “*spray mix*” as well].

Research efforts of the Spray Drift Task Force (SDTF) involving tank mix effects on driftable spray droplet production indicate that, at least in some cases, tank mixing caused a more measurable effect on liquid atomization (producing small droplets) than did the component active ingredient or product assessed alone. Because of the numerous potential combinations possible in tank mix composition, a definitive all-encompassing general statement about the influence of tank mixing on drift prone droplet production remains unjustified. – for this reason, an applicator is probably best served by being conservative (*i.e.*, using few components) when preparing tank mixes.

## Weather Factors

Every outdoor application of a pesticide spray is affected to some extent by weather conditions -- which includes local area-wide weather events (regional weather), plant-canopy conditions at or near the target site (microweather), and atmospheric conditions -- especially in the atmospheric zone extending upward from just above the target site surface (application zone) to approximately 200 feet of altitude.

Because of weather’s ever-present (often dominant) influence on any spray application’s potential for drift, pesticide applicators need a working knowledge of the principal weather factors that influence spray drift potential. These include:

- wind velocity
- atmospheric stability
- temperature
- relative humidity
- microweather

## Wind Velocity

Wind is the natural movement of air. Velocity is speed combined with *direction* (for example, “5 miles per hour” describes a speed; and, “5 miles per hour, South” describes a velocity.) Because spray drift only occurs downwind, being able to document wind velocity at the target site before and during application should figure prominently in every pesticide applicator’s drift management plan.

Anemometers are devices that measure air movement (some assess air speed; others, air velocity.) Many different kinds of anemometer are available:

- calibrated tubes in which wind lifts a small sphere
- simple pendulum devices, and
- expensive (but accurate) 3-cup rotating types.



Very sophisticated anemometers can simultaneously measure horizontal and vertical components of winds. Normally, only the simpler anemometers are of interest to pesticide applicators. If an anemometer is unable to indicate wind direction, the applicator should also have a magnetic compass on hand. These should be part of every applicator's standard equipment, and should be used together as a matter of routine.

There is **no single correct answer** to the question, "At what minimum wind velocity is spray drift risk too great for spraying to continue?" This is because several factors other than wind velocity should always be considered, including: the tank mix composition of the material being sprayed, the pesticide's label language, the nature of the downwind area adjoining the target site, the spray droplet sizes being emitted by the application equipment, and (of course) the weather conditions at the target site.

## Atmospheric Stability

Measurements of air velocity and atmospheric temperature can be combined to indicate atmospheric stability. **Stable air promotes spray drift.** A relationship called the Stability Ratio (SR) numerically describes atmospheric stability. The SR is often mentioned in literature about drift measurement. The SR is determined by the following equation:

$$SR = \frac{(T_{33} - T_{10}) \times 10^5}{V^2}$$

where:  $T_{33}$  = temperature in C° at 33 feet altitude  
 $T_{10}$  = temperature in C° at 10 feet altitude  
 $V^2$  = average wind velocity between 10 and 33 feet multiplied times itself.  
(NOTE: For the SR equation to work properly,  $V^2$  must be expressed in *cm/sec*. If wind velocity is recorded in *mph*, multiply *mph* by 44.7 to convert *mph* to *cm/sec* before attempting to calculate SR.)  
 $10^5$  = a factor to convert values into easily handled units

### SR Interpretation, CASE I:

When the SR is **1.3 or more**, the atmosphere above the target site is **very stable**. Under such conditions, small spray droplets do not readily dissipate vertically (*i.e.*, they don't fall easily.) Instead, small spray droplets tend to float about in concentrated groups until eventually settling out -- perhaps in quantities sufficient to cause a problem in a non-target area. Case I values indicate the atmospheric condition offers **high risk for spray drift** occurrence.

### SR Interpretation, CASE II:

When a SR value is **between 0.1 and 1.2**, the atmosphere above the target site is **moderately stable**. Case II values indicate the atmospheric condition offers **intermediate risk for spray drift** occurrence.

### SR Interpretation, CASE III:

As the SR value becomes *less than 0.1* (or is a negative value), the atmosphere above the target site becomes increasingly *unstable*. Such conditions are *good for spraying* -- this is because in unstable air, vertical mixing of the air occurs. Vertical mixing helps small droplets dissipate downward. *The smaller the SR number (-1.5 is smaller than -1.0), the greater the likelihood for vertical movement of small droplets and the less the chance for drift-induced damage.* Case III values indicate the atmospheric condition offers **low risk for spray drift occurrence.**

### Stability Ratio (SR), Calculation Example:

An example of target site weather conditions and the procedure for calculating an SR is given below. Follow the example using a pocket calculator.

The temperature at 10 feet is 23.3°C and at 33 feet is 23.0°C. The average wind velocity is 7 mph, blowing due East. (NOTE: multiplying mph by 44.7 converts to cm/sec.)

$$SR = \frac{(T_{33} - T_{10}) \times 10^5}{V^2}$$

$$SR = \frac{(23.0 - 23.3) \times 10^5}{(7 \times 44.7)^2}$$

$$SR = \frac{(-0.30) \times 100,000}{(312.9)^2} = \frac{-30,000}{97,906.41} = -0.31$$

The **negative SR value** describes an **unstable atmosphere** conducive to vertical mixing and *promoting vertical dissipation of small spray droplets, thus it does not increase spray drift risk.* (The atmospheric condition is suitable for spray work.)

## Temperature

In a basic sense, temperature indicates *the amount of thermal energy present in a physical system*. Because energy and work (movement and alteration) are directly related, measurements of temperature provide useful reference points for describing interactions between two or more components in a system. For example, temperature helps describe likely interactions between the atmosphere at a target site and spray droplets. *In general: if temperature increases, the potential for spray drift also increases.* Thus, pesticide application equipment correctly set up for spray work during cool weather is not likely to provide the same degree of spray drift minimization if used “as-is” during hot weather.

Although temperature is certainly important, in most cases, temperature is not a “stand-alone” weather factor in drift management. Instead, temperature is better viewed as a meaningful part of the other weather factors described below (especially see: *relative humidity* and *atmospheric stability*). It’s a “foundation stone.” Its ease of measurement enhances its value.

## Relative Humidity

Relative humidity (RH) indicates the extent a given air sample is saturated by water. RH is temperature dependent (warm air can hold more moisture than cool air) and is expressed as a percentage (of maximum possible saturation.)

RH does *not* significantly influence the loss rate (shrinkage) of petroleum-based spray droplets.

For water-based sprays, the influence of RH on spray drift potential increases as the proportion of small droplets (those with diameters less than 150  $\mu\text{m}$ ) present in a droplet spectrum increases. This is because smaller droplets have higher surface-area-to-volume ratios. The influence of RH on droplet size is most profound when RH values are low (i.e., when RH=50% or less.) This is because ambient RH affects the rate at which water evaporates.

**At low RH, evaporative losses cause spray droplets to reduce size.** Evaporating droplets settle at progressively slower speeds. *The longer a droplet remains airborne the greater its potential to drift.* Spray droplets produced during conditions of high air temperature and low humidity can lose all of their water to evaporation. What remains? Tiny globules of pesticide concentrate -- capable of floating on a breeze for miles. One appropriate management action to reduce the likelihood of this is to apply only medium-sized (200  $\mu\text{m}$ ) or larger droplet sprays whenever local weather conditions are especially hot and dry.

## Microweather

Microweather (*ground-level or within-plant-canopy weather conditions at or near the target site*) affects all outdoor pesticide applications. Microweather temperature and air turbulence especially influences small droplet behavior. These provide further reason for applicators to minimize the production of small (*less than 150  $\mu\text{m}$* ) spray droplets.

The theoretical settling rate of a 50  $\mu\text{m}$  droplet in still air is 15 ft./min. *Upward* air motion many times this velocity is regularly generated by microweather air turbulence. These upward air currents apply greater forces on small droplets than does the downward force of gravity. Under such conditions a small droplet will rise rather than fall. The droplet will remain airborne until the air becomes still and allows the droplet to settle due to gravity. Until it settles, it is at risk of drifting off-target.

In contrast, a 200  $\mu\text{m}$  droplet has a settling velocity (in still air) of 231 ft./min. The upward forces caused by microweather air currents are usually less than the force of gravity acting upon such droplets -- thus, 200  $\mu\text{m}$  droplets are not usually lifted -- instead, they follow a downward path. In result, a very high percentage of such droplets can be expected to deposit on the target site.

**Notes:**

# Spray Drift Management Record

Date: \_\_\_\_\_

Applicator's Name \_\_\_\_\_

Application Target \_\_\_\_\_

Pesticide(s) Applied \_\_\_\_\_

Spray Additive(s) Used \_\_\_\_\_

Application Begin Time \_\_\_\_\_ Application End Time \_\_\_\_\_

Prevailing Wind Speed \_\_\_\_\_ Prevailing Downwind Direction \_\_\_\_\_

Description of Downwind Area \_\_\_\_\_  
\_\_\_\_\_

Temperatures: \_\_\_\_\_ C°      \_\_\_\_\_ C°      Relative Humidity \_\_\_\_\_ %  
(T<sub>10</sub> value)      (T<sub>33</sub> value)

Calculated Stability Ratio Value: ( SR = \_\_\_\_\_ )

Type of Application Equipment: \_\_\_\_\_

Nozzle Description: \_\_\_\_\_

Nozzle-to-Target Distance: \_\_\_\_\_

Pump Pressure: \_\_\_\_\_ Equipment Travel Speed: \_\_\_\_\_

Description of other spray drift management actions: \_\_\_\_\_  
\_\_\_\_\_

# Review Questions for Chapter 4

(Answers: page 194)

01. Spray drift does not occur upwind.

**True**            **False**

{text: Ch 4; p 53}

Comment: \_\_\_\_\_  
\_\_\_\_\_

02. Spray droplet size is the single-most important factor affecting spray drift.

**True**            **False**

{text: Ch 4; p 53}

Comment: \_\_\_\_\_  
\_\_\_\_\_

03. The chief constituents of drifting pesticide spray are droplets having diameters greater than 150 microns.

**True**            **False**

{text: Ch 4; p 54}

Comment: \_\_\_\_\_  
\_\_\_\_\_

04. The fall rate (settling velocity) of a spray droplet is directly proportional to the square of the droplet's diameter.

**True**            **False**

{text: Ch 4; p 55}

Comment: \_\_\_\_\_  
\_\_\_\_\_

## Review Questions for Chapter 4

(Answers: page 194)

05. Under field conditions, large spray droplets can always be expected to fall faster than small spray droplets.

**True**            **False**

{text: Ch 4; p 56}

Comment: \_\_\_\_\_  
\_\_\_\_\_

06. Assuming all other spray system variables (pump pressure, spray mix viscosity, etc.) are kept constant, as nozzle tip orifice diameter increases, the percentage of spray volume composed of small droplets decreases.

**True**            **False**

{text: Ch 4; p 56}

Comment: \_\_\_\_\_  
\_\_\_\_\_

07. In general, solid stream nozzles tend to generate fewer ultra-fine droplets than do fan-pattern nozzles.

**True**            **False**

{text: Ch 4; p 56}

Comment: \_\_\_\_\_  
\_\_\_\_\_

08. From a drift management perspective, 80-degree fan pattern nozzles are less desirable than 120-degree fan pattern nozzles.

**True**            **False**

{text: Ch 4; p 56}

Comment: \_\_\_\_\_  
\_\_\_\_\_

## Review Questions for Chapter 4

(Answers: page 194)

09. The spray droplet spectrum of any nozzle tip is least altered by air shear when its nozzle mounting angle corresponds to airflow direction.

**True**

**False**

{text: Ch 4; p 57}

Comment: \_\_\_\_\_  
\_\_\_\_\_

10. For any given set of nozzles, increasing pump pressure is accompanied by an increase in spray drift potential.

**True**

**False**

{text: Ch 4; p 57}

Comment: \_\_\_\_\_  
\_\_\_\_\_

11. Pesticide formulations that yield sprays having water-like behaviors do not typically provide any built-in protections specifically designed to minimize spray drift potential.

**True**

**False**

{text: Ch 4; p 59}

Comment: \_\_\_\_\_  
\_\_\_\_\_

12. An invert emulsion is a good example of a liquid that does not display water-like behavior.

**True**

**False**

{text: Ch 4; p 59}

Comment: \_\_\_\_\_  
\_\_\_\_\_



## Review Questions for Chapter 4

(Answer: page 194)

13. To an aerial applicator, the biggest advantage of using an invert emulsion is that such products typically improve target site coverage while simultaneously allowing a lower spray volume rate.

**True**            **False**

{text: Ch 4; p 59}

Comment: \_\_\_\_\_  
\_\_\_\_\_

14. Because a surface-active agent (surfactant) reduces a spray droplet's dynamic surface tension, adding surfactant to a batch of spray turns out to be a good way to reduce the drift potential of that spray mix.

**True**            **False**

{text: Ch 4; p 59}

Comment: \_\_\_\_\_  
\_\_\_\_\_

15. Combining multiple formulations and multiple pesticide products in the same batch of spray may or may not adversely affect the drift potential of the resulting spray mix.

**True**            **False**

{text: Ch 4; p 60}

Comment: \_\_\_\_\_  
\_\_\_\_\_

16. Stable air promotes spray drift; unstable air lowers spray drift risk.

**True**            **False**

{text: Ch 4; p 61-62}

Comment: \_\_\_\_\_  
\_\_\_\_\_

## Review Questions for Chapter 4

(Answers: page 194)

17. Generally, the most troublesome aspect of determining the stability ratio (SR) is obtaining an accurate value for the expression  $(T_{33} - T_{10})$ .

**True**

**False**

{text: Ch 4; p 61}

Comment: \_\_\_\_\_  
\_\_\_\_\_

18. In general, as air temperature increases the potential for spray drift also increases.

**True**

**False**

{text: Ch 4; p 63}

Comment: \_\_\_\_\_  
\_\_\_\_\_

19. In general, as relative humidity increases the potential for spray drift also increases.

**True**

**False**

{text: Ch 4; p 63}

Comment: \_\_\_\_\_  
\_\_\_\_\_

20. Because of their rapid settling velocities, a very high percentage of spray droplets having diameters greater than or equal to 200-microns can be expected to deposit on the target site (assuming proper aerial application procedure is followed.).

**True**

**False**

{text: Ch 4; p 64}

Comment: \_\_\_\_\_  
\_\_\_\_\_

# Chapter 5 – Navigation

## Navigation Methods

During aerial application, the pilot must continuously know the aircraft's position relative to the targeted spray treatment site. Put plainly, navigation – the process of determining and maintaining a prescribed and suitable course of travel – is a fundamental part of aerial application work.

Various methods of navigation exist, including:

- landmark navigation – (reliance on absolute position of locale-specific objects)
- dead reckoning – (elapsed time along a rhumb line at estimated constant speed)
- celestial navigation – (reliance on relative position of stellar objects)
- LORAN – (LONG RANGE Navigation [ground-generated hyperbolic radio signal])
- GPS – (Global Positioning System [satellite-generated encoded microwave signal].)

Sole reliance on any of these has attendant drawbacks.

Thus, **landmark navigation** (although an indispensable mainstay of aerial application work) presents problems because manmade landmarks (such as powerlines, structures, roadways, etc) may be moved or altered by storms, property renovation, and so forth. Using a groundflagging crew (a special case of landmark navigation), even when conducted in an absolutely proper fashion, may be *perceived by the general public* as “unsafe” operational procedure. Depending on site conditions, relying on landmark navigation alone can increase the difficulty of flying consistent swaths, ensuring buffer zones are not exceeded, or that in-field skips (or double coverages) are minimized. Drawbacks notwithstanding, *the modern ag pilot must still incorporate landmark navigation practices when flying a spray treatment – even when he or she uses the most modern electronic navigational devices.*

The accuracy of navigating by **dead reckoning** is generally too crude to be of real use for precision aerial spraying applications. The ever-increasing emphasis of spray drift management practices (using buffer zones, etc) typically requires navigational measurement tools that are more refined than those employed for dead reckoning. Moreover, navigational error tends to accumulate quickly when dead reckoning is the basis for navigation.

Although most pilots are familiar with the basic precepts of **celestial navigation**, its use in aerial application work is virtually non-existent. This is mainly because of the obvious dependency on night flight in clear skies. In addition, celestial navigation typically offers insufficient precision for aerial application work demands. It can also entail some rather complex math.

**LORAN** coverage is chiefly coastal. Signal is disturbed in areas where radio-jamming occurs. Nevertheless, LORAN (in various guises, LORAN-C is the current technology) has been in use for almost 60 years – is “tried and true” – and has a record of being continually upgraded. It is frequently cited as a “backup technology” for GPS navigation. In most instances, LORAN-C positioning precision is less exact than that obtained by DGPS.

## **GPS – (Global Positioning System)**

The Global Positioning System is the most modern navigational technology available today. Although fairly new, GPS has rapidly become the predominant means of ascertaining the current position (earth-centered earth-fixed location) of an object. Because of its increasing usage in precision agriculture, aerial application, and related activities; a condensed general discussion of its developmental history, special terminology, how it works, which “version” is available to aerial applicators, and what one might expect in the near future, is offered in the following paragraphs.

### **GPS: Background and Purpose**

On 17 July 1995, the U.S. Air Force declared “full operational capability” of the Global Positioning System (GPS) – a program formally created by the U.S. Department of Defense in 1973. Although various aspects of GPS technology are now readily accessible to millions of people worldwide, the GPS program itself is exclusively funded and managed by the U.S. Department of Defense.

Initially, the intent of the GPS program was to provide a satellite-based system that enabled a U.S. submarine carrying intercontinental ballistic missiles (ICBMs) to surface, rapidly fix its exact position, and promptly launch precisely-targeted weapons. Pin-point targeting of a submarine-launched ICBM is absolutely dependent on knowing the exact location of the missile launch site. Much the same can be said for delivering spray droplets from agricultural aircraft.

### **GPS: Overall System Structure and Function**

Essentially, the Global Positioning System is a satellite-sourced microwave-signal transmission system that can rapidly reference any specific location on earth. Functionally, the GPS system consists of *three major components* (often called *segments*):

- Space Segment — a constellation of 24 earth-orbiting satellites,
- Control Segment — five “on-the-ground” satellite monitoring stations,
- User Segment — individual GPS signal receivers owned and operated by users.

**Space Segment.** Launch of the 24 earth-orbiting GPS satellites [often called Space Vehicles (SV)] began in February 1989 and was completed in June 1993. Each SV is a 1900 pound (in-orbit weight), Rockwell International NAVSTAR Block II satellite that measures 17 feet in diameter (with solar panels extended.) Each satellite maintains an orbital altitude of 10,900 nautical miles and completes one orbit every 12 hours. Every GPS satellite flies in an assigned location in one of six orbital paths. Hence, each

orbital path contains 4 NAVSTAR satellites (6 orbital paths x 4 satellites per path = 24 satellites.) Relative to the earth's surface, the six orbital paths are equidistantly spaced (60 degree intervals.) Relative to the earth's equatorial plane, each orbital path is inclined approximately 55 degrees. Thus, the "constellation" of GPS satellites can be envisioned as having an overall appearance that is remarkably similar to the stylized portrayal of an atomic nucleus (the earth) encircled by a surrounding envelope of orbiting electrons (GPS satellites). An important practical consequence of the GPS satellite constellation is that the overall orbital path arrangement enables a GPS user to simultaneously "view" between five (5) and eight (8) GPS satellites from any point on earth.

**Control Segment.** This component principally consists of five (5) earth-based tracking stations (Hawaii, Ascension Island, Diego Garcia, Kwajalein, and Colorado Springs.) The station at Colorado Springs is the master station. Each tracking station checks the operational health of, and determines precise orbit location data for, its targeted GPS satellites. The master station sends corrections for orbital location and clock data to all satellites. This information enables a satellite to send an up-to-date subset of satellite location and time data to GPS receivers being operated by users.

**User Segment.** The term "*user segment*" refers to the worldwide total of all GPS receivers (governmental, military, and civilian) currently in service and all of the people who are using them (for whatever reasons.)

Enabling precise navigation in three dimensions is a principal purpose of GPS. Hence, navigational receivers are installed and used on seagoing vessels, ground transportation vehicles (trains, trucks, cars, farm equipment, motorcycles, etc.), commercial airliners, general aviation machines, and agricultural aircraft. Some navigational receivers are designed to be worn (or hand-carried) by an individual. GPS navigational receivers vary in size (current GPS receiver units may be as large as a car stereo or as small as a deck of playing cards.)

Because of their nature, GPS-satellite-provided data are proving remarkably useful for many things other than navigation – providing, for example:

- a universal and instantly available global reference for exact (*i.e.*, atomic clock accurate) time,
- a basis for precision map construction,
- a way to precisely measure movements of geological formations,
- the ability to track all of the individuals within an entire fleet of vehicles (such as taxicabs or fire trucks),
- the guidance needed for an aircraft to execute a "center-of-the-runway" landing when local conditions offer zero visibility, or
- the ability of an agricultural aircraft to automatically, near-instantaneously, and continuously regulate its spray boom's output (*gallons-per-minute delivered and boom-on/boom-off operation*) as a function of the aircraft's actual travel speed and position in three-dimensional space.

## How GPS Works

Accurate measurement first requires a precisely-known starting point. For this reason, the master control station (*see* Control Segment) continuously tells each GPS satellite its current location in space – using the center of the earth as an absolute reference point. The satellite processes the location data it receives and uses the result to construct and broadcast a navigational message that states the satellite’s current (earth-fixed, earth-centered) position. The current navigational message is transmitted on microwave frequency. Every 30 seconds, each GPS satellite transmits new components (data frames) of its current navigational message.

Each GPS satellite also continuously emits a unique, complex, electronic signal (pseudo-random code) on microwave frequency. Each satellite regularly repeats (every millisecond) its unique “fingerprint” signal. Signal timing is regulated by the GPS satellite’s on-board atomic clocks. Precise timing is extremely important because GPS receivers rely on *signal travel time* to compute the exact distance between satellite and receiver.

Except for the ultra-precise “P-Code signal” (reserved for military use), every GPS satellite’s current navigational message and carefully-timed “fingerprint” (the C/A signal) can be detected, recognized, and processed by any GPS receiver operated by any user anywhere on (or near) earth.

A user’s GPS receiver uses GPS satellite data to calculate its own current location. In order to find its exact location, a user’s GPS receiver must simultaneously detect the “fingerprint” signals from four (4) different GPS satellites. The signal travel times from three of the GPS satellites form the basis of the GPS receiver’s calculated location in 3-dimensional (X, Y, Z coordinates) space. The signal from the fourth GPS satellite provides a “time-check” verification of the three positional calculations.

## Differential GPS

Worldwide GPS user availability notwithstanding, GPS itself is, first and foremost, intended for U.S. military purposes – both the Space and Control Segments of GPS are exclusively maintained by the U.S Department of Defense. However, each GPS satellite is configured to broadcast its “fingerprint” message on two (2) microwave frequencies. The fingerprint message carried on the one is less robust than that carried on the other. The simpler of the two, the C/A signal, (C/A = coarse acquisition) is made available for non-military GPS uses.

Positional calculations based on the C/A signal cannot yield pin-point precision. The calculated results contain too much uncertainty. In consequence, use of the C/A signal typically gives a location precision of  $\pm 30$  meters (horizontal accuracy.). For some civilian GPS users (for example, ag pilots) this much uncertainty make C/A-signal-based GPS data too coarse for ultra-precise navigation.

Fortunately, modern technology provides a way to reduce the effect of C/A signal data error to a minimum value (typically less than 1 meter, rarely more than 3 meters.) This technology, called *Differential GPS* (often abbreviated DGPS) is the type of GPS most often used by aerial applicators.

Differential GPS utilizes two GPS receivers. One receiver remains stationary at an accurately surveyed location and acts as a reference receiver. The other one is a mobile GPS receiver (for example, mounted in an aircraft.) Both receivers detect C/A-signal GPS satellite data. Both receivers "see" the same GPS satellites. However, the mobile receiver also obtains other data (corrections for GPS satellite timing signals) from the stationary receiver.

Because the stationary receiver's actual location is already precisely known, its incoming GPS satellite timing signals can be analyzed by a local computer that uses the stationary receiver's accurately known position to calculate satellite signal timing (*i.e.*, a sort of "reverse" GPS calculation.) Thus, the stationary receiver's computer figures out what the travel times of the detected GPS satellites' timing signals *should* be, and compares it with what they actually *are*. The existing differences are satellite-specific "timing signal error corrections."

Because the stationary receiver is not absolutely certain which particular GPS satellites the mobile receiver is using, the stationary receiver detects all visible satellites and computes the timing signal error of each. Thereafter, the stationary facility transmits the error corrections to the mobile receiver. It's as if the stationary facility is saying: "*OK everybody, right now the timing signal from satellite #1 is ten nanoseconds delayed, satellite #2 is three nanoseconds advanced, satellite #3 is sixteen nanoseconds delayed...*" *et cetera*. Thus, the mobile DGPS receiver can know how much to adjust each GPS-satellite's timing signal as it's being detected.

The first stationary DGPS receivers were established by private companies whose work demanded high accuracy - oil drillers, surveyors, and so forth. Along with the surveyed reference receiver and its computers, the company would also set up a private communication link to transmit timing signal correction data to its mobile DGPS receivers. In essence, all of today's modern DGPS providers use a similar scheme. **One very important difference between the various modern providers of DGPS correction data is the method by which their data is transmitted to the user's mobile DGPS receiver.** Two transmission methods predominate:

- FM radio tower beacon (*e.g.*, US Coast Guard; NDGPS);
- communication satellite relay (*e.g.*, WAAS; OmniSTAR.)

**Maritime DGPS.** On 15 March 1999, the U.S. Coast Guard declared *full operational capability* of its Maritime DGPS Service. This service consists of two DGPS control centers and about sixty-five (65) DGPS reference stations throughout the United States. Maritime DGPS stations are sited either in coastal areas (Atlantic, Gulf and Pacific), the Great Lakes region, or in areas adjacent the Mississippi River basin. These DGPS reference stations transmit current (real-time) GPS satellite timing signal corrections on U.S. Coast Guard radio beacon frequencies (*i.e.*, 300kHz range). These radio-beacon data are in the public domain (*i.e.*, free of charge.)

Many new GPS receivers are designed to accept and process GPS-satellite timing signal correction

data – and some are equipped with built-in radio receivers. Thus, anyone nearby (*i.e.*, less than 100 miles of a reference station) who has suitable DGPS receiving equipment may receive and use Maritime DGPS satellite correction data for free – and typically expect on-site positioning accuracy of 0.75 meters. For mobile DGPS receivers operating more than 100 miles away from the Maritime DGPS reference station, positioning accuracy decays at a rate of approximately 1 meter per 150 kilometers of distance (1 yard per 90 miles.) Because of this distance-caused decay in accuracy, DGPS users (such as aerial applicators) who require accurate positioning data should always use obtain GPS satellite-signal corrections from the closest possible DGPS reference station. The Maritime DGPS program is now being incorporated into the Nationwide DGPS program (discussed below.)

**Nationwide DGPS.** In October 1997, the U.S. Congress enacted and the President signed *Public Law 105-66*. Section 346 of this law directs the U.S. Dept. of Transportation to work with several government entities and develop and operate a standardized Nationwide DGPS Service. The text of this federal law states that one of its purposes is to provide reliable local-area GPS-satellite timing signal correction data to the general public without user fee (*i.e.*, free of charge.)

The Nationwide DGPS Service program involves the U.S. Air Force, U.S. Coast Guard, U. S. Army Corps of Engineers, National Oceanic and Atmospheric Administration, Federal Highway Administration, and Federal Railroad Administration. Targeted for completion by 2003, the Nationwide DGPS Service expects to then have approximately 80 DGPS radio beacon sites in place throughout the continental United States. The plan is to simultaneously provide every spot in the continental United States with DGPS correction data signals from two land-based radio beacon towers (*i.e.*, double coverage.).

Development of the Nationwide DGPS Service is actively underway. Several Nationwide DGPS Service radio beacon sites now exist. These are similar to Maritime DGPS sites (in fact, the NDGPS Service will ultimately include all US Coast Guard-operated DGPS reference stations.) However, each Nationwide DGPS radio beacon site is different in that its 300-foot tower antenna substantially enhances the effective range available for mobile DGPS user reception. Each Nationwide DGPS Service will provide a radio signal range of 250 miles, and do so at a signal strength that enables 1 meter (or less) DGPS positional accuracy.

Rapid development of the Nationwide DGPS Service is, in part, possible because of the program's focus on refurbishing (and, where necessary, relocating) the U.S. Air Force's recently-mothballed Ground Wave Emergency Network (GWEN) transmission sites. GWEN sites exist throughout the country. GWEN site conversion to a DGPS radio beacon site began in 1999. To date, about twenty GWEN facilities have been converted. These now operate as DGPS radio beacon sites. For areas that lack a GWEN site and need a local DGPS radio beacon site, the U.S. Air Force has agree to relocate old GWEN facilities and help refurbish them for use in the Nationwide DGPS Service.

Single-source radio beacon coverage of DGPS data is projected to be available throughout the entire country by the end of 2001, and double coverage (the program goal – DGPS correction data for any spot in the country simultaneously available from two sources less than 250 miles away) should be a nationwide reality in 2003. For up-to-date information on Nationwide DGPS Service



availability in your local area, contact the nearest office of either the U.S. Coast Gaurd or the U.S. Department of Transportation.

**WAAS.** This acronym identifies the **Wide Area Augmentation System** that has been recently (Sept., 2000) developed by the Federal Aviation Agency (FAA.) The system is mainly intended to supply DGPS data to navigational equipment aboard commercial aircraft making transcontinental flights.

The WAAS utilizes a network of 25 strategically-located receiver stations to gather all GPS space vehicle signals detectable over the United States. Regional subgroups of these receiver stations transfer their data to one of three regional control stations. Each WAAS regional control station computes DGPS correction data and uplinks a correction message to a geosynchronous communication satellite whose signal covers that region of the country. The communication satellite broadcasts the correction message on the same frequency as the S/A signal of GPS (1575.42MHz) to DGPS equipment on board aircraft flying within its broadcast coverage area.

At present, the positional precision of WAAS-mediated navigational signals is  $\pm 7$  meters. This is not likely to improve. In most cases,  $\pm 7$  meters is insufficiently precise to meet the needs of aerial pesticide application work.

The FAA is currently at work on a **Local Area Augmentation System (LAAS)** intended to provide a precision of  $\pm 1$  meter. However, the main purpose of the LAAS is to enable precise navigation in approach paths and other areas immediately adjacent commercial airports. Aerial pesticide applicators are unlikely to find either WAAS or LAAS-mediated signals fully sufficient for precise navigation at a pesticide application target site (unless it happens to be at an airport.)

## **Commercial DGPS Services.**

Commercial DGPS services play a valuable role in making DGPS available to users. For the foreseeable future, commercial DGPS services are likely to continue to fill certain needs – even after Nationwide DGPS is fully operational. The undisputed pioneer (and global dominant) of commercial DGPS services is *OmniSTAR*<sup>®</sup>. The vast majority of DGPS equipment manufacturers (SATLOC, Timble, Ag Leader, CSI, Starlink, Case IH, etc.) make their DGPS receivers OmniSTAR-ready. Because of its dominant market position (and its ability to provide a high degree of location accuracy in near-real-time), a discussion of the OmniSTAR service available in North America follows.

## **OmniSTAR<sup>®</sup>.**

In business since 1987, the North American OmniSTAR<sup>™</sup> DGPS system provides its subscribers with continental coverage and sub-meter accuracy.

The company maintains a network of eleven permanent base stations (10 in the U.S., plus 1 in Mexico). The base stations track all GPS satellites in view and compute corrections for each every 600 milliseconds. Via network wire, each base station sends its corrections to a Network Control Center (NCC) in Houston, Texas. At the control center all of the correction messages are checked, compressed, and uplinked to a geostationary communications satellite. A new uplink occurs every 2 to 3 seconds.

The geostationary satellite (located above the equator on a line due south of El Paso, TX), emits three message beams that together cover all of North America at sufficient power for small

omnidirectional antenna reception. The three beams are arranged to cover the East, Central, and Western portions of North America. All three beams broadcast the same GPS correction data, but the user system must select the proper beam frequency. The three beams have overlaps of several hundred miles. An approximation for the changeover from Eastern to the Central beam would be at a line from Detroit to New Orleans. The Central and Western Beams are divided at a line from Denver to El Paso. Many newer models of GPS receiver automatically select the strongest beam; most older receivers must be manually tuned to the strongest beam. The frequencies of the three geostationary satellite beams are all so similar to that of GPS that a common (single) antenna that receives both GPS satellites' signals and the OmniSTAR satellite's data beams.

Unlike beacon tower differential data (where a user's positional accuracy decreases with range), an OmniSTAR subscriber may use his GPS equipment anywhere within the coverage area and get consistent sub-meter accuracy. This is partly because the OmniSTAR system provides the user with correction data from multiple GPS base stations. Having correction data from multiple base stations substantially helps in reducing a user's GPS signal error. But, there's another reason, too. *The OmniSTAR system includes the location of the subscriber's equipment in the correction data solution.*

Upon being detected, each subscriber receives correction data directly from the OmniSTAR satellite. The incoming data are those generated at each base station. Every base station automatically corrects for errors at its location. But, because the user is not exactly at any of those locations, the correction data are not optimized for that specific user. For the correction data to be optimized for each user, Omnistar must know (learn) the location of the user's receiver.

The need to identify the user's approximate location can be solved by the receiver "reporting" its un-corrected GPS position output to the OmniSTAR system. The approximation only needs to be within several miles of its true position. If an OmniSTAR™ receiver is used, the problem is taken care of automatically. It is wired internally to do exactly that. As mentioned earlier, several other manufacturers of GPS equipment now produce OmniSTAR-compliant receivers.

Given the crude location of the user's receiver, the OmniSTAR system treats the user's receiver as a "Virtual Base Station," –and in result, can automatically optimize its supplied correction data for that particular receiver. It is this technique that enables the OmniSTAR™ user to operate independently and consistently over the entire coverage area without regard to where he is in relation to the base stations. If the optimization step were ignored, user positional errors of as much as ten meters can result.

OmniSTAR currently has five high-powered satellites in use around the world. They provide coverage for most of the world's **land areas**. (OmniSTAR's licensing agreement prohibits its use beyond coastlines of oceans, seas, etc.) User subscriptions are sold by geographic area. A regional OmniSTAR service center sells and activates subscriptions for each area (e.g., North America.)

## **DGPS Consumer Issues**

Any aerial applicator planning to install mobile DGPS hardware and software on his or her aircraft should always ask the product vendor to clarify:

- 1) – What type(s) of signal (e.g., 300 KHz radio beacon, WAAS, L-band OmniSTAR) can your product process for GPS satellite timing signal correction data?

- 2) – What type(s) of DGPS peripheral devices (lightbars, flow controllers, etc.) are compatible with your particular receiver?

## Using DGPS during Aerial Application

Not unsurprisingly, the amount and kind of navigational information that aircraft-mounted DGPS equipment can provide an ag pilot depends on the complexity of the equipment system installed on the aircraft. As with other avionics devices, an FAA certified aircraft maintenance technician must install DGPS equipment components.

DGPS-aided precision aerial swathing is available to any experienced ag pilot flying an aircraft fitted with a “basic” DGPS component set. A basic DGPS component set consists of:

- 1 – *DGPS mobile receiver,*
- 2 – *GPS antenna, and*
- 3 – *a lightbar.*)

### Using the GPS Lightbar

Serving as the pilot’s primary link to the DGPS system during spraying operations, the *lightbar* (a linear array of light-emitting-diodes, or LED’s) enables the pilot to easily visualize local “off-track” error, and promptly make an appropriate flight-path corrections.

The on board DGPS receiver continually sends updated (typically, 5 times per second) signals to the lightbar – causing designated LED’s on the lightbar to illuminate. The pilot interprets the illuminated LED’s as indicators of the aircraft’s current position. The center of the lightbar is configured to correspond to swath centerline. The other LED’s in the array (*i.e.*, those located to the left and right of center) each represent a user-defined ground distance (typically, this ground distance is 2 feet per LED – but can be set to as little as 6 inches per LED.) Typically, the GPS lightbar is mounted in the cockpit at a location inside the pilot’s peripheral vision.

When the DGPS receiver is operating and the aircraft is exactly on line, the lightbar’s three centermost LED’s illuminate. Whenever the aircraft’s path shifts to the left of the swath line, the illuminated sector of the lightbar shifts towards the right. The pilot corrects the flight course by steering toward the illuminated LED’s (*i.e.*, by steering to the right) – flight path correction is achieved when the lightbar’s central LED’s re-illuminate.

When turning or lining up to begin a new swath row, the pilot uses the lightbar to get on course. **Once on correct course** (swath row centerline), **the pilot uses traditional landmark navigation** (*i.e.*, *selecting a distant visual object and flying toward it*) to commence and execute the spray pass.

Especially when making lengthy spray runs, a pilot may find it useful to occasionally check the lightbar’s status – but should **not** do so too frequently. For flight safety’s sake, “keeping your head outside the cockpit” (*i.e.*, not becoming overly-focused on instrument performance) is still the best overall ag aircraft flight plan strategy. GPS can do many things, but it can’t safely fly an ag aircraft – only a competent pilot can do that.

## **Other GPS Equipment Features for Ag Aircraft**

Because positioning data can enhance many aspects of aerial application work, many DGPS equipment manufacturers (Trimble, Satloc, Ag Leader, etc.) also sell system-enhancing on-board computers, spray output controllers and sensors, and computer software packages tailored to link DGPS data to aerial application needs during flight.

A “typical” on-board DGPS computer enables aerial guidance, mapping, waypoint navigation, and spray operation recordkeeping. The pilot uses the computer to select a desired guidance pattern (for example, straight line parallel, racetrack, crop-circle, half-field, squeeze, inverse squeeze, etc.) The on-board computer then utilizes DGPS positioning data to continuously calculate and display aircraft location with respect to the target site and guidance pattern. In result, the need for flagging is eliminated.

In addition, the computer system records the precise in-field location of spray boom operation – thus, for jobs requiring multiple hopperfuls of spray, the mapping system indicates where to begin application of a second (or subsequent) hopperful of spray. Throughout spray operation, the computer system collects data and constructs records for customer billing, environmental reporting, GPS data analysis, and so forth.

Moreover, modern on-board DGPS computer systems offer software programs and computer hardware interfaces that enable precision sprayboom operation. An electronically-regulated flow controller receives continuously-updated ground speed data from the on-board DGPS computer. The computer couples this data with the spray plane’s swath width and uses the result to regulate boom output (gallons per minute). In consequence, the aircraft’s spray system achieves a desired spray volume rate (gallons per acre) for the duration of the job in progress. Feedback data from the boom flow controller is used to construct an on-site record of the sprayboom’s output performance.

Finally, DGPS equipment features for aerial applicators include remote switches that enable the pilot to control the on-board system computer from the joystick.

## **A Cautionary Word**

Like many “hi-tech” areas, DGPS has gained considerable stature in a comparatively short while. It’s hardware and delivery remain fast-changing. None is surprised when “new” becomes re-defined within several months, or after a few seasons. In such an environment, its often poor policy to buy “special deal” DGPS equipment. Remember, when something sounds “too good to be true” – it often is! There’s never anything wrong with checking the competition; but check thoroughly. Often, looking at the “full- featured” products first is a good way to measure the “pulse” of current technology.

## Review Questions for Chapter 5

(Answers: page 195)

01. Modern electronic navigational devices make an aerial applicator's reliance on landmark navigation techniques unnecessary.

**True**      **False**

{text: Ch 5; p 71}

Comment: \_\_\_\_\_  
\_\_\_\_\_

02. In most instances, LORAN-C enables more precise positioning than DGPS.

**True**      **False**

{text: Ch 5; p 72}

Comment: \_\_\_\_\_  
\_\_\_\_\_

03. An important practical consequence of the GPS satellite constellation is that its orbital path configuration enables a GPS user to simultaneously "view" between 5 and 8 satellites from any point on earth.

**True**      **False**

{text: Ch 5; p 73}

Comment: \_\_\_\_\_  
\_\_\_\_\_

04. The reference point of every GPS-derived measurement is the center of the earth.

**True**      **False**

{text: Ch 5; p 72}

Comment: \_\_\_\_\_  
\_\_\_\_\_

## Review Questions for Chapter 5

(Answers: page 195)

05. GPS satellite signals are only available to the general public via for-hire data subscription services.

**True**

**False**

{text: Ch 5; p 76}

Comment: \_\_\_\_\_  
\_\_\_\_\_

06. A GPS receiver uses the travel times of detected GPS satellite signals to compute its (the receiver's) location on earth.

**True**

**False**

{text: Ch 5; p 74}

Comment: \_\_\_\_\_  
\_\_\_\_\_

07. The coarse acquisition (C/A) satellite signal supplied by the GPS system to civilian users is too error-prone for ag pilots to reliably use it "as is" for precise (sub-meter) navigation.

**True**

**False**

{text: Ch 5; p 74}

Comment: \_\_\_\_\_  
\_\_\_\_\_

08. "Differential GPS" (DGPS) refers to a technology that measures and corrects GPS satellite timing signal flaws, and thereafter provides its users with corrected GPS timing signal data.

**True**

**False**

{text: Ch 5; p 75}

Comment: \_\_\_\_\_  
\_\_\_\_\_

## Review Questions for Chapter 5

(Answers: page 195)

09. Unless an individual (or company) installs and operates his own private DGPS reference station, DGPS correction data are only available from subscription services.

True

False

{text: Ch 5; p 76}

Comment: \_\_\_\_\_  
\_\_\_\_\_

10. DGPS correction data are transmitted to users from fixed FM beacon towers or via communication satellite relay (uplink/downlink.)

True

False

{text: Ch 5; p 75}

Comment: \_\_\_\_\_  
\_\_\_\_\_

11. The Wide Area Augmentation System (WAAS) developed by the Federal Aviation Agency (FAA) for aircraft navigation adequately meets (or exceeds) the navigational needs of most aerial applicators.

True

False

{text: Ch 5; p 77}

Comment: \_\_\_\_\_  
\_\_\_\_\_

12. Regarding data quality and resultant positional accuracy, very little actual difference exists between WAAS transponders, Coast Guard beacons, or OmniSTAR satellite signals.

True

False

{text: Ch 5; p 75-78}

Comment: \_\_\_\_\_  
\_\_\_\_\_

## Review Questions for Chapter 5

(Answers: page 195)

13. The “basic set” DGPS components needed in an agricultural aircraft consists of a mobile DGPS receiver and an antenna.

**True**

**False**

{text: Ch 5; p 79}

Comment: \_\_\_\_\_  
\_\_\_\_\_

14. For flight safety’s sake, a GPS lightbar should never be mounted in an ag aircraft’s cockpit.

**True**

**False**

{text: Ch 5; p 79}

Comment: \_\_\_\_\_  
\_\_\_\_\_

15. Use of a GPS lightbar enables a pilot to discontinue landmark navigation practices, increase positional accuracy during flight, and maximize flight safety.

**True**

**False**

{text: Ch 5; p 79}

Comment: \_\_\_\_\_  
\_\_\_\_\_

16. Utilizing DGPS equipment aboard an ag aircraft can completely eliminate the need for either manual flagging or mechanical swath marking devices.

**True**

**False**

{text: Ch 5; p 80}

Comment: \_\_\_\_\_  
\_\_\_\_\_



## Chapter 6 - Calculating the Area of a Target Site

### Introduction

Target site size (area) influences both how much pesticide product and how many gallons of spray mix are needed for a job. Knowing these things "ahead of time" is the best way to avoid the problem of excess or "left over" spray mix.

The area of a given target site is always determined by multiplying measurements of US Distance. Before being multiplied, *the measurements must be expressed in the same unit.* The most common unit used to measure distance is the "foot." *When one foot of length is multiplied by one foot of width, the result is one square foot.*

In arithmetical form, this is represented as:

$$(1 \text{ foot of length}) \times (1 \text{ foot of width}) = 1 \text{ square foot of Area}$$

The square foot (*sq. ft.*) is the basic unit of US Area Measure. In most cases, the square footage of a site is calculated first. Other units of area (Acres, Hectares, etc..) are determined by using conversion factors after square footage is known. The situations discussed below calculate square footage only.

### Regularly-shaped Areas

#### Rectangular Sites:

To calculate the area of a rectangular site, you must know:

- the **length** of the rectangle, and
- and **width** of the rectangle.

Before doing any arithmetic, make sure that *both dimensions* are expressed in the same units (for example, *length and width are both expressed in feet*).

To find the area (in square feet) *multiply length by width*.

**Example:**

A rectangular field is 250 feet wide and 800 feet long. What is the area of the field (in square feet)?

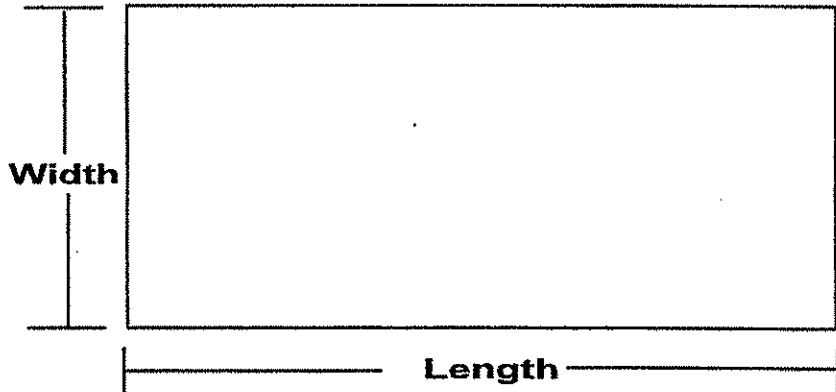

**Solution:**

**Step 1:** Express both dimensions (length and width) in feet. If either (or both) are not known in feet, convert them to feet.

$$\text{length} = 800 \text{ feet}$$

$$\text{width} = 250 \text{ feet}$$

**Step 2:** Calculate the area of the rectangle by *multiplying length times width*.

$$(\text{length of rectangle in feet}) \times (\text{width of rectangle in feet}) = \text{area (sq. ft.)}$$

$$(800 \text{ feet}) \times (250 \text{ feet}) = 200,000 \text{ sq. ft.}$$

**NOTE:** To convert the 200,000 square feet to *Acres*, divide the square footage of the field by the number of square feet contained in one acre (43,560 sq.ft./Acre).

## Circular Sites:

To calculate the area of a circular site, you must know two values:

- the **radius** of the circle, and
- and the value of a constant: **pi** (often indicated by the Greek letter: " $\pi$ ").

**Q.** What is a *radius*?

**A.** *A radius is the length of the straight-line distance from the center of a circle to any given place on the circle's edge. The radius is equal to one half of a diameter.*

**Q.** What is a *diameter*?

**A.** *A diameter is the length of the longest possible straight-line distance across a circle. Any such straight line passes through the center of the circle.*

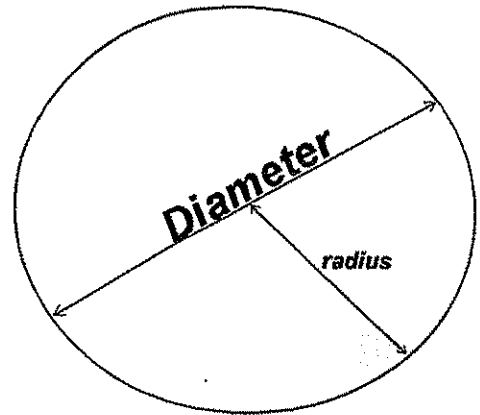

**Q.** What is *pi* ( $\pi$ )?

**A.** Pi is a ratio (stating the number of diameters present in a circumference) discovered by ancient mathematicians. It is used to determine areas or volumes that involve circles, spheres, and other curved objects. Pi is represented by the Greek letter " $\pi$ ."

When doing pesticide arithmetic, use the following value for  $\pi$ :

$$\pi = 3.14$$

The area of any circle is determined by multiplying *pi* ( $\pi$ ) times the *square of the radius* of the circle, where "the square of the radius" means *the length of the radius multiplied by the length of the radius*.

Before doing any arithmetic, make sure the length of the radius (or the diameter) is known in feet. *If only the diameter is known, calculate the radius by dividing the diameter by two.*

$$\frac{\text{length of the diameter in feet}}{2} = \text{length of the radius in feet}$$

Then, to calculate the area of the circle (in square feet) *multiply the length of the radius times the length of the radius by " $\pi$ ."*

$$(\pi) \times (\text{length of the radius in ft.}) \times (\text{length of the radius in ft.}) = \text{area of circle in sq. ft.}$$

**Example:**

Measurement of a circular field shows the field has a diameter of 400 feet. What is the area of the field (in square feet)?

**Solution:**

**Step 1:** Find the radius of the circle. To do this, *divide the length of the diameter by two.*

$$\frac{\text{length of the diameter in feet}}{2} = \text{length of the radius in feet}$$

$$\frac{400 \text{ feet}}{2} = 200 \text{ feet}$$

**Step 2:** Calculate the area of the circle by *multiplying the length of the radius, times itself, by the value for pi.*

$(\pi) \times (\text{length of the radius in ft.}) \times (\text{length of the radius in ft.}) = \text{area of circle in sq. ft.}$

$(3.14) \times (200 \text{ feet}) \times (200 \text{ feet}) = \text{area of the circle in sq. ft.}$

$(3.14) \times (200 \times 200) \text{ sq. ft.} = \text{area of the circle in sq. ft.}$

$(3.14 \times 40,000) \text{ sq. ft.} = 125,600 \text{ sq. ft.}$

**NOTE:** To convert the 125,600 square feet to *acres*, divide the square footage of the circular field by the number of square feet contained in one acre (43,560 sq.ft./Acre.)

## Triangular Sites

To calculate the area of a triangular site, you must know two dimensions:

- the **length** of the triangle's longest side (*i.e.*, its **BASE**), and
- and the **width** of the triangle at its widest point (*i.e.*, its **HEIGHT**).

Before doing any arithmetic, make sure that *both dimensions* are in the same units (for example, *both the length and the width are in feet*).

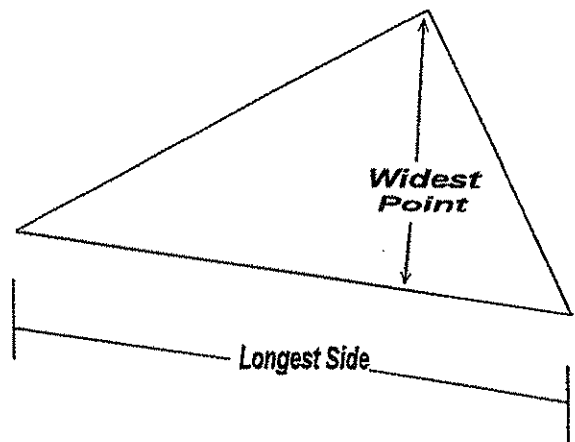

To find the area of any triangle, *multiply the length of the triangle's longest side by the width of its widest point, and then divide by two.* Arithmetically, this is indicated as:

$$\frac{(\text{length of longest side in ft.}) \times (\text{width at widest point in ft.})}{2} = \text{area of triangle in sq. ft.}$$

**Example:**

A triangular field measures 300 feet wide at its widest point and 650 feet along its longest side. How many square feet does this triangular field contain?

**Solution:**

**Step 1:** Make sure that both dimensions (length and width) are stated in feet. If either (or both) are not given in feet, convert them to feet.

length along the triangle's longest side = 650 feet  
width at triangle's widest point = 300 feet

**Step 2:** Calculate the area of the triangle by *multiplying the length times the width and then dividing by two.*

$$\frac{(\text{length of longest side in ft.}) \times (\text{width at widest point in ft.})}{2} = \text{area of triangle in sq. ft.}$$

$$\frac{(650 \text{ feet}) \times (300 \text{ feet})}{2} = \text{area of triangle in sq. ft.}$$

$$\frac{(650 \times 300) \text{ sq. ft.}}{2} = \text{area of the triangular field in sq. ft.}$$

$$\frac{(195,000) \text{ sq. ft.}}{2} = 97,500 \text{ sq. ft. in the triangular field}$$

**NOTE:** To convert the 97,500 square feet to acres, divide the square footage of the triangular field by the number of square feet contained in one acre.

### Irregularly-shaped Sites

Many sites are not perfect circles, rectangles or triangles. Often, agricultural sites have curved "corners", have a bulge along one or more sides, or, have a notched or "missed" portion because an obstacle doesn't allow cultivation or spraying. *In such cases, use your judgement to decide the best way to go about calculating the amount of square footage present.* Here are some guidelines on how to proceed.

**Step 1:** Draw a general map of the site. *This is the most important step.* In most cases, you do not need very many measurements to make a good general map. *The main purpose of the map is to let you clearly identify the number and kinds of "basic shapes" that together constitute the site.*

For example, a general map of an irregularly shaped site might look like this:

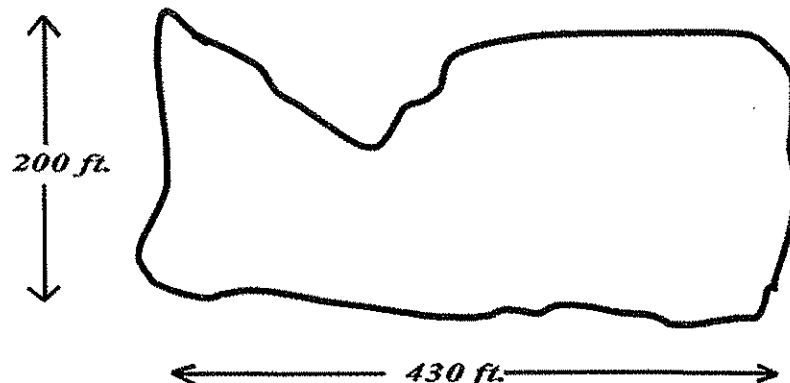

- Step 2:** Identify the kinds and number of regularly-shaped (triangles, circles, rectangles) subsections that together constitute the irregular site. Then, return to the field and place marker stakes to identify the boundaries (or corners) of each subsection. Record the location of each marker stake on your general map.
- Step 3:** Make in-field measurements and determine the dimensions of each regularly shaped subsection. Record these measurements on your general map.
- Step 4:** Calculate the area (in square feet) of each regularly-shaped subsection. To do this, follow the procedures for calculating the area of a rectangle, circle, or triangle.
- Step 5:** Sum the individual square footages (i.e., the areas that you've calculated for each of the regularly shaped subsections). *The sum of the subsectional areas equals the total area of the irregularly shaped site.*

**Example:**

A general map of an irregularly shaped field shows that the site appears as follows:



What is the square footage of this irregularly shaped site?



**Solution:**

**Step 1:** Based on the general map of the site, three regularly shaped subsections (two triangles and one rectangle) can be identified and measured. The boundaries of these are indicated by broken lines in the figure below.

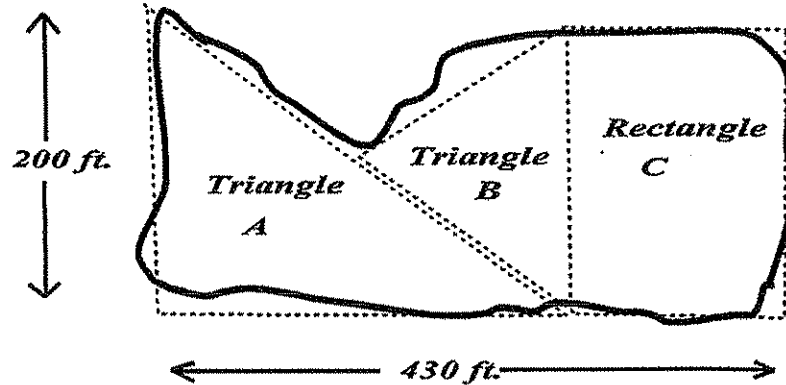

**Step 2:** In-field measurements determined that the three subsections have the following dimensions:

**Triangle A:**

length of longest side = 360 feet  
width at widest point = 240 feet

**Triangle B:**

length of longest side = 200 feet  
width at widest point = 140 feet

**Rectangle C:**

length = 200 feet  
width = 130 feet

**Step 3:** Calculating the area (in square feet) for each of the three subsections reveals:

**Area of Triangle A:**

$$\frac{(360 \text{ ft.}) \times (240 \text{ ft.})}{2} = 43,200 \text{ sq. ft.}$$

**Area of Triangle B:**

$$\frac{(200 \text{ ft.}) \times (140 \text{ ft.})}{2} = 14,000 \text{ sq. ft.}$$

**Area of Rectangle C:**

$$(200 \text{ ft.}) \times (130 \text{ ft.}) = 26,000 \text{ sq. ft.}$$

**Step 4:** Thus, the total area of the irregularly shaped site is:

$$(\text{area of triangle A}) + (\text{area of triangle B}) + (\text{area of rectangle C}) = \text{total area}$$

$$(43,200 \text{ sq. ft.}) + (14,000 \text{ sq. ft.}) + (26,000 \text{ sq. ft.}) = 83,200 \text{ sq. ft.}$$

## Review Questions for Chapter 6

(Answers: page 195)

01. How do you calculate the area of a rectangle?

A.

{text: Ch 6; p 86}

02. How many acres are present in a circular site whose diameter measures 0.4 miles?

A.

{text: Ch 6; p 87-89}

*radius* =

*area* =

*Acreage* =

03. How many acres are present in a triangular site that measures 990 feet along its longest side and measures 670 feet across its widest point?

A.

{text: Ch 6; p 89-91}

*Area* =

*Acreage* =

## Notes

---

## Chapter 7 - Calibration Procedures

Aerially applied agricultural pesticide products, either liquid or dry, must be applied uniformly at the proper amount per acre of target site. The proper amount per acre of target site can be (and typically is) influenced by agricultural research findings, grower experience, the target pest, and crop growth stage -- *but in all cases, the target site must be specified by the pesticide label and the application rate per acre must fully accord with the pesticide product label's directions for use.* To do otherwise violates both federal and state law.

### Initial Factors

In choosing either the amount of active ingredient applied per acre, the amount of formulated pesticide product (either of these may be termed the "label rate") or the amount of diluted spray mix applied per acre (properly termed the "spray volume rate"), an aerial applicator **may not exceed** the upper bound of any range of rates (label or spray volume) specified by the pesticide label. *An application at less than label rate may be legally applied only if the owner of the crop gives his or her express consent for the reduced rate beforehand, and all other label language directions are fully complied with.*

Often, a pesticide label indicates a range of label rates and spray volume rates (e.g., "...apply 1.5 pint of 'Product XYZ' in 5-15 gallons of water per acre.") Within the stated spray volume rate range (5-15 gpa), selecting an appropriate gallons per acre of diluted spray is influenced by target pest biology, pesticide product chemistry, crop growth stage, ambient weather conditions, and spray drift management considerations. For example, the need to reduce spray drift might dictate larger spray droplets – and because target site spray coverage is inversely proportional to droplet size; a spray treatment that uses the higher end of the spray volume rate range (15 gpa) might be needed in order to obtain adequate target site coverage.

After the desired spray volume rate (gpa) has been decided, the aerial applicator must determine a suitable combination of two independent factors:

### Independent Factor # 1: Boom discharge rate

- the rate at which the spray mix is discharged from the spray boom; expressed in:
  - gallons per minute (*gpm*).

**NOTE:** Three variables influence boom discharge rate (*gpm*):

- nozzle tip size
- total number of working nozzles on the boom
- at-nozzle spray pressure (*i.e., pump pressure*)

## Independent Factor # 2: Treatment progress rate

- the amount of target site area treated per unit of flight time; expressed in:
  - acres per minute (*apm*).

**NOTE:** Two variables influence the treatment progress rate (*apm*):

- swath width
- speed of the aircraft as it passes over the target site.

### Altering Nozzle Configuration

Changing the nozzling (size, number and arrangement) of the spray boom is usually the most efficient way to make large alterations in an ag aircraft's boom output rate. However, because several other factors also influence the spray system's overall performance, selection of new nozzle tips requires some initial estimations be made. (Without nozzles, the spray system's actual effective swath width is not knowable -- it must be estimated.) Only after new nozzle tips are installed can effective swath width be determined by spray pattern testing.

Similarly, the pesticide labeling will indicate a spray volume rate (usually as a range of values). But, because a spray volume rate is expressed in gallons per acre (*gpa*), such information cannot be used "as is." This is because nozzle tip performance is characterized by a flow rate expressed in gallons per minute (*gpm*).

To reconcile the difference in measurement units, aircraft productivity at the target site (the treatment progress rate) needs to be considered. Treatment progress at the target site is measured in acres per minute (*apm*.) Coming full circle: to determine *apm*, one must know effective swath width.

Thus, in order to alter nozzle configuration, you must:

- decide on a desired spray volume rate (*gpa*);
- decide on an airspeed (*mph*)
- decide on a pump pressure (*psi*);
- you must also estimate the aircraft's effective swath width (ft.)

Finally, you must decide your objective. Do want to:

- ◆ Select a **nozzle tip size**? (If so, total number of nozzles on the boom must be known.)
- ◆ Determine the **number of nozzles** to use? (If so, nozzle tip size must be known.)

Before addressing either objective, first perform the following two steps:

**Step 1:** Use your estimated swath width and desired airspeed to calculate a treatment progress rate, expressed in acres per minute (*apm*):

$$\text{Acres Treated per Minute}_{\text{estimated}} = \frac{[\text{Swath Width (ft)}] \times [\text{Airspeed (mph)}]}{495}$$

**Example:** (When swath width is estimated to be 50 feet and desired airspeed is 105 mph.)

$$\text{Acres per Minute}_{\text{estimated}} = \frac{(50 \text{ ft}) \times (105 \text{ mph})}{495}$$

$$= 10.606 \text{ acres per minute}$$

**Step 2:** Determine the boom output rate (gallons per minute) that must be obtained in order to provide the spray volume rate (gallons per acre) chosen for the target site. To do this, multiply the treatment progress rate (*apm*) by the desired spray volume rate (*gpa*).

$$\text{Boom Output Rate}_{(\text{gal. per minute})} = (\text{Acres per Minute}) \times (\text{Spray Volume Desired})_{(\text{gal. per acre})}$$

**Example:** (When the treatment progress rate is 10.606 *apm* and desired spray volume rate = 7.5 *gpa*.)

$$\text{Boom Output Rate}_{\text{needed}} = (10.606 \text{ apm}) \times (7.5 \text{ gpa})$$

$$= 79.545 \text{ gallons per minute}$$

## Selecting Nozzle Tip Size

In order to select a suitable nozzle tip size, *the total number of nozzles to be installed on the boom must be decided beforehand*. Thereafter, dividing the boom output rate (calculated in Step 2 above) by the number of nozzles on the boom yields the per-nozzle flow rate (gpm) that you should seek in a nozzle manufacturer's nozzle tip selection chart. This is expressed mathematically as:

$$\textit{Desired Flow Rate per Nozzle} = \frac{\textit{Boom Output Rate (gpm)}}{\textit{Number of Nozzles on Boom}}$$

**Example:** (Assuming 58 nozzles will be installed on the boom.)

$$\textit{Desired Flow Rate per Nozzle} = \frac{79.545 \textit{ gallons per minute}}{58 \textit{ nozzles}}$$

$$\textit{Desired Flow Rate per Nozzle} = 1.37 \textit{ gallons per minute}$$

Thus, in a nozzle selection chart, you should look for a nozzle tip rated to deliver **1.37 gpm** at the pump pressure you intend to use.



## Determining Total Nozzles Needed

To determine the total number of nozzles needed on a boom, *flow rate per nozzle (in gallons per minute) must be known beforehand*. Thereafter, dividing boom output rate (calculated in Step 2 above) by flow rate per nozzle (gpm) yields the number of nozzles needed on the boom. This is expressed mathematically as:

**Example:** (Assuming nozzle flow rate is 1.65 gallons per minute.)

$$\text{Total Number of Nozzles Needed on Boom} = \frac{79.545 \text{ gallons per minute}}{1.65 \text{ gallons per minute}}$$

$$\text{Total Number of Nozzles Needed on Boom} = 48.209 \text{ nozzles}$$

Thus, a spray plane being set up to deliver 80 gpm, when using nozzles rated to deliver 1.65 gpm (per nozzle) will require 48 such nozzles installed on the boom.

## Swath Width

Before an ag aircraft can be completely calibrated, its swath width must be determined. An ag plane's swath width is measured by pattern testing. A pattern test must be conducted whenever the dispersal system (spray boom or ram air spreader) is altered in any fashion.

## Pattern Testing a Spray Boom

When evaluating the spray pattern and determining the effective swath of an aircraft, spray height, speed, power setting, spray pressure, and nozzle location should duplicate field conditions. The best time for spray pattern testing is early in the morning before the sun heats the ground and causes thermal turbulence. During testing, the plane should be flown directly into the wind. Conduct pattern test flights only when ambient wind speed is less than 10 mph.

Modern equipment for spray pattern testing consists of a detector that reads the intensity of fluorescent dye deposited on a string positioned across a target site. Following a spraying pass made by the aircraft being evaluated, the string is scanned and the deposition of dye-containing spray is measured and recorded by computer. The computer analysis yields a graphical image of actual spray pattern. The computer printout is interpreted to assess nozzle positioning along the boom, spray deposition uniformity, and the aircraft's effective swath width.

The NAAA has purchased a number of the spray pattern analyzing computers and offers them to State Agricultural Aviation Associations for holding fly-ins where aerial applicators can evaluate the spray patterns of their aircraft. Typically, fly-ins are open to both Association members and non-members alike.

If computerized pattern testing equipment is not readily available, an applicator can independently assess the spray pattern being applied by his aircraft. A suitable test layout for spray pattern evaluation is depicted in Figure 11. A linear sample array (a sample line) can be made by stapling paper cards to small blocks of wood, and arranging these in a sample line. The length of the sample line should be at least 80 feet -- and preferably 100 feet.

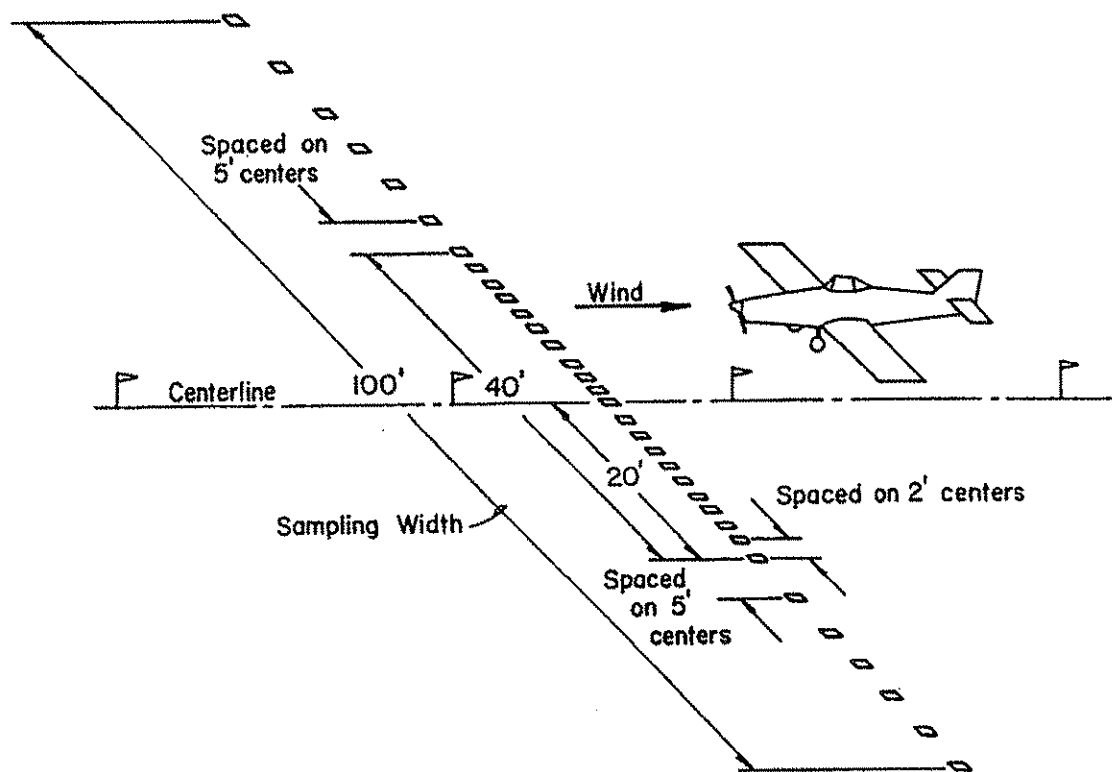

Figure 11. Pattern evaluation layout

Before flying any spray pattern test, make sure the nozzle tips, screens, and check valves are clean. Put about 30 gallons of water into the spray tank and add enough water soluble dye to make a dark solution. Before takeoff, operate the pump, briefly engage the boom and check for leaks. The dye will make spray system leaks or plugged drop pipes easy to spot. Determine the wind direction and place flags about 100 yards on each side of the sample line.

After takeoff, purge the boom and make sure that dye leaves the end nozzles. Align the aircraft with the flags on a spray run that duplicates actual field application. Operate the boom for at least 100 yards both before and after treating the sample line. To minimize control-surface-induced air disturbance, maintain straight and level flight during spray boom operation – this will help assure a representative pattern. After the pass, collect the sprayed cards (keeping them in order) replace the cards with clean ones, and repeat the test to make sure the run was representative of typical spray deposition.

Visual evaluation of treated cards requires practice, but common problems with spray uniformity and swath width can usually be detected. Especially look for:

- a region of light spray density in the vicinity of the flight centerline
- uneven spray densities toward the wingtips.

Effective swath width is less than the distance between the outmost cards where dye is evident. Figure 12 simulates a graphical plot of a spray pattern test result. The amount of dye per card is reasonably constant for some distance on each side of the centerline path and then gradually diminishes until no dye is evident. The effective swath is the distance between the midpoints on the sloping ends of the pattern. Each midpoint corresponds to a dye deposition (per card) that is approximately one-half the “average” amount of spray deposited in the more “uniform” portion of the spray pattern.

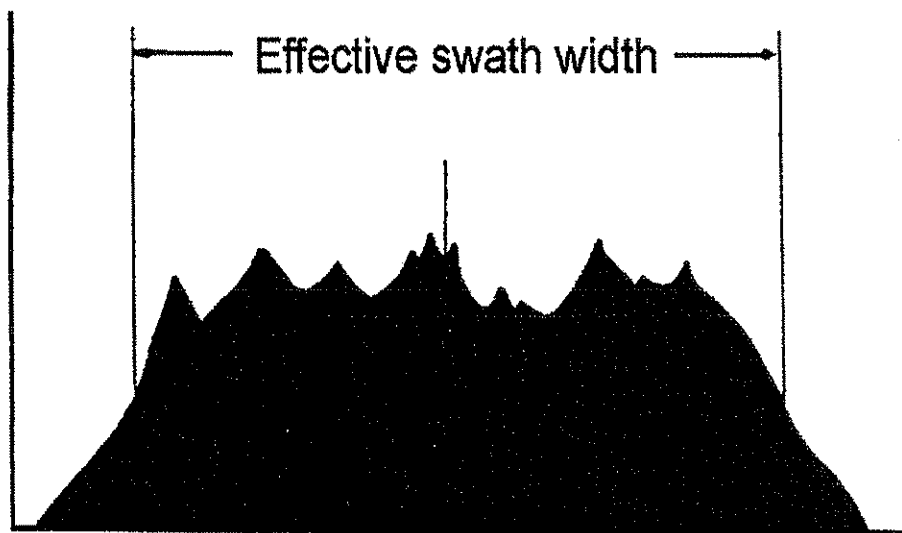

Figure 12. Effective swath of a typical pattern

Typical problems that spray pattern testing can help detect include:

- **Leaks** - Sometimes operators are unaware of system leaks. Having dye in the spray mix facilitates spray system leak detection. If, for example, very large drops of dye are found on the paper used for pattern evaluation, the spray system should be thoroughly checked for leaking components.
- **Nozzle problems** - Finding both large and small spray droplets on the sampling paper when pattern testing is normal. This is because all nozzle types actually generate a range of droplet sizes. However, if average spray droplet size varies tremendously between locations in the pattern, the operator should either suspect different size nozzles, badly worn nozzle tips, or both.
- **Incorrect droplet spectrum** - Strictly speaking, measurement of droplet stains on the sampling paper will not precisely determine the size of droplets being generated by a given set of nozzle tips. However, an operator can roughly ascertain whether the spray droplets being produced are, in general, suited for the job to be done. Generally, coarse droplets are best suited for herbicide applications, small to medium droplets sprays are best suited for insecticide sprays, and very small droplets are best for fungicide applications.
- **Propwash displacement** - On fixed-wing aircraft, propeller rotation produces a spiral slipstream about the fuselage. This spiral slipstream moves spray particles from right to left under the aircraft. The result is reduced application rate under the right wing and higher application rate under the left wing. Figure 13 shows a typical flawed spray pattern created by propwash effect. This problem is most evident on aircraft fitted with spray booms that have symmetrical nozzle arrangement.

The conventional correction for propwash displacement is to add nozzles to the right side of the boom and remove nozzles from the left side of the boom. The number and location of the nozzles to be altered is determined by trial and error. Generally the nozzles that need alteration are those positioned within 3-6 feet of the fuselage.

- **Propwash Overcompensation** - Spray pattern distortion due to propwash has been emphasized so much that some operators actually overcompensate for propeller-induced effects. The resulting pattern is shown in Figure 13 (center image). Often, a pronounced spray peak developing on the left of the fuselage can be corrected by turning off one or more nozzles mounted adjacent (within 3-6 feet) the right side of the fuselage.
- **Wingtip Vortex** - Wingtip vortex is generally characterized by a pattern with high peaks at its edges (Figure 13 -- lower image.) The pattern can occur on either fixed or rotary wing aircraft. Spray emitted from the boom's outermost nozzle tips is captured by the wing tip (or rotor) vortex and propelled upward. Spray droplets so captured do not contribute to the effective swath width – but are a significant source of spray drift droplets. In almost every case, wingtip-vortex-induced spray pattern problems can be

overcome by ensuring spray boom length does not exceed 70% of wingspan (or 80% of rotor span.)

- **Rotor Distortion** - Rotary wing aircraft may display a spray pattern that supplies a low application rate in the middle and high peaks at each end of the spray boom. Normally, this is corrected by adding nozzles under the aircraft between the skids.

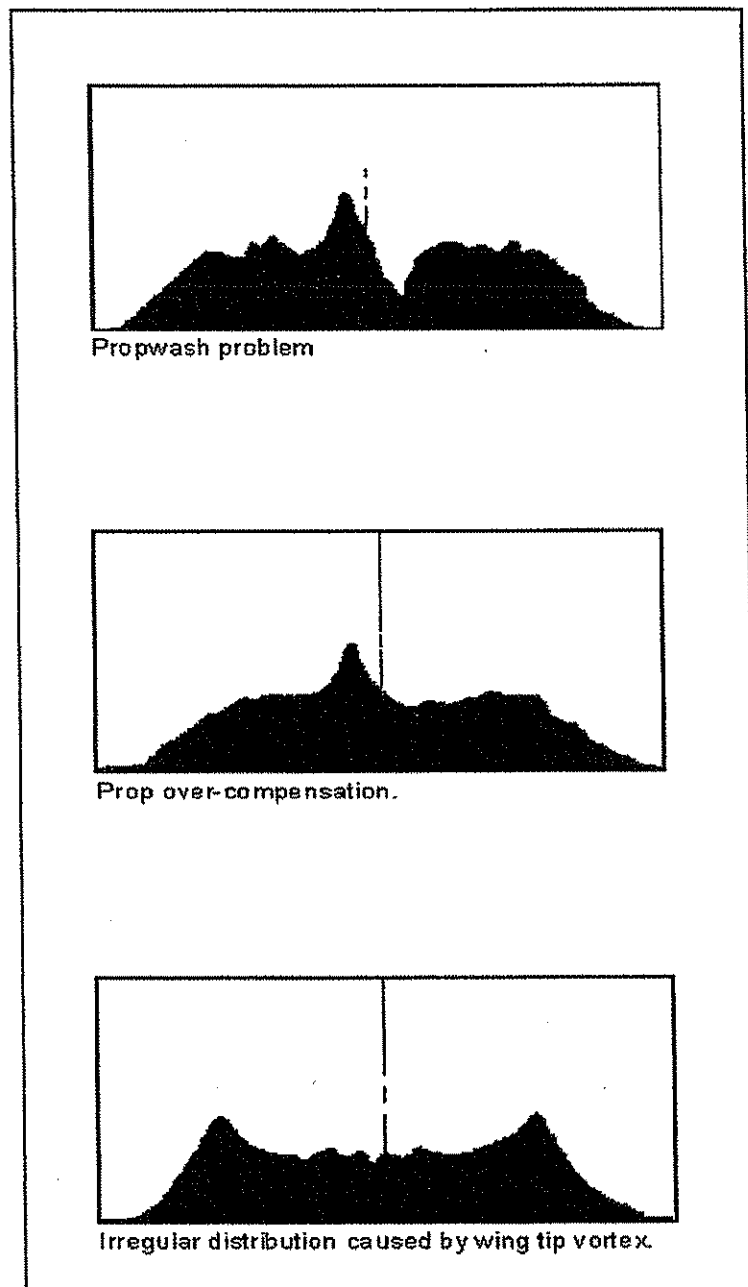

Figure 13

## Pattern Testing a Ram-Air Spreader

Place a series of at least 13 collection pans at 5-foot intervals in a straight line on the ground across the flight line. The footprint shape of the collection pans is unimportant, but the pans should be approximately 4 inches deep, have an area of at least 1 square foot, and the inside should be padded with a thin layer of foam. All of the collection pans should be the *same size*.

Follow the manufacturer's guidelines and set the ram-air spreader gate to the desired rate per acre. Fly a swath test centerline oriented at a right angle to the line of collection pans. If ambient wind speed is greater than 8 mph (sustained), orient the line of pans at a right angle to the prevailing wind. Fly directly into the wind.

After the swath test flight, collect the granules from each pan from left to right into a graduated cylinder with a diameter of no more than 1/4 inch. Record the quantity of granules from each pan on a graph in the exact order of collection from left to right. When plotted on paper, as in Figure 14, an interpretable chart of the volume distribution of granules across the swath is obtained.

## Determining Swath Width

The distribution shown is an idealized plotting of the amounts caught in 13 pans laid out across 60 feet. This triangle is a perfect pattern for a 30 feet swath spacing. Another pattern centered 30 feet to the right of the first flight path would result in an even distribution between the two patterns

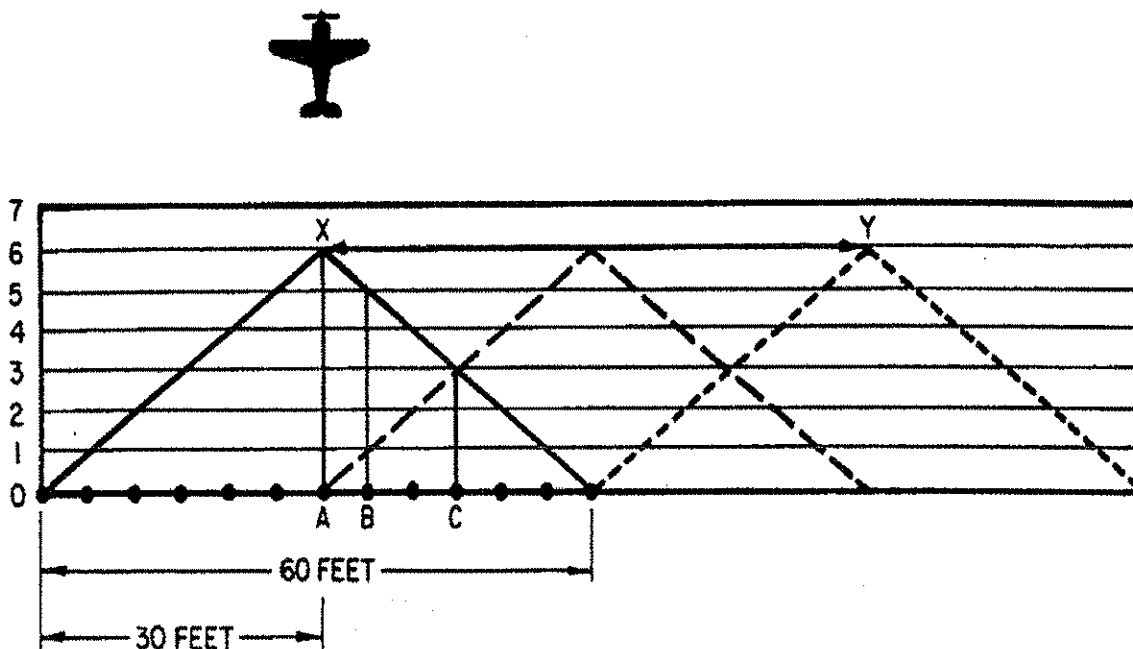

Figure 14. Plot of dry material across the swath.

Figure 14 shows that at point A, six units (pounds, ounces, or any other unit of weight) were applied to the ground. At point B, five units were applied by the first swath and one by the second swath for a total of six. At point C, three units were applied by each swath for a total of six. Therefore, an even application can result from a spreader supplying a triangular-shaped pattern by using half of the width of the pattern as the swath spacing.

The pattern shown in Figure 15 is a common pattern generated by granular spreaders. This pattern is trapezoidal. The effective swath width of a pattern having this shape is determined by solving the equation:

$$\text{effective swath width}_{\text{trapezoidal pattern}} = \frac{AD + BC}{2}$$

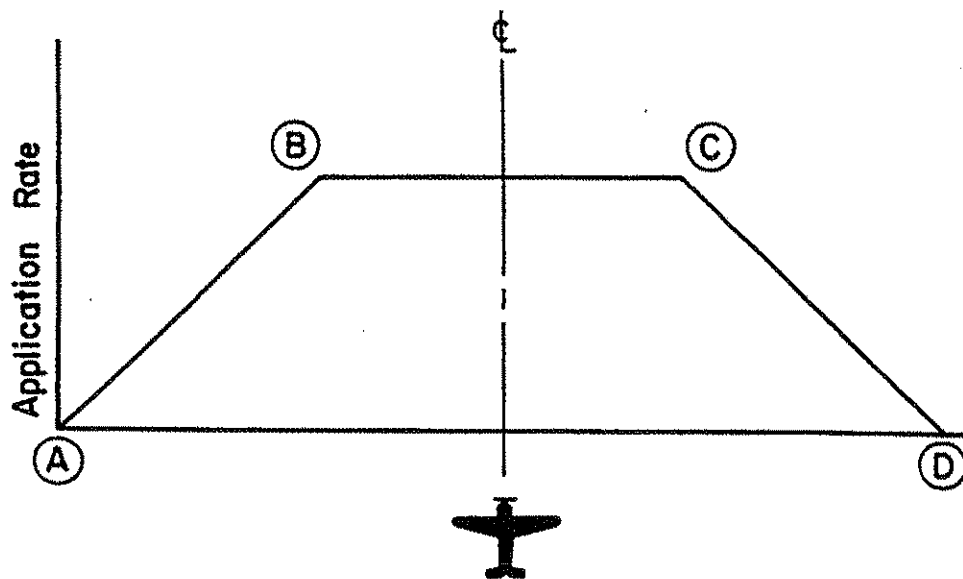

Figure 15. Trapezoidal Pattern from Granule-applying Device.

If distance AD (the distance between the two end pans containing zero granules) is 60 feet, and distance BC (the distance where granule catch per pan is relatively constant) is 30 feet, effective swath width is:

$$\text{effective swath width}_{\text{trapezoidal pattern}} = \frac{AD+BC}{2}$$

$$= \frac{60 \text{ ft.} + 30 \text{ ft.}}{2} = 45 \text{ ft.}$$

### Calibration with Existing Nozzles

The spray volume rate (*gpa*) actually delivered by an already-nozzled ag spray plane is its *actual boom output rate divided by the treatment progress rate*. The boom output rate is measured in *gallons per minute (gpm)*; the treatment progress rate is measured in *acres per minute (apm)*. In mathematical form, this is stated:

$$\text{spray volume rate (gpa)} = \frac{\text{boom output rate (gpm)}}{\text{treatment progress rate (apm)}}$$

$$\text{gallons sprayed per acre} = \frac{\text{gallons sprayed per minute}}{\text{acres sprayed per minute}}$$

Hence, in standard abbreviated form:

$$\text{gpa} = \frac{\text{gpm}}{\text{apm}}$$



## Determining Boom Output Rate (gpm) (with existing nozzles)

Use the nozzle manufacturer's nozzle performance data sheet and look up the nozzle flow rate value (*the per-nozzle gpm value*) that best corresponds to the at-nozzle pump pressure you intend to use. *Multiply the per-nozzle gpm value by the total number of working nozzles installed on the spray boom.* The mathematical product is the boom output rate (gpm.)

### Example:

The spray boom is fitted with fifty (50) #D4-46 nozzles. Pump pressure at the spray boom is 30 psi. The nozzle manufacturer's data sheet indicates a #D4-46 tip operated at 30 psi delivers 0.48 gpm.. What is the boom output rate?

*boom output rate = (flow rate per nozzle) X (number of working nozzles on boom)*

$$= (0.48 \text{ gpm}) \times (50 \text{ nozzles}) = 24 \text{ gallons per minute}$$

## Determining Treatment Progress Rate (apm) (with existing nozzles)

To determine the aircraft's treatment progress rate (apm), *multiply the width of spray plane's effective swath* (measured in feet) *by the spray plane's average airspeed* over the target site (measured in miles per hour) and *divide the resultant product by 495.*

### Example:

An aircraft has an effective swath of 55 feet and flies over a target site at 110 mph. What is its treatment progress rate (in acres per minute)?

$$\text{Treatment Progress Rate (apm)} = \frac{[\text{Swath Width (ft)}] \times [\text{Airpeed (mph)}]}{495}$$

$$\text{acres treated per minute} = \frac{[55 \text{ (ft)}] \times [110 \text{ (mph)}]}{495}$$

$$= 12.22 \text{ Acres per minute}$$

## Determining Spray Volume Rate (gpa)

Since both *gpm* and *apm* are now known, the actual spray volume rate (the total amount of spray being applied per treated acre) can now be determined by solving:

$$\text{Spray volume rate (gpa)} = \frac{\text{boom output rate (gpm)}}{\text{treatment progress rate (apm)}}$$

$$\text{gallons sprayed per acre} = \frac{\text{gallons sprayed per minute}}{\text{acres sprayed per minute}}$$

$$\text{gpa} = \frac{\text{gpm}}{\text{apm}}$$

Because values for both *gpm* and *apm* are known (obtained in the preceding steps above), the spray volume rate being applied at the target site can be calculated.

Thus, a spray plane flying at 110 *mph*, configured for a swath of 55 *ft.* from a boom fitted with 50 #D4-46 nozzles operated with an at-nozzle pump pressure of 30 *psi*, will be applying an actual spray volume rate of:

$$\begin{aligned} \text{gpa}_{\text{job}} &= \frac{24 \text{ gallons per minute}}{12.22 \text{ acres per minute}} \\ &= 1.96 \text{ gallons per acre} \end{aligned}$$

## Field Confirmation of System Performance

To confirm the amount of spray mix being delivered is, in fact, 2 gallons per acre -- perform the following six (6) steps:

- Step 1:** Use a flow meter and fill the spray hopper with a known quantity of water.
  
- Step 2:** Take the aircraft aloft and run the spray system for an accurately measured amount of time. A two minute timed run is usually adequate. (Note: If the delivery rate of the system is very low like in ULV spraying the measured time period should be longer to avoid error.) Record the airspeed maintained while actually spraying.

**Step 3:** Return the aircraft to the load site and accurately measure the amount of water needed to exactly restore the hopper to its initial level.

**Step 4:** Divide the gallonage needed to restore the hopper to its pre-test level by the time spent with the spray boom operating. This will yield actual gallons per minute (*gpm*).

$$gpm_{actual} = \frac{(gallons \text{ actually sprayed})}{(minutes \text{ of spray boom operation})}$$

**Note:**

The two methods of practical importance for changing spray system discharge rate (*i.e.*, boom output rate) *gpm* are:

- changing nozzle tips (preferable for most changes)
  
- adjusting pump pressure (useful only for very small changes.) \*\*

\*\* Adjusting pump pressure is useful only for making very small flow changes – because the *actual nozzle output (flow)* is proportional to the square root of pump pressure

(In practice, this means pump pressure must be quadrupled (increased 4X) in order to double (2X) a nozzle's flow rate.)

**Step 5:** The acres per minute (*apm*) actually treated during the test flight depends on the airspeed and effective swath of the aircraft. To confirm a test-flight *apm*, calculate as follows:

$$apm_{actual} = \frac{[effective\ swath(ft) \times speed(mph)]}{495}$$

$$gallons\ sprayed\ per\ acre = \frac{gallons\ sprayed\ per\ minute}{acres\ sprayed\ per\ minute}$$

(Rotary wing aircraft can vary *apm* more than fixed wing aircraft can because rotary wing craft offer more flexibility in airspeed.)

**Step 6:** Use the values obtained in Step 4 and Step 5 to confirm the actual gallons sprayed per acre during the test flight:

$$gallons\ per\ acre_{actual} = \frac{gallons\ per\ minute_{actual}}{acres\ per\ minute_{actual}}$$

# Review Questions for Chapter 7

(Answers: page 195)

01. An aerial applicator may not exceed the upper bound of any range of rates specified by a pesticide label.

True                  False

{text: Ch7; p 97}

Comment: \_\_\_\_\_  
\_\_\_\_\_

02. It is illegal for an aerial applicator to contract for and conduct an agricultural application of pesticide at a rate less than the lowest rate indicated on a pesticide label.

True                  False

{text: Ch7; p 97}

Comment: \_\_\_\_\_  
\_\_\_\_\_

03. A boom discharge rate is typically expressed in gallons per acre (gpa).

True                  False

{text: Ch7; p 97}

Comment: \_\_\_\_\_  
\_\_\_\_\_

04. A treatment progress rate is typically expressed in gallons per minute (gpm) because nozzle tip manufacturers usually state nozzle performance values in that manner.

True                  False

{text: Ch7; p 98}

Comment: \_\_\_\_\_  
\_\_\_\_\_

# Review Questions for Chapter 7

(Answers: page 195)

05. A treatment progress rate describes the amount of target site treated per unit of flight time.

True

False

{text: Ch7; p 98}

Comment: \_\_\_\_\_  
\_\_\_\_\_

06. A spray volume rate describes the amount of spray mixture (e.g., *gallons*) applied per unit of target site area (e.g., *Acres.*); hence, a spray volume rate is typically expressed in *gallons per acre* (gpa.)

True

False

{text: Ch7; p 108-110}

Comment: \_\_\_\_\_  
\_\_\_\_\_

07. From an equipment calibration viewpoint, the two independent factors that influence a spray volume rate are: the *boom discharge rate* and the *treatment progress rate*.

True

False

{text: Ch7; p 97-98}

Comment: \_\_\_\_\_  
\_\_\_\_\_

08. Strictly speaking, only two equipment variables (nozzle tip size, at-nozzle spray pressure) directly influence a boom discharge rate.

True

False

{text: Ch7; p 97}

Comment: \_\_\_\_\_  
\_\_\_\_\_

## Review Questions for Chapter 7

(Answers: page 196)

09. Once a spray volume rate has been decided upon, swath width becomes the only variable remaining that can directly influence the treatment progress rate.

**True**

**False**

{text: Ch7; p 99}

Comment: \_\_\_\_\_  
\_\_\_\_\_

10. The boom output rate need can be determined if the spray volume rate (gpa) has been decided upon and the variables influencing a treatment progress rate (apm) are known.

**True**

**False**

{text: Ch7; p 99}

Comment: \_\_\_\_\_  
\_\_\_\_\_

11. Usually, the best way to determine effective swath width is to conduct several computer-analyzed spray pattern test flights.

**True**

**False**

{text: Ch7; p 101}

Comment: \_\_\_\_\_  
\_\_\_\_\_

12. On fixed-wing aircraft, the preferred way to correct a wingtip-vortex-induced spray pattern problem is to shorten boom length.

**True**

**False**

{text: Ch7; p 104-105}

Comment: \_\_\_\_\_  
\_\_\_\_\_

## Review Questions for Chapter 7

(Answers: page 196)

13. To determine boom output rate, multiply the flow rate per nozzle by the number of nozzles present on the boom.

**True**

**False**

{text: Ch7; p 108}

Comment: \_\_\_\_\_  
\_\_\_\_\_

14. To determine an aircraft's actual spray volume rate, divide its actual boom output rate (gpm) by its actual treatment progress rate (apm.) .

**True**

**False**

{text: Ch7; p 110}

Comment: \_\_\_\_\_  
\_\_\_\_\_

15. In most cases, changing nozzle tip size is the best method to alter an aircraft's boom output rate.

**True**

**False**

{text: Ch7; p 111}

Comment: \_\_\_\_\_  
\_\_\_\_\_

16. Typically, in order to double a given nozzle's flow rate, pump pressure must be quadrupled.

**True**

**False**

{text: Ch7; p 111}

Comment: \_\_\_\_\_  
\_\_\_\_\_



# Chapter 8 - Pesticide Measurement Systems

## Introduction

In general, to properly use a concentrated pesticide product, a pesticide handler has to know (or determine) three things:

- target site size,
- amount of pesticide product needed, and
- amount of spray mix needed.

These in turn require familiarity with pesticide-related arithmetic and measurement system units.

## Types of Measure

Pesticide-related arithmetic usually involves measurements of:

- **Weight** -- measures how much of a substance is physically present. (Weight actually indicates how much the thing being measured is acted upon by gravity.) In pesticide-related arithmetic, weight typically indicates a measurement of a dry substance. In a few situations, the weight of a liquid (especially the weight of water) is used in calculations. *One gallon of water weighs 8.34 pounds.*
- **Liquid Measure** -- measures how much liquid is physically present by comparing it to the amount that will fill a standardized container (such as a teaspoon, pint or gallon). For pesticide applicators, the *fluid ounce* and the *U.S. gallon* are commonly-encountered liquid measurement units. *One U.S. gallon contains 128 fluid ounces.*
- **Distance** -- measures the amount of separation occurring between two things or places. Distance along a thing (or place) is called "length"; distance across a thing (or place) is termed "width." In pesticide-related arithmetic, distance is often stated in *feet*.
- **Area** -- measures the amount of surface present at a given site. In general, site area is calculated by multiplying the length of the site by the width of the site. The most common units of area used in pesticide-related arithmetic are *square foot* and *acre*. *An acre is a parcel of land that covers exactly 43,560 square feet.*

- **Volume** -- measures the amount of space occupied by a three-dimensional object. In general, volume is determined by multiplying together three different distances: length, width, and height. The most common unit of volume used in pesticide-related arithmetic is the *cubic foot*. *A cubic foot is the amount of space taken up by a box that is one foot wide, one foot long, and one foot high.*

## Units of Measure Commonly Used in Pesticide Work

Most pesticide labels indicate application rates and product concentrations in one of five U.S. measurement systems. Table 5 lists the more commonly-encountered units of each system.

**Table 5. Units of Measure Commonly Used in Pesticide Work**

Name of Measurement System	Name of Unit	Unit Symbol	Equivalence in another Unit of the same System	Metric Equivalent
U.S. Weight	ounce	oz.	437.5 grains = 1 oz.	28.35 grams
	pound	lb.	16 oz. = 1 lb.	0.45 kilograms
U.S. Liquid Measure	teaspoon	tsp.	0.167 fl. oz. = 1 tsp.	4.93 milliliters
	Tablespoon	Tbsp.	3 tsp. = 1 Tbsp.	14.79 milliliters
	fluid ounce	fl. oz.	2 Tbsp. = 1 fl. oz.	29.57 milliliters
	cup	cp.	8 fl. oz. = 1 cp.	236.56 milliliters
	pint	pt.	2 cp. = 1 pt.	0.473 liters
	quart	qt.	2 pt. = 1 qt.	0.946 liters
	gallon	gal.	4 qt. = 1 gal.	3.785 liters
U.S. Length	inch	in.	0.083 feet = 1 inch	2.54 centimeters
	foot	ft.	12 in. = 1 ft.	30.48 centimeters
	yard	yd.	3 ft. = 1 yd.	0.914 meters
	mile	mi.	5280 ft. = 1 mi.	1.6 kilometers

**Table 5. (continued)**

Name of Measurement System	Name of Unit	Unit Symbol	Equivalence in another Unit of the same System	Metric Equivalent
U.S. Area	square inch	sq. in.	0.007 sq. ft. = 1 sq. in.	6.45 sq. centimeters
	square foot	sq. ft.	144 sq. in. = 1 sq. ft.	0.093 sq. meters
	square yard	sq. yd.	9 sq. ft. = 1 sq. yd.	0.836 sq. meters
	acre	Ac.	43,560 sq. ft. = 1 Ac.	0.405 hectares
	square mile	sq. mi.	640 Ac. = 1 sq. mi.	2.59 sq. kilometers
U.S. Volume	cubic inch	cu. in.	0.00058 cu. ft. = 1 cu. in.	16.39 cu. centimeters
	cubic foot	cu. ft.	1728 cu. in. = 1 cu. ft.	0.028 cu. meters
	cubic yard	cu. yd.	27 cu. ft. = 1 cu. yd.	0.765 cu. meters
	Acre-foot	Ac-ft.	43,560 cu. ft. = 1 Ac-ft.	1219.68 cu. meters

## Measurement Unit Conversion

Whenever working with units of measure like those shown in Table 5, the applicator should note:

- Be on guard when you see the word "ounce" (on pesticide labeling or elsewhere). Be sure that you know which system is being referred to. As shown in Table 5, an ounce is a unit of weight (16 ounces = 1 pound). *However, "ounce" is sometimes written when "fluid ounce" is meant. These are NOT interchangeable terms. They measure different things. The best thing to do, is avoid using either one whenever possible. (Indicate any part of a pound or gallon as a decimal fraction.)*
- For each unit listed in Table 5, an equivalent amount is stated in another unit of the same system and in metric form. Factor-unit use of equivalence values enables any measurement to be re-stated (converted) in different units.

**Example:**

(To determine how many square yards are present in 1 acre:)

$$\begin{aligned}
 \text{Square Yards per Acre} &= \frac{1 \text{ Square Yard}}{9 \text{ Square Feet}} \times \frac{43,560 \text{ Square Feet}}{1 \text{ Acre}} \\
 &= \frac{43,560 \text{ Square Yards}}{9 \text{ Acres}} \\
 &= 4,840 \text{ square yards per acre}
 \end{aligned}$$

**NOTE:**

Four equivalence relationships NOT listed in Table 5 that pesticide applicators often find useful for changing from one system of measure to another include:

- a) One gallon of water weighs 8.34 pounds.  
(Converts US Liquid Measure to US Weight, or vice versa.)

$$\text{Example: } \frac{300 \text{ gal. water}}{\text{hopperful}} \times \frac{8.34 \text{ lbs.}}{1.0 \text{ gal. water}} = \frac{2,502 \text{ lbs.}}{\text{hopperful}}$$

- b) One gallon occupies 231 cubic inches.  
(Converts US Liquid Measure to US Volume or vice versa.)

$$\text{Example: } \frac{300 \text{ gal. water}}{\text{hopperful}} \times \frac{231 \text{ cubic inches}}{1.0 \text{ gal. water}} = \frac{69,300 \text{ cubic inches}}{\text{hopperful}}$$

- c) One cubic foot holds 7.48 gallons.  
(Converts US Volume to US Liquid Measure or vice versa.)

$$\text{Example: } \frac{300 \text{ gal. water}}{\text{hopperful}} \times \frac{1.0 \text{ cubic foot}}{7.48 \text{ gal. water}} = \frac{40.11 \text{ cubic feet}}{\text{hopperful}}$$

- d) One acre-inch holds 27,150 gallons.  
(Converts US Volume to US Liquid Measure or vice versa.)

$$\begin{aligned} \text{Example: } & \frac{1 \text{ hopperful}}{300 \text{ gal. water}} \times \frac{27,150 \text{ gal. water}}{1.0 \text{ Acre-inch}} \times \frac{0.25 \text{ Acre-inch}}{\text{entire site}} \\ & = 22.6251 \frac{\text{hopperfuls}}{\text{entire site}} \end{aligned}$$

## Review Questions for Chapter 8

(Answers: page 196)

01. On most modern pesticide labels, user instructions for dilution rates and spray volume rates stated are usually expressed only in metric units of measure.

**True**

**False**

{text: Ch8; p 118}

Comment: \_\_\_\_\_  
\_\_\_\_\_

02. One hundred gallons of water weighs 834 pounds.

**True**

**False**

{text: Ch8; p 117}

Comment: \_\_\_\_\_  
\_\_\_\_\_

03. One fluid ounce of water (U.S. Liquid Measure) weighs exactly one ounce of U.S. Weight.

**True**

**False**

{text: Ch8; p 120}

Comment: \_\_\_\_\_  
\_\_\_\_\_

04. The basic unit of U.S. Volume is the square inch.

**True**

**False**

{text: Ch8; p 119}

Comment: \_\_\_\_\_  
\_\_\_\_\_

## Review Questions for Chapter 8

(Answers: page 196)

05. The cubic inch is the basic unit of U.S. Area.

**True**            **False**

{text: Ch8; p 119}

Comment: \_\_\_\_\_  
\_\_\_\_\_

06. For all practical purposes, the terms *acre* and *acre-foot* are synonymous; they have identical values.

**True**            **False**

{text: Ch8; p 119}

Comment: \_\_\_\_\_  
\_\_\_\_\_

07. One (1) fluid ounce is equivalent to six (6) teaspoons; 5,280 feet is equivalent to one (1) mile.

**True**            **False**

{text: Ch8; p 118}

Comment: \_\_\_\_\_  
\_\_\_\_\_

08. Any measurement expressed in U.S. Measurement System units can be expressed in Metric System units.

**True**            **False**

{text: Ch8; p 118-119}

Comment: \_\_\_\_\_  
\_\_\_\_\_

## Notes

---



## Chapter 9 - Using a Dry Formulation to Prepare a Spray

### Introduction

Many pesticides are formulated as dry products designed to be mixed with water and applied as a spray. *The principal dry formulations designed for dilution before use are:*

- *Soluble Powders (SP),*
- *Wettable Powders (WP),*
- *Dry Flowables (DF), and*
- *Water-Dispensable Granules (WDG).*

Dry pesticide products are usually measured in US Weight (pounds). *The amount of active ingredient present in the formulated product is usually indicated as a percentage of total product weight.* Typically, this percentage is shown on the pesticide label as a number followed by an abbreviation indicating the formulation type.

### For Example:

**75 WP** -- indicates a Wettable Powder formulation consisting of 75% active ingredient (the other 25% is carrier, surfactant, etc.)

**90 SP** -- indicates a Soluble Powder formulation consisting of 90% active ingredient (the other 10% is carrier, surfactant, etc.)

In both cases, the total contents of a package is measured in US Weight (pounds). Thus, a package of each product might contain 25 pounds of pesticide formulation.

*Although both packages contain the same amount of formulated product (25 pounds) the amount of actual pesticide (the active ingredient) present in each package is quite different.* This fact is very important to the person who needs to make up a batch of spray mix. *It is also one of the reasons why the pesticide label should always be read carefully.*

The arithmetic used for preparing a batch of spray mix based on *pounds of pesticide product* is slightly different than the arithmetic needed for preparing spray mix based on *pounds of active ingredient*. Each of these situations is discussed below. In each case, the arithmetic is illustrated step-by-step.

## Situation 1: Label rate stated as Pounds of Formulated Product.

This is the most common situation for dry pesticide products designed to be mixed with water and applied as spray. However, *always read the pesticide label carefully* and make sure that the rate statement on the label actually says "pounds of product" or "pounds of formulation". *Some labels are not clearly worded*. If the "Pests Controlled" section of the label only gives the label rate as "pounds" or "pounds per acre", **be sure** to look elsewhere on the label and confirm that they mean "pounds of product" and not "pounds of active ingredient" **before** you prepare a batch of spray mix.

Typically, a label rate based on pounds of formulated product will be indicated either as:

- a) pounds of formulation needed *per unit of diluent* (gallons of spray mix water), or
- b) pounds of formulation needed *per unit of target site* (acres to be treated).

**Case A:** The dry formulation is to be mixed with water, and the pesticide label rate is given as **pounds of product per 100 gallons of water**. How do you go about preparing a batch of spray mix?

To prepare the spray mix, you must first know two things:

- **The total amount of water needed for the entire job.** To determine this, *read the label and decide how many gallons of spray you want to apply per acre*. Then, multiply the spray volume rate desired (gallons per acre) by the total number of acres to be treated.
- **The capacity of your sprayer tank** ( gallons per tank). *The best way to determine this is by direct measurement.*

Once these two things are known, you can use the label information and calculate:

- **The total pounds of pesticide product needed for the entire job.** To do this, multiply the total amount of spray mix needed (gallons per job) by the label rate.
- **The amount of pesticide product needed per tankful of spray mix.** To calculate this, multiply the capacity of the sprayer tank by the label rate.

**NOTE:** Use this same procedure to calculate the amount of product needed to make up a batch of spray mix that is less than a full tank (the only difference is the number of gallons of water in the tank is less). This is illustrated in the example below.

**Example for Case A:** (label rate given as pounds of product per amount of water)

You want to use a 75 WP to treat 30 acres of pecans. The spray hopper's capacity is 200 gallons. The pesticide label says to mix *2 pounds of product per 100 gallons of water* and apply as a spray using 5 to 15 gallons of water per acre. Your aircraft is calibrated to put out 5 gallons per acre, and you intend to use it "as is." Thus, you need to determine:

- **How many gallons of spray mix are needed for the entire job?**
- **How much 75 WP needs to be on hand for this job?**

**Solution:**

**Step 1:** First, note that because the label rate is based on pounds of **product**, the *percentage of active ingredient present in the formulation does not influence your calculations*. (If it were a 90 WP, the calculations would be the same as those for a 50 WP – assuming both label rates were based on **amount of formulated product**.)

**Step 2:** List all factors already known:

- a) the pesticide product (75 WP) is measured in pounds
- b) size of the target site = 30 acres
- c) capacity of the sprayer tank = 500 gallons
- d) label rate = 2 pounds of *product* per 100 gallons of water
- e) spray volume rate desired = 5 gallons of spray mix per acre

**Step 3:** Determine total gallons of spray mix needed for the job:

*(spray volume rate desired) x (acres treated) = total gallons of spray needed*

$$\frac{5 \text{ gallons}}{1 \text{ acre}} \times \frac{30 \text{ acres}}{1 \text{ job}} = \text{total gallons of spray needed}$$

$$\frac{(5 \times 30) \text{ gallons}}{1 \text{ job}} = 150 \text{ gallons of spray needed for the job}$$

**Step 4:** Calculate the total amount of 75 WP needed on hand:

*(total gallons of spray needed) x (label rate) = total pounds of product needed*

$$\frac{150 \text{ gallons of spray}}{1 \text{ entire job}} \times \frac{2 \text{ pounds of product}}{100 \text{ gallons of spray}} = \text{total pounds of product needed}$$

$$\frac{(150) \times (2) \text{ pounds of product}}{(1) \times (100) \text{ entire job}} = \text{pounds of product needed per job}$$

$$\frac{300 \text{ pounds of product}}{100 \text{ entire job}} = 3 \text{ pounds of product needed for entire job}$$

**Case B:** The dry formulation is to be mixed with water, and the label rate is given as **pounds of product per unit area of target site** (usually per acre, but sometimes per 1000 square feet). How do you go about preparing a batch of spray mix?

To prepare the spray mix, you must know:

- **The total amount of water needed for the job.** To determine this, *read the label and decide how many gallons of spray you want to apply per acre.* Then, *multiply the spray volume rate desired (gallons per acre) by the total number of acres to be treated.*

$$(\text{gallons needed per acre}) \times (\text{number of acres to treat}) = \text{total gallons needed}$$

- **The capacity of the sprayer tank (gallons per tank).** *The best way to determine this is by direct measurement.*

Once these two things are known, use the label information and calculate:

- **The total pounds of pesticide product needed for the entire job.** To do this, *multiply the total number of acres to be treated by the label rate:*

*(total number acres to be treated) x (label rate) = total pounds of product needed*

- the amount of pesticide product needed per hopperful of spray mix. To calculate this, *multiply the hopper's capacity by the label rate:*

*(hopper capacity) x (label rate) = pounds of product needed per hopperful*

**NOTE:** Use this same procedure to calculate the amount of product needed to make up less than full hopper of spray mix (the only difference is the total gallons of water in the hopper is less). This is illustrated in the example below.

**Example for Case B:** (label rate given as pounds of product per unit area of target site)

You want to treat 38 acres of grapefruit with a 90 SP. The spray hopper holds 250 gallons. The pesticide label says to apply 0.5 pounds of product per acre using 5 to 15 gallons of water per acre. Your aircraft is calibrated to put out 10 gallons per acre, and you intend to use it "as is." You have several questions:

**How many gallons of spray mix are needed for the entire job?**

**How much 90 SP is needed on hand?**

**How many hopperfuls of spray will have to be made up?**

**Will a partial load be needed; and if so, how many gallons of spray?**

**How many acres can be treated per tankful of spray mix?**

**How many pounds of 90 SP should be put in each full tank load?**

**How many pounds of 90 SP should be put in the partial tank load?**

**Solution:**

**Step 1:** First, note that because the label rate is based on pounds of **product**, the percentage of active ingredient present in the formulation *does not influence your calculations*.

**Step 2:** List the factors already known:

- a) the pesticide product (90 SP) is measured in pounds
- b) size of the target site = 38 acres
- c) hopper capacity = 250 gallons
- d) label rate = 0.5 pounds of *product* per acre
- e) spray volume rate desired = 10 gallons of spray mix per acre

**Step 3:** Determine the total gallons of spray mix needed:

$$(10 \text{ gallons per acre}) \times (38 \text{ acres per job}) = \text{total gallons of spray mix needed}$$

$$\frac{10 \text{ gallons}}{1 \text{ acre}} \times \frac{38 \text{ acres}}{1 \text{ job}} = \text{total gallons of spray mix needed}$$

$$\frac{(10 \times 38) \text{ gallons}}{1 \text{ job}} = 380 \text{ gallons of spray mix needed for the job}$$

**Step 4:** Calculate the amount of 90 SP needed on hand:

$$(\text{total acres treated}) \times (\text{label rate}) = \text{total pounds of product needed}$$

$$\frac{38 \text{ acres}}{1 \text{ job}} \times \frac{0.5 \text{ pounds of product}}{1 \text{ acre}} = \text{total pounds of product needed}$$

$$\frac{(38 \times 0.5) \text{ pounds of product}}{(1 \times 1) \text{ entire job}} = \text{total pounds of product needed for the job}$$

$$\frac{19 \text{ pounds of product}}{1 \text{ entire job}} = 19 \text{ pounds of product needed}$$

**Step 5:** Determine how many hopperfuls of spray mix are needed. *To do this, divide the total gallons of spray mix needed for the job by hopper capacity:*

$$\frac{\text{total gallons of spray mix needed for job}}{\text{hopper capacity (in gallons)}} = \text{total number of hopperfuls needed}$$

$$\frac{380 \text{ gallons spray mix needed for the job}}{250 \text{ gallons spray mix per hopperful}} = 1.52 \text{ hopperfuls needed for the job}$$

**NOTE:** Since the number of hopperfuls (1.52) is not a whole number, you will need one full load of spray and one partial load.



**Step 6:** Determine the number of acres treated per hopperful of spray mix. *To do this, divide the hopper capacity (in gallons) by the spray volume rate the aircraft will actual apply per acre:*

$$\frac{\text{hopper capacity}}{\text{actual spray volume rate}} = \text{acres treated per hopperful of spray mix}$$

$$\frac{250 \text{ gallons per hopperful}}{10 \text{ gallons spray mix per acre}} = 25 \text{ acres treated per hopperful of spray mix}$$

**Step 7:** Determine how many pounds of the 90 SP should be in the full hopper load. *Do this by multiplying the acres treated per hopperful of spray mix by the label rate:*

$$(\text{acres per hopperful}) \times (\text{label rate}) = \text{pounds of product needed per hopperful}$$

$$\frac{(25 \text{ acres})}{(1 \text{ hopperful})} \times \frac{(0.5 \text{ pounds of product})}{(1 \text{ acre})} = \text{pounds of product needed per hopperful}$$

$$\frac{(25 \times 0.5) \text{ pounds of product}}{(1 \times 1) \text{ hopperfuls of spray}} = 12.5 \text{ pounds of product per hopperful of spray}$$

**Step 8:** Calculate how many gallons of spray mix must be prepared for the partial hopper load. *To do this, multiply hopper capacity by the fractional amount of a hopper load (determined in Step 5) needed:*

$$(\text{hopper capacity}) \times (\text{fraction of load capacity needed}) = \text{gallons needed in partial load}$$

*(250 gallons per full hopper) x (0.52 hopperfuls needed) = gallons needed in partial load*

*(250 x 0.52) gallons = 130 gallons needed in partial load*

**Step 9:** Determine how many pounds of 90 SP should be put in the partial load. *To do this, use a "two-stage" calculation (this is because the label rate is in pounds per acre, but the spray volume rate is in gallons per acre):*

**Step 9a:** *First, find the acreage treated by the partial hopperful. To do this, divide the gallons of spray mix comprising the partial load by the spray volume rate:*

*$$\frac{\text{(gallons in partial load)}}{\text{(spray volume rate)}} = \text{acreage treated by partial load}$$*

*$$\frac{\text{(130 gallons per partial load)}}{\text{(10 gallons of spray mix per acre)}} = 13 \text{ acres treated by partial load}$$*

**Step 9b:** *Then, calculate the pounds of pesticide product needed for this amount of acreage. Do this by multiplying the number of acres treated per partial load by the label rate:*

*(acres per partial load) x (label rate) = lbs. of product needed in partial load*

*(13 acres per partial load) x (0.5 lbs. per acre) = 6.5 lbs. product per partial load*

## Situation 2:

### Label rate stated as Pounds of Active Ingredient

This situation does not occur often for dry pesticide products designed to be mixed with water. But it can. *Always read the pesticide label carefully* and make sure that the rate statement actually says "pounds of *active ingredient*." Some labels are not clearly written. If the "Pests Controlled" section of the label only gives the label rate as "pounds" or "pounds per acre", be sure to look elsewhere on the label and confirm that it means "pounds of *active ingredient*" and not "pounds of *pesticide product*" before you prepare a batch of spray mix using the methods described below.

Typically, a label rate based on pounds of active ingredient (AI) will be indicated as:

- pounds of active ingredient (AI) per unit of diluent (gallons of spray mix water),  
(Example: "...apply as a spray containing 1.0 pound of AI in 100 gallons of water...")
- pounds of active ingredient (AI) per unit of target site (acres to be treated)  
(Example: "...apply 1.0 pound of AI per acre in sufficient water to obtain thorough coverage...")

In either case, the FIRST thing to do is: **convert the label rate**. In other words, change the label rate from ***pounds of active ingredient*** TO ***pounds of pesticide product***. After the label rate is expressed as pounds of pesticide product, use the arithmetical procedures described in the examples given earlier for dry formulations.

To convert the label rate of a dry formulation that mentions pounds of active ingredient (AI) to a label rate expressed as pounds of pesticide product, use the following formula:

$$\frac{(\text{label rate in pounds of AI}) \times (100\%)}{(\text{percent AI present in the product})} = \text{label rate in pounds of pesticide product}$$

**Case A:** The dry formulation is to be mixed with water, and the pesticide label rate is given as **2 pounds of active ingredient per 100 gallons of water**. How do you go about determining how much *formulated pesticide product* should be put in the spray tank if you want to make some particular amount of spray mix?

**Step 1:** Read the product label to see what percentage of the formulated product is active ingredient.

**Note:** In many cases, this information is part of the trade name on the pesticide label. When reading the trade name, look for a number that accompanies the abbreviation for the formulation type

(for example: **Fairball 75 WP** indicates that the pesticide product "Fairball" is a **Wettable Powder** formulation whose composition is **75% active ingredient**.)

If the trade name does not contain such an abbreviation, the percentage of active ingredient present in the formulated product can always be found by reading the *active ingredient statement that is always present on the front panel of any pesticide label*.

For the following example, we assume the pesticide label indicates the formulation product contains **75% active ingredient (75% AI)**.

**Step 2:** Convert the label rate that mentions pounds of active ingredient to a *label rate that refers to pounds of pesticide product* by using the following formula:

$$\frac{\text{(label rate in pounds of AI)} \times (100\%)}{\text{(percent AI present in the product)}} = \text{label rate in pounds of pesticide product}$$

$$\frac{(2 \text{ pounds AI per 100 gallons of water}) \times (100\%)}{(75\% \text{ AI}) \text{ per lb. of formulated product}} = \text{label rate in pounds of pesticide product}$$

$$\frac{(2 \times 100) \text{ pounds per 100 gallons of water}}{(75) \text{ per lb. of formulated product}} = 2.67 \text{ lbs. of product per 100 gal. water}$$

NOTE: Any other pesticide arithmetic needed for a particular situation would follow the same step-by-step procedures discussed earlier for dry formulations.

**Case B:** The product is a dry formulation designed to be mixed with water, and the pesticide label rate is given as **3 pounds of active ingredient per acre** of target site. How do you go about determining how much *formulated pesticide product* should be put into the spray tank if you want to make some particular amount of spray mix?

**Step 1:** Read the product label to see what percentage of the formulated product is active ingredient.

NOTE: In many cases, this information is part of the trade name on the pesticide label. When reading the trade name, look for a number that accompanies the abbreviation for the formulation type (for example: **Goodjob 90 SP** indicates that the pesticide product "Goodjob" is a **Soluble Powder** formulation whose composition is **90% active ingredient**.)

If the trade name does not contain such an abbreviation, the percentage of active ingredient present in the formulated product can be found by reading the *active ingredient statement that is always present on the front panel of any pesticide label.*

In the following example, we assume that the pesticide label indicates the product contains **90% active ingredient (90% AI).**

**Step 2:** Convert the label rate that mentions pounds of active ingredient to a label rate that refers to pounds of pesticide product by using the following formula:

$$\frac{(\text{label rate in pounds of AI}) \times (100\%)}{(\text{percent AI present in the product})} = \text{label rate in pounds of pesticide product}$$

$$\frac{(3 \text{ pounds AI per acre}) \times (100\%)}{(90\% \text{ AI per lb. of formulated product})} = \text{label rate in pounds of pesticide product}$$

**NOTE:** All additional pesticide arithmetic needed for a particular situation entails using the same procedures discussed earlier for dry formulations.

### **Situation 3:**

#### **Label rate stated as Percent Active Ingredient in Spray Mix.**

This is the least common situation for dry products mixed with water. Sometimes the pesticide labeling might indicate a range of rates (for example, a 1.0% - 3.0% spray). The pesticide label lists how much product to use for the lowest and highest rates --- but doesn't say how much product should be used to mix up some "custom rate" like 1.25%.

Let's say, experience tells you that this rate should be enough to do the job against the pest, and at the same time, minimize any impact on beneficial organisms present at the target site. How do you calculate the amount of product needed for your "custom" rate?

To determine how much dry pesticide product to use in order to mix up a spray containing a particular percent of active ingredient (AI), you must know six (6) things:

- the total gallons of spray mix desired;
- the percent of active ingredient (AI) present in the formulated pesticide;
- the kind of diluent you plan to use (usually, this is water);
- how much one (1) gallon of the diluent weighs (i.e., the weight of a gallon of water);
- the percent of active ingredient (AI) desired in the spray mix (i.e., your "custom rate");

- a special pesticide arithmetic formula.

The special formula looks like this:

$$\frac{(\text{gal. of spray mix}) \times (\% \text{ AI desired}) \times (\text{lbs. per gal. of diluent})}{(\% \text{ AI present in the formulated product})} = \text{lbs. of formulation needed}$$

### Example:

Your aircraft is set up to deliver *15 gallons of spray per acre*. You want to use a *80 SP product* to treat a *5-acre site*. The pesticide label says that depending upon site conditions and other factors, sprays containing 1% - 3% active ingredient (AI) are effective. The label says to *use water as a diluent*. You want to apply a *spray that contains 1.25% active ingredient (AI)*. Your spray hopper can hold 300 gallons. How many gallons of spray mix do you need to make up? How many pounds of the 80SP pesticide product do you need for this job?

### Solution:

**Step 1:** Compare "the facts of the situation" to the first five items mentioned in the six-item checklist (shown above). Use these facts to calculate any item that you have to.

- Total gallons of spray mix needed. This is not known beforehand; so, you have to calculate it. To determine total gallons needed, multiply the gallons of spray desired per acre by the number of acres to be sprayed:

$$\begin{aligned} \text{Total gallons of spray mix needed} &= (\text{gallons per acre}) \times (\text{acres treated}) \\ &= (15 \text{ gal. per acre}) \times (5 \text{ acres}) \\ &= 75 \text{ gallons of spray mix} \end{aligned}$$

- percent AI desired in the spray mix = 1.25%
- kind of diluent to be used = **Water** (you get this from the pesticide label)
- ⇒ weight of a gallon of water = **8.34 lbs. per gallon** (this is a value you "just have to know"; it is discussed earlier; see *Chapter 8: Pesticide Measurement Systems*).
- percent AI present in the formulated product = **80%** (this is because you are using an 80 SP; the "80" indicates that the formulation contains 80% AI)

**Step 2:** Use the special formula (shown below) and the values listed in Step 1 to calculate the amount of formulation that will be needed to prepare the batch of spray mix.

$$\frac{(\text{gal. of spray mix}) \times (\% \text{ AI desired}) \times (\text{lbs. per gal. of diluent})}{(\% \text{ AI in the formulated product})} = \text{lbs. of formulation needed}$$

$$\frac{(75 \text{ gal.}) \times (1.25 \% \text{ AI}) \times (8.34 \text{ lbs. per gal.})}{(80\% \text{ AI in the formulated product})} = \text{lbs. of formulation needed}$$

$$\frac{(75) \times (1.25) \times (8.34) \text{ lbs.}}{(80)} = \text{lbs. of formulation needed}$$

$$\frac{781.875 \text{ lbs.}}{80} = 9.77 \text{ lbs. of formulation needed}$$

**NOTE:** This is slightly more than 9 ¾ pounds. Many scales will not accurately measure a decimal amount like 0.77 lbs., also, your scale may be graduated in ounces. *To convert the decimal fraction (0.77 lbs.) to ounces, multiply the decimal fraction by the number of ounces in 1 pound:*

$$(0.77 \text{ pounds}) \times \frac{16 \text{ ounces}}{1 \text{ pound}} = \text{number of ounces in the fractional amount}$$

$$(0.77) \times (16) \text{ ounces} = 12.32 \text{ ounces}$$

This number rounds to 12 ounces.

Thus, the amount 9.77 lbs. can be very closely approximated if you use a scale and measure out **9 pounds 12 ounces** of the 80 SP. Mixing this amount of product with 75 gallons of water would yield a spray mix containing 1.25 % AI.



## Review Questions for Chapter 9

(Answers: page 196)

01. An unopened 50-pound bag of 60DF should contain exactly 30 pounds of active ingredient.

True

False

{text: Ch9; p 125}

Comment: \_\_\_\_\_  
\_\_\_\_\_

02. Exactly ninety percent (90%) of the active ingredient present in a 90SP is water soluble.

True

False

{text: Ch9; p 125}

Comment: \_\_\_\_\_  
\_\_\_\_\_

03. In general, whenever the label rate of a dry formulation is stated as "pounds of product" the concentration of active ingredient in the product has no influence on spray mix preparation calculations.

True

False

{text: Ch9; p 128}

Comment: \_\_\_\_\_  
\_\_\_\_\_

04. Whenever the label rate of a dry formulation is stated in terms of "pounds of product," the user's first arithmetical step should be to **convert the label rate** from "pounds of product" to "pounds of active ingredient."

True

False

{text: Ch9; p 128}

Comment: \_\_\_\_\_  
\_\_\_\_\_

## Review Questions for Chapter 9

(Answers: page 196)

05. The label rate of a 50WP specifies 2 pounds of product per 100 gallons of prepared spray mix. Thus, to treat a 30-acre site, an aircraft configured to apply 5 gallons per acre will need to load 150 gallons of water containing 3 pounds of 50WP

**True**

**False**

{text: Ch9; p 128-129}

Comment: \_\_\_\_\_  
\_\_\_\_\_

06. The label rate of a 50WP specifies 0.2 pounds of product per treated acre. Thus, to treat a 30-acre site, an aircraft configured to apply 5 gallons per acre will need to load 150 gallons of water containing 3 pounds of 50WP.

**True**

**False**

{text: Ch9; p 129-134}

Comment: \_\_\_\_\_  
\_\_\_\_\_

07. To convert a label rate of a dry formulation that mentions pounds of active ingredient (AI) to a label rate expressed in pounds of pesticide product, divide the stated label rate by the percentage AI present in the formulation and multiply the quotient by 100%.

**True**

**False**

{text: Ch9; p 135}

Comment: \_\_\_\_\_  
\_\_\_\_\_

## Review Questions for Chapter 9

(Answers: page 197)

08. The label rate of a 50SP states, "Apply 0.25 pound of active ingredient per acre." This can be accomplished by applying 2 pounds of product per acre.

**True**

**False**

{text: Ch9; p 135}

Comment: \_\_\_\_\_  
\_\_\_\_\_

09. In order to prepare a water-based spray containing a desired percentage of active ingredient (e.g., 1.5% AI) from a 50WP product, you must know the weight of a gallon of water.

**True**

**False**

{text: Ch9; p 139}

Comment: \_\_\_\_\_  
\_\_\_\_\_

10. In order to prepare a water-based spray containing a desired percentage of active ingredient (e.g., 1.5% AI) from a 50WP product, you must calculate the relative weight of the active ingredient present in the formulation.

**True**

**False**

{text: Ch9; p 139}

Comment: \_\_\_\_\_  
\_\_\_\_\_

11. A 90SP is a water soluble powder that contains exactly 9.0 pounds of active ingredient per gallon of formulated pesticide product.

**True**

**False**

{text: Ch9; p 125}

Comment: \_\_\_\_\_  
\_\_\_\_\_

## Notes

---

# Chapter 10 - Using a Liquid Formulation to Prepare a Spray

## Introduction

Many pesticides are formulated as liquids designed to be mixed with water and applied as spray. The principal liquid formulations designed to be diluted before use are *Emulsifiable Concentrates (EC)*, *Solutions (S)*, *Flowables (F)*, and *Soluble Liquids (L or SL)*. In the United States, these pesticide products are usually measured in US Liquid Measure (gallons).

The amount of active ingredient present in a liquid formulation is indicated on the front panel of the pesticide label in one of two ways:

- the number of *pounds of active ingredient (AI) per gallon of formulation*, or
- the amount of active ingredient is listed as a *percentage of the formulation's total weight*.

Sometimes, a product label will use both methods to indicate the amount of active ingredient present in the formulation.

When "*pounds of AI per gallon*" is used, a "plain number" typically accompanies the abbreviation that indicates the formulation type (for example: 4L.) This abbreviation may form a part of the product's trade name.

When "*percent by weight*" is used, the percentage of active ingredient is usually indicated in the contents section on the label's front panel. It may also appear in the product trade name.

### For Example:

**Nu-Stuff 3.2 EC** -- indicates that the pesticide product "Nu-Stuff" is an Emulsifiable Concentrate that contains **3.2 pounds of active ingredient per gallon** of formulated product. No matter what one gallon of "Nu-Stuff" weighs; each gallon of "Nu-Stuff" contains exactly 3.2 pounds of AI. (The rest of the stuff in each gallon of product is solvent, surfactant, and other things that the manufacturer has put in to make the formulation work.)

**Wet-Stuff 90 SL** -- indicates that the pesticide product "Wet-Stuff" is a Soluble Liquid consisting of 90% active ingredient (AI). This means that 90% of the total *net weight* of any measured amount (*gallon, quart, pint*, etc.) of "Wet-Stuff"

contents in the package is the actual pesticide chemical (the other 10% of the *weight* is due to surfactant or other things that the manufacturer puts in to make the formulation work).

In most cases, the "*pounds AI per gallon of product*" method makes pesticide arithmetic very simple. This is true even if you desire to mix and load using a "custom rate" that falls in the mid-range of the label's recommended usage rates.

Typically, liquid products that indicate percent active ingredient give label rates based on the amount of *product* needed. When this is the case, the pesticide arithmetic is very simple.

However, if liquid products have label rates based on the amount of *active ingredient* (AI) needed, the arithmetic is a little more complex. In such cases, it is *very important* to note that two different types of measure (*US Weight* and *US Liquid Measure*) have to be considered and dealt with. To figure out the pounds of AI present per gallon of formulated product, you must know the *net weight of a gallon* of that product. (Net weight is usually indicated on the front panel of the pesticide label.)

The pesticide arithmetic used for preparing a batch of spray mix based on amount of liquid pesticide product is slightly different than the arithmetic needed for preparing spray mix based on amount of active ingredient present in a liquid product. Each situation is discussed below, and the pesticide arithmetic is illustrated step-by-step.

## **Situation 1:**

### **Label rate stated as amount of formulated product.**

This is the most common situation for liquid pesticide products mixed with water. However, *always read the pesticide label carefully* and make sure that the rate statement indicated on the label actually refers to "pints (or quarts, etc.) of product" or "pints of formulation." Some labels are not very clearly written. If the "Pests Controlled" section of the label only gives the label rate as "pints (qt., gal., etc.)" or "pints per acre," **be sure** to look elsewhere on the label and confirm that it means "*pints of product*" **before** you prepare a batch of spray mix.

Typically, a label rate based on amount of formulated product will be indicated either as:

- a) amount of formulation needed per unit of diluent (per gallon of spray mix water),

or,

- b) amount of formulation needed per unit of target site (per acre to be treated).

**Case A:** The product is a liquid formulation designed to be mixed with water, and the pesticide label rate is given as **pints of product per 100 gallons of water**. How do you go about preparing a batch of spray mix?

To prepare the spray mix, you must first know two things:

- **The total amount of water needed for the entire job.** To determine this, *read the label and decide how many gallons of spray you want to apply per acre*. Then, multiply the spray volume rate (gallons per acre) desired by the total number of acres to be treated:

*(gallons spray mix needed per acre) x (number of acres treated) = gallons of spray mix needed per job*

- **The capacity of the spray hopper** (total gallons per hopper). The best way to determine this is by direct measurement.

Once these two things are known, use the label rate and calculate:

- **The amount of pesticide product needed for the entire job.** To do this, *multiply the total amount of spray mix needed by the label rate* indicated on the pesticide label:

*(gallons of spray mix needed per job) x (label rate) = gallons of product needed per job*

- **The amount of pesticide product needed per hopperful of spray mix.** To calculate this, *multiply the capacity of the hopper by the label rate*:

*(hopper capacity) x (label rate) = amount of product needed per hopperful*

**NOTE:** Use this same formula to calculate the amount of product needed to make up less than a full load (the only difference is the total gallons of water in the hopper is less). This is illustrated in the example below.

**Example for Case A:** (label rate given as pints of product per amount of spray mix)

You want to use a 90 L to treat 160 acres. The hopper holds 300 gallons. The pesticide label says to mix *2 pints of product per 100 gallons of water* and apply as a spray using 5 to 15 gallons of water per acre. Your aircraft is calibrated to put out 5 gallons per acre, and you intend to use it "as is." You have several questions:

**How many gallons of spray mix are needed for the entire job?**

**How many gallons of 90 L are needed on hand for this job?**

**How many hopperfuls of spray mix do you have to make up?**

**Will you need to mix a partial load, and if so, how many gallons of spray?**

**How many pints of 90 L should be put in each full load?**

**How many pints of 90 L should be put in the partial load?**

**Solution:**

**Step 1:** First, note that because the label rate is based on pints of product, the *percentage of active ingredient present in the formulation does not influence your calculations*. (If it were a 50 L, the calculations would be the same as those for a 90 L -- assuming both label rates were based on **amount of formulated product**).

**Step 2:** List the factors that you already know:

- a) the pesticide product (90 L) will be measured in pints (or gallons)
- b) size of the target site = 160 acres
- c) hopper capacity = 300 gallons
- d) label rate = 2 pints of *product* per 100 gallons of water
- e) spray volume rate desired = 5 gallons of spray mix per acre

**Step 3:** Determine the total gallons of spray mix needed for the job:

*(spray volume rate per acre) x (total acres treated) = total gallons of spray mix needed*



*(5 gallons per acre) x (160 acres per job) = total gallons of spray mix needed*

$$\frac{(5 \times 160) \text{ gallons}}{1 \text{ job}} = 800 \text{ gallons of spray mix needed for the job}$$

Step 4: Calculate how much 90 L must be on hand for the job:

*(gallons of spray needed per job) x (label rate) = total pints of product needed*

$$\frac{800 \text{ gallons of spray}}{1 \text{ entire job}} \times \frac{2 \text{ pints of product}}{100 \text{ gallons of spray}} = \text{total pints of product needed}$$

$$\frac{1600 \text{ pounds of product}}{100 \text{ entire job}} = 16 \text{ pints of product needed for the job}$$

NOTE: To figure out how many gallons of 90 L product are needed, divide the number of pints needed by the number of pints present in one (1) gallon:

$$\frac{\text{total pints of product needed}}{\text{number of pints in 1 gallon}} = \text{total gallons of product needed on hand}$$

$$\frac{16 \text{ pints}}{8 \text{ pints per gallon}} = 2 \text{ gallons of product needed on hand}$$

**Step 5:** Determine how many hopperfuls of spray mix are needed. *To do this, divide the total gallons of spray mix needed for the entire job by the hopper's capacity:*

$$\frac{\text{gallons of spray mix needed for the job}}{\text{hopper capacity (in gallons)}} = \text{number of hopperfuls needed for the job}$$

$$\frac{800 \text{ gallons spray mix needed for the job}}{300 \text{ gallons spray mix per hopper}} = 2.67 \text{ hopperfuls needed for the job}$$

**NOTE:** Since the number of hopperfuls (2.67) is not a whole number, you will need to prepare two fullloads of spray and one partial load.

**Step 6:** Determine how many pints of 90 L are needed in each full load. *Do this by multiplying hopper capacity by the label rate:*

$$(\text{hopper capacity}) \times (\text{label rate}) = \text{pints of product needed per hopperful of spray}$$

$$\frac{(300 \text{ gallons})}{(1 \text{ hopperful})} \times \frac{(2 \text{ pints of product})}{(100 \text{ gallons of spray})} = \text{pints of product needed per hopperful}$$

$$\frac{(300 \times 2) \text{ pints of product}}{(1 \times 100) \text{ hopperfuls}} = 6 \text{ pints of product needed per hopperful}$$

**Step 7:** Calculate how many gallons of spray mix are needed in for the partial load. *To do this, multiply the hopper capacity by the fractional amount of a hopperful needed:*

$$\text{(hopper capacity)} \times \text{(fraction of hopperful needed)} = \text{gallons needed in partial load}$$

$$\text{(300 gallons per hopper)} \times \text{(0.67 hopperfuls needed)} = \text{gallons needed in partial load}$$

$$\text{(300} \times \text{0.67) gallons} = \text{200 gallons in partial load}$$

**Step 8:** Determine how many pints of 90 L are needed in the partial load. *Do this by multiplying the gallons of spray in the partial load by the label rate:*

$$\text{(gallons in partial load)} \times \text{(label rate)} = \text{pints of product needed in partial load}$$

$$\frac{\text{(200 gallons)}}{\text{(1 partial load)}} \times \frac{\text{(2 pints of product)}}{\text{(100 gallons of spray)}} = \text{pints of product needed in partial load}$$

$$\frac{\text{(200} \times \text{2) pints of product}}{\text{(1} \times \text{100) partial load}} = \text{4 pints of product in the partial load}$$

**Case B:** The pesticide product is a liquid intended for dilution with water. The pesticide label rate is given as **pints of product per unit area of target site** (usually per acre, but sometimes per 1000 square feet). How do you go about preparing a batch of spray mix?

To correctly prepare a batch of spray mix, you must know:

- **The total amount of water needed for the entire job.** To determine this, *read the label and decide how many gallons of spray you want to apply per acre.* Then, multiply the spray volume rate desired by the total number of acres to be treated:

$$\text{(gallons desired per acre)} \times \text{(number of acres to treat)} = \text{total gallons needed per job}$$

- **Hopper capacity (gallons).** The best way to determine this is by direct measurement. If necessary, refer to your sprayer's equipment manual for details.

Once these two things are known, use the label information and calculate:

- **The total pints of pesticide product needed for the entire job.** To do this, *multiply the total treatment site acreage by the label rate:*

$$\text{(total acres to treat)} \times \text{(label rate)} = \text{total pints of product needed for the job}$$

- **The amount of pesticide product needed per hopperful of spray mix.** To calculate this, *multiply hopper capacity by the label rate:*

$$\text{(hopper capacity)} \times \text{(label rate)} = \text{pints of product needed per hopperful}$$

**(Example for Case B: (label rate given as pints of product per acre of target site)**

You want to use a 90 L product to treat 120 acres. The aircraft's hopper capacity 300 gallons. The pesticide label says to apply 3 pints of product per acre using 5 to 20 gallons of water per acre. Your aircraft is calibrated to put out 7 gallons per acre, and you intend to use it "as is." You have several questions:

**How many gallons of spray mix are needed for the entire job?**

**How much 90 L needs to be on hand?**

**How many hopperfuls of spray mix need to make up?**

**Is a partial load needed, and if so, how many gallons of spray mix?**

**How many acres can be treated per hopperful of spray mix?**

**How many pints of 90 L should be in each full load of spray mix?**

**How many pints of 90 L should be in the partial load of spray mix?**

**Solution:**

**Step 1:** First, note that because the label rate is based on pints of **product**, the percentage of active ingredient present in the formulation *does not influence your calculations*. (If it were a 4 EC, the calculations would be the same as those for a 90 L -- assuming both label rates indicate the same amount of formulated product per acre).

**Step 2:** List the factors that you already know:

- a) the pesticide product (90 L) will be measured in pints
- b) target site size = 120 acres
- c) hopper capacity = 300 gallons
- d) label rate = 3 pints of **product** per treated acre
- e) spray volume rate desired = 7 gallons of spray mix per acre

**Step 3:** Determine the total gallons of spray mix needed for the entire 120-acre job:

$$\text{(spray volume rate)} \times \text{(total acres treated)} = \text{total gallons of spray mix needed}$$

$$(7 \text{ gallons per acre}) \times (120 \text{ acres per job}) = \text{total gallons of spray mix needed}$$

$$\frac{7 \text{ gallons}}{1 \text{ acre}} \times \frac{120 \text{ acres}}{1 \text{ job}} = \text{total gallons of spray mix needed}$$

$$\frac{(7 \times 120) \text{ gallons}}{1 \text{ job}} = 840 \text{ gallons of spray mix needed}$$

**Step 4:** Calculate how much 90 L must be on hand for the job:

$$\text{(acres treated per job)} \times \text{(label rate)} = \text{total pints of product needed}$$

$$\frac{120 \text{ acres}}{1 \text{ entire job}} \times \frac{3 \text{ pints of product}}{1 \text{ acre}} = \text{total pints of product needed}$$

$$\frac{(120 \times 3) \text{ pints of product}}{(1 \times 1) \text{ entire job}} = \text{total pints of product needed}$$

$$\frac{360 \text{ pints of product}}{1 \text{ entire job}} = 360 \text{ pints of product needed}$$

**Step 4a:** [Optional]. Convert pints needed to gallons needed. *To do this, divide the total pints needed by the number of pints present in one gallon.*

$$\frac{360 \text{ pints of product needed for job}}{8 \text{ pints per gallon}} = 45 \text{ gallons of product needed for the job}$$

**Step 5:** Determine how many hopperfuls of spray mix are needed. *To do this, divide the total gallons of spray mix needed by hopper capacity:*

$$\frac{\text{total gallons of spray mix needed}}{\text{hopper capacity}} = \text{number of hopperfuls needed for the job}$$

$$\frac{840 \text{ gallons of spray mix needed}}{300 \text{ gallons spray mix per tankful}} = 2.8 \text{ tankfuls needed for the job}$$

**NOTE:** Since the number of hopperfuls (2.8) is not a whole number, you will need **two full loads and one partial load.**

**Step 6:** Determine the number of acres treated per full hopper of spray mix. *To do this, divide hopper capacity by the spray volume rate:*

$$\frac{\text{hopper capacity}}{\text{spray volume rate}} = \text{acres per hopperful of spray mix}$$

$$\frac{300 \text{ gallons per hopperful}}{7 \text{ gallons per acre}} = 42.86 \text{ acres per hopperful of spray mix}$$

**Step 7:** Determine how many pints of 90 L are needed in each full load. *To do this, multiply the acres treated per hopperful of spray mix by the label rate*

*(acres per hopperful of spray) x (label rate) = pints of product needed per hopperful*

$$\frac{(42.86 \text{ acres})}{(1 \text{ hopperful})} \times \frac{(3 \text{ pts. of product})}{(1 \text{ acre})} = \text{pints of product needed per hopperful}$$

$$\frac{(42.86 \times 3) \text{ pints of product}}{(1 \times 1) \text{ hopperful}} = 128.58 \text{ pints of product needed per hopperful}$$

**Step 7a:** [Optional]. If desired, convert the pints of pesticide product needed to gallons of pesticide product needed. *To do this, divide the pints of product needed per hopperful of spray by the number of pints present in one gallon:*

*$\frac{\text{pints of product needed per hopperful}}{\text{number of pints in one gallon}} = \text{gallons of product needed per hopperful}$*

$$\frac{128.58 \text{ pints of product per hopperful}}{8 \text{ pints per gallon}} = 16.07 \text{ gallons of product needed per hopperful}$$

**Step 8:** Calculate how many gallons of spray mix are needed for the partial load. *To do this, multiply hopper capacity by the fractional amount of a hopperful needed:*

*(hopper capacity) x (fraction of hopperful needed) = gallons needed in partial load*

$$(300 \text{ gallons per hopperful}) \times (0.8 \text{ hopperfuls needed}) = \text{gallons needed in partial load}$$

$$(300 \times 0.8) \text{ gallons} = 240 \text{ gallons needed in partial load}$$



**Step 9:** Determine how many pints of 90 L should be put in the partial tank load. *To do this use a "three-stage" calculation (this is because the label rate is in pints per acre, but spray volume is in gallons per acre):*

**Step 9a:** First, determine the acreage treated by the partial load. To do this, divide the gallons of spray mix needed in the partial load by the spray volume rate:

$$\frac{\text{(gallons in partial load)}}{\text{(spray volume rate)}} = \text{acres treated per partial load}$$

$$\frac{\text{(240 gallons per partial load)}}{\text{(7 gallons per acre)}} = 34.29 \text{ acres per partial load}$$

**Step 9b:** Then, calculate the pints of pesticide product needed for this amount of acreage. Do this by *multiplying the number of acres treated per partial load by the label rate:*

$$\text{(acres per partial load)} \times \text{(label rate)} = \text{pints of product needed in partial load}$$

$$\text{(34.29 acres per partial load)} \times \text{(3 pints per acre)} = 102.87 \text{ pints of product per partial load}$$

**Step 9c:** [Optional]. If desired, convert the pints of product needed per partial load of spray mix to gallons of product needed. To do this, divide the pints of product needed by the number of pints present in one gallon:

$$\frac{\text{pints of product needed per partial load}}{\text{number of pints in one gallon}} = \text{gallons of product needed in partial load}$$

$$\frac{102.87 \text{ pints of product in partial load}}{8 \text{ pints per gallon}} = 12.86 \text{ gallons of product per partial tankful}$$

## Situation 2:

### Label rate stated as pounds of Active Ingredient

This situation *sometimes* occurs for liquid pesticide products designed to be diluted before use.

*Always read the pesticide label carefully* and make sure that the rate statement actually says "pounds of *active ingredient*." Some labels are not clearly written. If the "Pests Controlled" section of the label only gives the label rate as "pounds" or "pounds per acre," **be sure** to look elsewhere on the label and confirm that it means "pounds of *active ingredient*" and not "pounds of *pesticide product*" **before** you prepare a batch of spray mix using the methods described below.

Typically, a label rate based on pounds of active ingredient (AI) will be indicated as either:

- a) pounds of active ingredient (AI) needed per unit of diluent (usually, gallons of water), or
- b) pounds of active ingredient (AI) needed per unit of target site (acres to be treated).

**In either case**, the **FIRST** thing to do is: **convert the label rate**. Change the label rate from ***pounds of active ingredient*** to ***gallons of pesticide product***. After the label rate is expressed in gallons of pesticide product, the rest of the pesticide arithmetic follows the same step-by-step procedures discussed in the examples given earlier for liquid formulations.

**To convert the label rate of a liquid formulation that mentions pounds of active ingredient to a label rate that refers to gallons of pesticide product**, use the following formula:

$$\frac{\text{(label rate in pounds of AI)}}{\text{(pounds of AI per gallon of product)}} = \text{label rate in gallons of pesticide product}$$

## Examples: Converting Label Rates for Liquid Formulations

**Case A:** The liquid formulation is to be diluted with water, and the pesticide label rate is given as **3 pounds of active ingredient per 100 gallons of water**. How much *formulated pesticide product* should be put into the spray tank to make some particular amount of spray mix?

**Step 1:** Read the product label to see how many pounds of active ingredient are present in one gallon of the formulated product.

**NOTE:** In many cases, this information is part of the trade name indicated on the pesticide label. When reading the trade name, look for a number that accompanies the abbreviation for the formulation type (for example: **Fairball 2.67 EC** indicates that the pesticide product "Fairball" is an **Emulsifiable Concentrate** that contains **2.67 pounds of active ingredient (AI) per gallon of product**.

If the product name does not contain such an abbreviation, the amount of active ingredient present in the formulated product can be determined by reading the *active ingredient statement that is always present on the front panel of the pesticide label*.

For illustrative purposes, assume:

- ① the pesticide label indicates the product contains 2.67 pounds of active ingredient per gallon of formulation (the trade name indicates 2.67 EC), and
- ② the label rate says to mix 3 pounds of active ingredient (AI) per 100 gallons of spray mix..

**Step 2:** Convert the label rate stated as pounds of active ingredient to *a label rate that indicates gallons of pesticide product*. To do this, divide the AI-based label rate by the number of pounds of active ingredient present in one gallon of product:

$$\frac{\text{(AI-based label rate)}}{\text{(pounds of AI present per gallon of product)}} = \text{label rate in gallons of pesticide product}$$

$$\frac{\text{(3 pounds AI per 100 gallons of spray mix)}}{\text{(2.67 pounds of AI per gallon of product)}} = \text{label rate in gallons of pesticide product}$$

$$\frac{\text{(3 pounds AI) per 100 gallons of water}}{\text{(2.67 pounds AI) per gallon of product}} = 1.12 \text{ gal. of product per 100 gal. water}$$

**NOTE:** Once you know how much formulation to use per 100 gallons of spray mix, the pesticide arithmetic follows the same procedures as those discussed earlier for liquid formulations having rates based upon 100 gallons of spray mix.

**Case B:** The product is a liquid designed to be diluted with water, and the label rate is given as **1.5 pounds of active ingredient per acre** of target site. How much *formulated pesticide product* should be put into the spray tank if you want to make some particular amount of spray mix?

**Step 1:** **Read the product label** and determine how much active ingredient (pounds of AI) is present in one gallon of the formulated product.

**NOTE:** In many cases, this information is part of the trade name indicated on the pesticide label. When reading the trade name, look for a number that accompanies the abbreviation for the formulation type (for example: **Goodjob 4 EC** indicates that the pesticide product "Goodjob" is an **Emulsifiable Concentrate** formulation that contains **4 pounds of active ingredient per gallon** of formulation.

If the product name does not contain such an abbreviation, the amount of active ingredient present per gallon of formulated product can be found by reading the *active ingredient statement always present on the front panel of any pesticide label*.

For illustrative purposes, assume:

- ① the pesticide label indicates the product contains **4 pounds of active ingredient (AI) per gallon** (the label says **4 EC**).
- ② the label rate is given as "...**1.5 pounds of active ingredient (AI) per acre**."

**Step 2:** Convert the label rate stated in pounds of active ingredient to a label rate that indicates gallons of pesticide product. To do this, divide the AI-based label rate by the number of pounds of active ingredient present in one gallon of product:

$$\frac{\text{(AI- based label rate)}}{\text{(pounds of AI present per gallon of product)}} = \text{label rate in gallons of product}$$

$$\frac{\text{(1.5 pounds of AI per acre)}}{\text{(4 pounds AI per gallon of product)}} = \text{label rate in gallons of product per acre}$$

$$\frac{\text{(1.5) pounds AI per acre}}{\text{(4) pounds AI per gallon of product}} = 0.375 \text{ gallons of product per acre}$$

**Step 2a:** [Optional]. If desired, convert the decimal fraction of a gallon to standard units of US liquid measure. To do this, multiply the fractional gallons by the number of units (quarts, pints, etc.) contained in one gallon.  
Thus:

$$\text{(0.375 gallons of product per acre)} \times \text{(8 pints per gallon)} = 3 \text{ pints of product per acre}$$

**NOTE:** Once you know how much formulation is needed per acre, use the arithmetical procedures described earlier for liquid formulations having rates based upon amount of product per acre to solve specific instances.

### Situation 3:

#### Label rate stated as percent active ingredient (%AI) in spray mix.

This is the least common situation for preparing a batch of spray mix.

Generally, if the label rate is stated as percent active ingredient present in the spray mix, the label will also say how much formulated product (in fluid ounces, pints, quarts, etc.) should be added per unit liquid volume (tankful, gallon, 100-gallons, etc.) of spray mix. In such cases, no special arithmetic needs to be done; just follow the steps described earlier (see amount of product per 100 gallons of spray mix) in order to do the appropriate pesticide arithmetic.

However, sometimes the pesticide labeling might indicate a range of rates (for example, 1.0% - 3.0% spray). The pesticide label lists how much product to use for the lowest and highest rates but doesn't say how much product should be used to mix up an intermediate "custom rate" like 1.5%.

Sometimes, personal experience tells you that this "custom" rate is enough to do the job against the pest, and at the same time, will minimize any impact on the beneficial organisms present at the target site.

**Question:** How do you calculate the amount of product needed for a "custom" rate that specifies a certain %AI?

**Answer:** To determine how much liquid pesticide product to use in order to mix up a spray containing a custom percent of active ingredient (AI), you must know six (6) things:

- ① the total gallons of spray mix desired;
- ② the pounds of active ingredient (AI) present in one gallon of the pesticide product;
- ③ the kind of diluent that you plan to use (usually, this is water);
- ④ how much one (1) gallon of the diluent weighs (i.e., the weight of a gallon of water);
- ⑤ the percent of active ingredient (AI) desired in the spray mix (i.e., your "custom rate");
- ⑥ a special pesticide arithmetic formula.

**Example:**

Your aircraft is set up to deliver *10 gallons of spray per acre*. You want to use a *4 EC product* to treat a *30-acre site*. The pesticide label says a spray containing *1% - 3% active ingredient (AI)* is effective. The label also says *use water as a diluent*. You want to apply a *spray containing 1.5% active ingredient (AI)*. Your spray hopper holds 300 gallons. How many gallons of spray mix do you need? How many gallons of the 4 EC pesticide product do you need for this job?

**Solution:**

**Step 1:** Compare "the facts of the situation" to the first five items mentioned in the six-item checklist (shown on preceding page). Use these facts to calculate any item that you have to.

- Total gallons of spray mix needed. *To determine total gallons needed, multiply the gallons needed per acre by the number of acres to be sprayed:*

*Total gallons of spray mix needed = (gallons per acres) x (acres treated)*

$$= (10 \text{ gal. per acre}) \times (30 \text{ acres})$$

$$= (10 \times 30) \text{ gallons}$$

$$= 300 \text{ gallons of spray mix needed}$$

- pounds of AI present in one gallon of the formulated product = **4 pounds** (this is because you are using a 4 EC; the "4" indicates that the formulation contains 4 pounds of active ingredient (AI) per gallon.



- kind of diluent to be used = **Water** (you get this from the pesticide label)
- weight of a gallon of water = **8.34 lbs. per gallon** (this is a value you "*just have to know*"; it is discussed in *Chapter 8: Pesticide Measurement Systems*).
- percent AI desired in the spray mix = **1.5%**

**Step 2:** Use the "special formula" (shown below) and the values listed in Step 1 to calculate the amount of formulation that will be needed to prepare the batch of spray mix.

$$\frac{(\text{gal. of spray mix}) \times (\% \text{ AI desired}) \times (\text{lbs. per gal. of diluent})}{(\text{lbs of AI per gal. of pesticide product}) \times (100\%)} = \text{gallons of product needed}$$

$$\frac{(300 \text{ gal. of spray mix}) \times (1.5\% \text{ AI}) \times (8.34 \text{ lbs. per gal. of water})}{(4 \text{ lbs of AI per gal. of pesticide product}) \times (100\%)} = \text{gallons of product needed}$$

$$\frac{(300) \times (1.5) \times (8.34) \text{ gallons}}{(4) \times (100)} = \text{gallons of product needed}$$

$$\frac{3,753 \text{ gallons}}{400} = 9.38 \text{ gallons of product needed}$$

**NOTE:** In standard units of US Liquid Measure, the decimal value 9.38 gallons would be stated as "9 gallons plus 3 pints." **To convert any decimal fraction of a gallon to standard U.S. Liquid Measure, multiply the decimal fraction's value by the number of units (quarts, pints, fluid ounces, etc.) present in one gallon.**

**For example:** To convert the decimal value 9.38 gallons to other units of US Liquid Measure (say, gallons plus pints), set up your arithmetic as follows:

**Step 1:** Temporarily separate the "whole number" from the fractional part:

$$9.38 \text{ gallons} = (9 \text{ gallons}) + (0.38 \text{ gallons})$$

**Step 2:** Convert the fractional gallon to the desired unit of US Liquid Measure:

$$(0.38 \text{ gallons}) \times (8 \text{ pints per gallon}) = 3.04 \text{ pints}$$

**Step 3:** Recombine the "whole number" with the converted fractional part:

$$(3 \text{ gallons}) + (3 \text{ pints}) = \text{"3 gallons plus 3 pints"}$$

The same general procedure can be used to convert decimal fractions of a gallon to fluid ounces, cups, or quarts. The conversion values for these are listed in Table 5 (Chapter 8).

The main reason for making such conversions is to be able to use the measuring equipment that happens to be available at your particular facility. In pesticide work, being able to accurately measure the amount of product (concentrate) needed is a good way to avoid misapplication problems later.

## Review Questions for Chapter 10

(Answers: page 197)

01. An unopened 2.5-gallon jug of 4EC should contain exactly 10 pounds of active ingredient.

**True**

**False**

{text: Ch10; p 145}

Comment: \_\_\_\_\_  
\_\_\_\_\_

02. Exactly 90 percent (90%) of one (1) gallon of a 90SL is active ingredient.

**True**

**False**

{text: Ch10; p 145}

Comment: \_\_\_\_\_  
\_\_\_\_\_

03. In general, whenever the label rate of a liquid formulation is stated as "pints of product" the concentration of active ingredient in the product has no influence on spray mix preparation calculations.

**True**

**False**

{text: Ch10; p 148}

Comment: \_\_\_\_\_  
\_\_\_\_\_

04. Whenever the label rate of a liquid formulation is stated in terms of "pints of product," the user's first arithmetical step should be to convert the label rate from "pints of product" to "pints of active ingredient."

**True**

**False**

{text: Ch10; p 146-147}

Comment: \_\_\_\_\_  
\_\_\_\_\_

## Review Questions for Chapter 10

(Answers: page 197)

05. The label rate of a 5EC specifies 2 pints of product per 100 gallons of prepared spray mix. Thus, to treat a 40-acre site, an aircraft configured to apply 5 gallons per acre will need to load 200 gallons of water containing 0.5 gallons of 5EC

**True**

**False**

{text: Ch10; p 148}

Comment: \_\_\_\_\_  
\_\_\_\_\_

06. The label rate of a 90L specifies 0.25 pints of product per treated acre. Thus, to treat a 40-acre site, an aircraft configured to apply 4 gallons per acre will need to load 160 gallons of water containing 1.25 gallons of 90L.

**True**

**False**

{text: Ch10; p 148}

Comment: \_\_\_\_\_  
\_\_\_\_\_

07. To convert a label rate of a liquid formulation that mentions pounds of active ingredient (AI) to a label rate expressed in gallons of pesticide product, divide the stated label rate by the pounds of AI present in one gallon of the pesticide product..

**True**

**False**

{text: Ch10; p 158}

Comment: \_\_\_\_\_  
\_\_\_\_\_

## Review Questions for Chapter 10

(Answers: page 197)

08. The label rate of a 4EC states, "Apply 0.25 pounds active ingredient per acre." This can be accomplished by applying 1 cup of product per acre.

**True**      **False**

{text: Ch10; p 158}

Comment: \_\_\_\_\_  
\_\_\_\_\_

09. In order to prepare a water-based spray containing a desired percentage of active ingredient (e.g., 1.5% AI) from a 8F product, you must know the weight of a gallon of water.

**True**      **False**

{text: Ch10; p 163-165}

Comment: \_\_\_\_\_  
\_\_\_\_\_

10. In order to prepare a water-based spray containing a desired percentage of active ingredient (e.g., 1.5% AI) from a 5EC product, you must know the volume of active ingredient present per unit weight of formulation.

**True**      **False**

{text: Ch10; p 163}

Comment: \_\_\_\_\_  
\_\_\_\_\_

11. A 90SL is a water soluble liquid that contains exactly 9.0 pounds of active ingredient per gallon of formulated pesticide product.

**True**      **False**

{text: Ch10; p 145}

Comment: \_\_\_\_\_  
\_\_\_\_\_

## Notes

---

# Chapter 11 - Operations

Airspeed, nozzle tip size, boom configuration, spray pressure (or gate setting), dispersal height and effective swath width are set during calibration. Operation and pilotage remain. This chapter reviews the principles of operating procedure for aerial pesticide application.

## Pilot

Incontestably, pilot skill is the key to successful aerial application. His or her competence and capacity for timely and accurate judgment largely determines successful outcome. Thus, an aerial applicator pilot must be:

- aware of his or her *personal limitations* in aircraft operation. Pilot fatigue should never be allowed to become a contributing cause of an accident, injury or crash. To better manage fatigue:
  - regularly get sufficient sleep;
  - maintain a well-balanced diet;
  - take brief, scheduled, breaks during every workday;
  - establish and follow realistic task deadlines and work patterns.
- aware of the *aircraft's features and limitations*, including:
  - its airworthiness for the maneuvers needed;
  - its maximum load limit from short, rough, temporary airstrips;
  - its ability to emit the proper amount of pesticide product per unit of target site area; and
  - its capacity to deliver spray droplets having minimal spray drift potentials.
- knowledgeable of *weather factors* and their influence on aerial application work.
- able to correctly interpret and fully follow each *pesticide label's directions*.
- familiar with each pesticide product applied; including:
  - *first aid* responses required in the event of accidental over-exposure,
  - all *special precautions* required for its application, its
  - legitimate (*label-indicated*) *target sites*.

- capable of *crop recognition*; not only to insure the correct site is treated, but also, to delineate boundaries of adjacent non-target areas.
- able to determine the *best direction* to spray a site and being *adept at maneuvering* an aircraft loaded to maximum legal weight.
- capable of immediate and direct communication exchanges with on-site ground crew members (and other team personnel, as needed.)
- prepared to *refuse a customer's request* for spray service at a particular time (if the pilot thinks target site conditions at that time are a safety hazard or pose substantially elevated misapplication risks – e.g., people on-site or nearby, drift-promoting weather conditions, etc.)

The pilot on site (*i.e.*, *the pesticide applicator*) bears the burden of foremost responsibility for the decision to actually perform the pesticide treatment.

### Precautionary Actions

- Use a high-quality, properly-fitting, crash helmet and serviceable shoulder harness.
- Wear clean clothing. Maintain good personal hygiene. Many pesticides readily penetrate human skin – personal cleanliness significantly reduces the likelihood of illness resulting from exposure to pesticide.
- Without exception, fly *around* (rather than across) sensitive areas. In the “long term” this simple rule costs little – and pays huge dividends.
- Upon arrival at a target site, fly an *initial inspection pass* and *verify* that:
  - a) local *weather conditions* (wind velocity, air stability, etc.) are suitable for aerial application work;
  - b) *no people* (e.g., agricultural workers, trespassers, spectators, others) *or their vehicles* are within (or immediately adjacent) the target site;
  - c) all members of the ground crew are present, on station, and ready to implement their assigned duties.
  - d) all pilot-to-ground-crew communication links are functioning correctly.



## Application Methods

One “normal” flight pattern for aerial application is to sequentially fly bidirectional swaths over the target in straight, parallel lines. In areas too rugged for uniform altitude and speed, flight lines should follow the contours of the slopes. In hilly terrain, or where target sites are too hemmed in to permit contour flying, make all treatment passes *down slope*. Up-slope treatment is especially dangerous – under most circumstances, it is best avoided altogether.

Whenever possible, make swaths crosswind (to assist in overlap and coverage uniformity), and lengthwise (to reduce turnarounds.) Begin treatment on the downwind side of the target site – this avoids flying through any spray droplets suspended in the air from previous swaths. To promote uniform field coverage, utilize swath marking (via an automatic flagging device, DGPS, etc.) on each treatment pass.

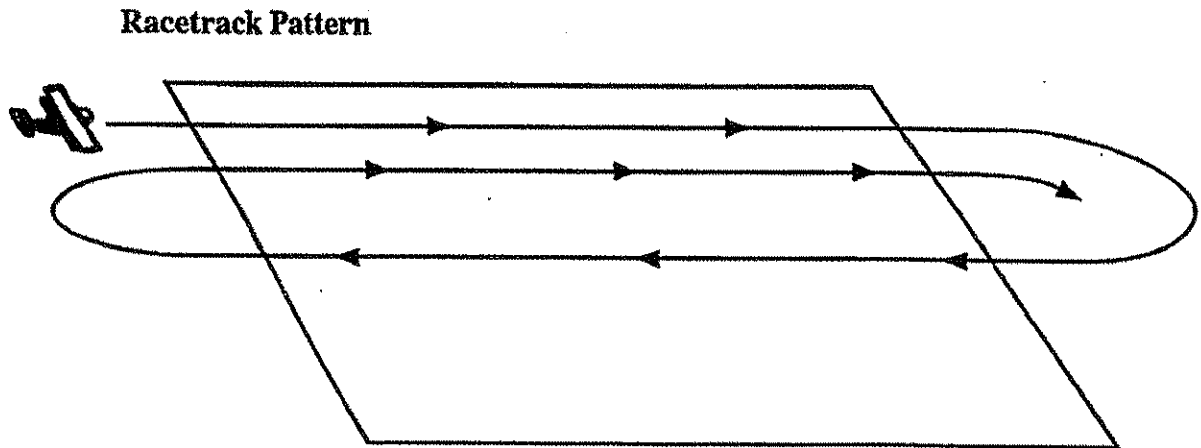

Figure 16

The racetrack pattern (Figure 16) is usually the most energy-efficient flight pattern. This pattern maximizes application time and minimizes turn times. Small fields may be flown in this manner or situations may exist where the race track pattern best allows the aircraft to avoid flight over sensitive areas.

## The Turnaround

When flying bidirectional swathing, the turnaround is an essential maneuver. Poorly executed turnarounds are a root cause of a considerable number of aerial application accidents. A pullup followed by a turn renders a low-speed, high-drag condition which must be carefully executed to avoid stall.

When approaching the end of a swath run, do not start a turnaround until after pulling up, clearing obstructions, and leveling off. Never look backward for orientation – instead always accomplish

swath exit orientation before pullup. After pullup, start the turnaround by turning 45° downwind. Level off for several seconds; then, turning into the wind, smoothly execute a coordinated reversal of 225° (see Figure 17.)

The number of seconds needed in level flight is largely governed by swath spacing, wind velocity (speed and direction), air density, altitude, and the aircraft's load, power, and maneuverability.

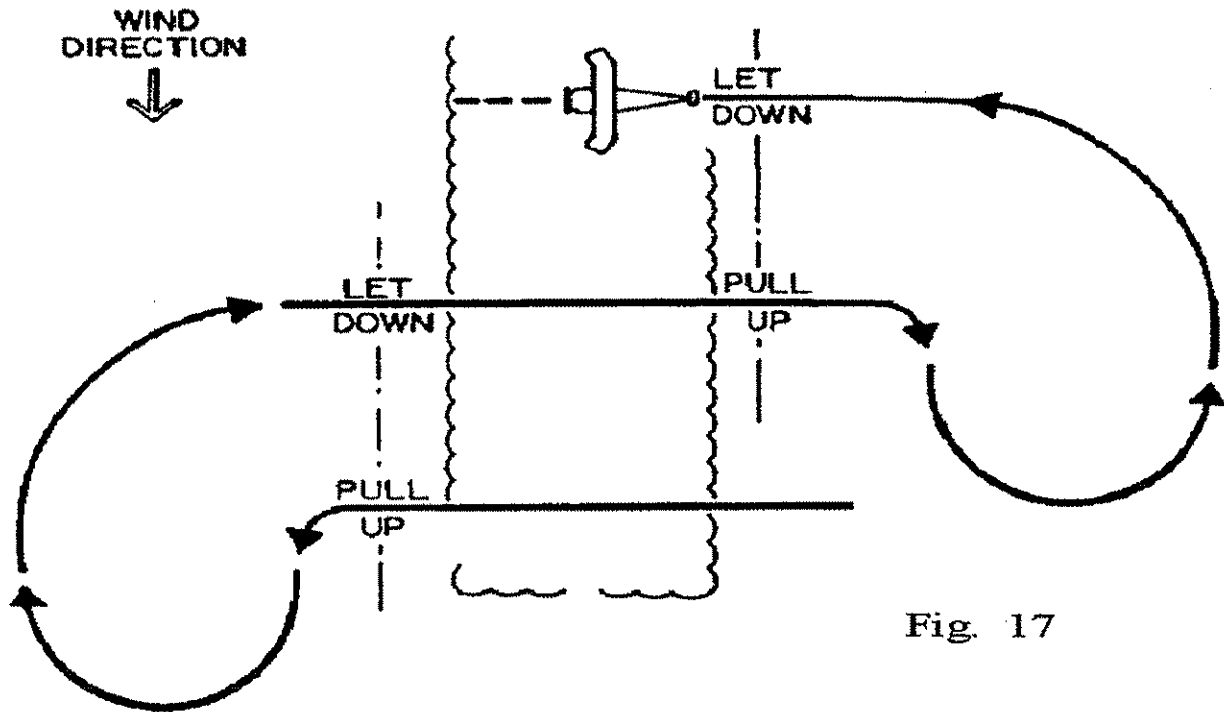

Fig. 17

Orient the aircraft for swath approach as the turnaround nears completion. This is the part of a turnaround that a pilot most often encounters difficulty. Attentiveness and careful timing during this stage of the turnaround are the keys to avoiding the hazards associated with fast or intricate maneuvering to accomplish swath approach. Always complete the turnaround before dropping in over any obstructions on swath approach.

Whenever possible, avoid making turnarounds over residences and other buildings, penned poultry or livestock, livestock watering places, ponds and reservoirs.

## Ferrying

For no reason greater than their mere presence (or noise and high visibility), agricultural aircraft are sometimes accused of damaging or contaminating property. Practicing good "ferry etiquette" can help an aerial applicator reduce such instances.

Whether loaded or empty, maintain a minimum flight altitude of 500 feet while ferrying between airstrip and target site. Never fly directly over farm buildings, residences, field workers, or sites

containing penned animals. For jobs that require repeated flights between airstrip and target site, it's best to fly a different route each trip. Deviating 1/8<sup>th</sup> to 1/4<sup>th</sup> mile from previous course is a simple way to avoid repeated flight over an area.

## Speed

As detailed in Chapter 7, the in-field performance of aerial pesticide dispersal apparatus is simply the rate at which the pesticide product and its carrier flows through the dispersal system (gallons per minute, pounds per minute, *etc.*) expressed in terms of the aircraft's productivity quotient (*i.e.*, acres treated per minute.) Thus, for "traditionally-outfitted" ag aircraft, (those not fitted with DGPS-mediated flow controllers) control of airspeed during aerial application is critical. For all traditionally-fitted craft, once the dispersal system has been calibrated, uniform site treatment can only be accomplished if the pilot constantly maintains correct airspeed during each swath run.

Agricultural aircraft fitted with an on-board DGPS signal processor linked to a flow controller can provide in-flight regulation of the dispersal system's output as a function of aircraft speed. This feature essentially "eliminates" the constraint of relying solely on speed for treatment uniformity.

## Application Height

Application height describes the distance between the nozzle tip (or spreader exit) and the target site (plant canopy.) Research findings indicate application height influences spray drift potential – regardless of the type of pesticide (*e.g.*, herbicide, fungicide, insecticide) being applied. *The variable most influencing application height is spray droplet size.* Results of spray drift management studies indicate that application height is best viewed as being directly proportional to spray droplet size. This means, to minimize drift risk, small droplet sprays require lower application heights. With larger spray droplets, application height can increase. As a "rule of thumb" – an application height of 8 - 10 feet is usually the *maximum* suitable for applying spray droplets that have 150 - 200  $\mu\text{m}$  diameters. For application heights greater than 8 - 10 feet, good drift minimization practice dictates using coarser (larger) spray droplets. As mentioned earlier, larger spray droplets generally diminish target site coverage – unless other calibration factors undergo alteration.

Due to their lower drift potentials, pesticides formulated as granules can generally be delivered from greater application heights than those suitable for sprays. Depending upon site conditions, suitable application heights for granular pesticide materials may range from 1/2 wingspan height to full wingspan height above the target site.

Arrange nozzles and adjust distributors to produce the desired deposit pattern with the material being applied from the application height you select. *Avoid using (or relying upon) application height as the principal means of adjusting either swath width or spray pattern uniformity.* Keep application height constant during each swath run to obtain uniform coverage of the target site.

## **Obstructions**

For safety and to prevent misapplication (skips, overdosing), handle areas around obstructions as follows:

### **Power and telephone lines**

Before starting spray operations, scout the target site from the air. First, circle the field at low altitude, keeping high enough to clear all readily-evident obstructions by at least 50 feet. Look for wires, poles, and other obstructions (trees, buildings, windmills, radio antennae, signs and billboards, pipeline markers, fences, farm equipment, etc.) both in and near the target site. Regard every break in cultivation pattern with suspicion. Note all obvious hazards. Communicate with on-site ground crew members to clarify any issues (however seemingly small) causing doubt.

After a preliminary scouting circuit, fly just above and along side of each power or phone wire and check each pole for *insulators, transformers and guy wires*. Wire is often hard to see from aloft; it's generally easier to see the insulators used as attachment points for pole-carried electrical wires. Transformers are often located on poles that support a branch wire leading to a house or other building.

Typically, guy wiring opposes the pull of circuitry wire. Thus, guy wire is normally located on the opposite side of a pole's wire burden. Guy wires also occur on poles where a main line makes a turn. Corner poles typically have two or more guy wires. Use radio communication with on-site ground crew members to confirm findings, resolve questions, and coordinate scouting effort.

#### **Remember:**

- Trees often obscure power and telephone lines.
- The wire you flew under last year (month, week, yesterday) may have a new one under it this year (month, week, today).
- The field you sprayed yesterday can have a new power (or phone) line in it today.
- Always determine the route by which any nearby building gets its electrical power. Almost invariably, an above-ground power line is coming in from somewhere!

### **Obstruction along side of field**

Within the limits of safe and prudent flight, fly close and parallel to the obstruction.

### **Obstructions at end of field**

Shut off the boom before initiating pull-up. Do so 1-2 swath widths before end of field. Failing to turn off the spray boom before initiating pull-up will cause a distorted spray deposition pattern. It will also promote spray drift. After turnaround, drop the plane in over the obstruction to application height at straight and level flight. Begin spray release only when even with the point where boom shutoff (prior to pull-up) occurred. After all parallel swaths are completed, fly 1-2

perpendicular swaths,( as needed) across the end of the field – making these parallel to the obstruction.

### **Obstruction within a field**

Approach a within-field tree, pole, or other obstruction in much the same way as you would one at the end of a field:

- Shut off the spray boom one or two swath widths before the obstruction.
- Pull up.
- If the terrain does not favor a straight path over the obstruction and subsequent let down, make a 360-degree turn before dropping in on the other side of the obstruction. (This allows you to control speed sufficiently to avoid overshooting the other side.)
- After working past a within-field obstruction, fly 1-2 perpendicular swaths on each side (*i.e.*, fore and aft) of it.

### **Deposit Pattern and Swath Spacing**

Use materials for swath checking that are as similar as possible to those to be applied to the target site. For example:

- Use dyed water to simulate water-based spray. Catch the dye-containing mix on paper cards or similar media. Thus, this procedure is best suited to **field-checks** of swath pattern uniformity. (Note: It is *extremely difficult* to reliably ascertain spray droplet *size* from viewing droplet stains on paper. Detailed spray pattern analyses are best conducted at boom setup and calibration – these topics form parts of Chapter 7.)
- Use the same basic procedure for swath checks of oil-based sprays. Alternatively, use oil-sensitive dyed cards instead of adding dye a spray oil.
- Do not confuse overall swath with *effective swath*. Overall swath is the total span of deposited spray (or granules) per flight pass. *Effective swath is the span containing sufficient deposit to obtain the desired results.* Typically, effective swath is rarely more than two-thirds of overall swath.
- Conduct in-field spray system tests during low wind conditions to determine the effective swath and suitable nozzle spacing. If field conditions include measurable wind, fly the aircraft directly into the wind to minimize wind-induced swath pattern effects.

- In the absence of wind, swath width increases with altitude until you reach a height approximately equal to wingspan. However, as application height (spray altitude) increases so does spray drift risk – unless spray droplet size is greatly increased. (Note: Large droplet sprays coarsen target site coverage. Such applications usually require higher gallons per acre to compensate for the coarsened coverage.)
- Water-based sprays on forest sites (insecticide applications) are often applied at (or near) wingspan height. Swath spacing in such cases is often two or more wingspans.
- The application height of oil-based insecticide sprays to forest sites is typically ½ of wingspan; in such cases, swath spacing is usually 1.5 - 2 wingspans.

## Ground Crews

Temporal and spatial constraints prevent an in-flight pilot from being able to perform various ground-based tasks – hence the need for a ground crew. Moreover, as a component of good safety practices, *an ag pilot should NOT participate in pesticide handling operations (e.g., mixing/loading, application equipment servicing, etc.) and thereafter proceed to fly an aircraft.* Instead, others should perform pesticide handling tasks.

Collectively, those who perform the various flight-support tasks that together enable the pilot to accomplish aerial application constitute the ground crew. Ideally, every ground crew member should be completely familiar with all facets of ground crew work – thus being able to work wherever need is greatest. However, because ground crew tasks typically have different demands and purposes, this manual artificially partitions the ground crew into four function-based subgroups:

- On-site Field Crew
- Pesticide Storage Crew
- Mixing/Loading Crew
- Equipment Servicing Crew.

## On-Site Field Crew

Collectively, the on-site field crew functions as an immediate extension of the pilot at work. To be maximally effective, each on-site field crew member should be able to communicate directly with the pilot – providing (as needed) site-specific details of current meteorological conditions, topographical features, location and dimension of ground-based hazards, buffer zone delineations, and similar matters.

In addition, duties of on-site field crew members typically include:

- Acting as liaison between pilot and client, to ensure aerial applicator obligations are met, *for example:*
  - 1) providing the client with the *pesticide application information* required by the *information exchange provisions of the Worker Protection Standard (WPS)*,

- 2) confirming that the client has properly posted the site (if so required by WPS.)
  - 3) **preventing** unauthorized persons (anyone other than members of the on-site field crew) from **entry or occupancy** of the site both immediately prior to and during application efforts. *Immediately* report any finding of unauthorized persons occupying the treatment site to both the pilot and the on-site field crew leader.
- Assisting the pilot in pre-treatment target site inspection.
  - Acting as in-field reference points for swath boundaries (*see Flag Crew, next section.*)
  - Providing emergency response to crash incidents (*see Aircraft Crash, end of chapter.*)

### Flag Crew

For various reasons (technological change, labor cost, regulatory influence, *etc.*), using on-site field crew personnel to provide reference points for landmark navigation at the target site has declined in recent years. Many flag crews have been replaced by either mechanical wing-mounted swath marking devices (weighted streamer dispensers, foam emitters, *etc.*) or on-board DGPS-mediated navigational devices. Notwithstanding these, human flag bearers are still sometimes the opted-for choice.

An on-site flag crew triggers the following rules:

- A) The pilot will not purposefully release pesticide while over flag crew members.
- B) Each member of the flag crew (regardless of task) must wear the PPE prescribed by the label(s) of the pesticide(s) being applied to the target site.

Additionally, flag crew members should:

- Never begin flagging without first **knowing the chemical product** being applied.
- **Avoid** settling pesticide spray, dust, or granules.
- Always begin flag operation from the downwind side of the target site, progressively relocating the swath margin boundary **into the wind** – never into spray drift.
- Avoid contact with spray during **calm** wind conditions;
- **Agree with the pilot beforehand** that you will flag one swath ahead of the spray pass.
- Watch the aircraft at all times. **Do not turn your back on an approaching aircraft.**
- **Be ready to move** to the next flag site **as soon as the aircraft is aligned** for a spray pass.
- Move ahead each time the aircraft approaches (keep the aircraft one swath behind.)
- **Never** flag while under power lines or near fences.  
(If the aircraft should cut or snag wires or fencing, trailing wire may seriously injure ground crew members.)
- **Never** direct the aircraft towards a guy wire.
- **Stay at the target site until the pilot has departed** – be ready to help if an accident occurs.

## Mixing/Loading Crew

*Pesticide handling occurs whenever the potential for chemical exposure is imminent (i.e., the lid is off the container, the diluted product is in motion, etc.)* All pesticides (herbicides, fungicides, insecticides, nematicides, miticides, etc.) should be handled only in strict accordance with their labels' directions for use. Thus, every ground crew member who handles a pesticide product (e.g., preparing spray mix, loading hoppers, etc.) must:

- Wear all articles of *personal protective equipment (PPE)* indicated by the pesticide product label as PPE required for that task. Every pesticide label specifies such information – disregarding (or incompletely complying with) pesticide label directions violates federal and state law.
- Ensure the PPE articles (provided by the certified applicator) are correct, clean, and serviceable. Noting especially:
  - a) To wear a respirator whenever the pesticide label indicates to do so. Use the respirator filter specified for the chemical being handled. Ensure the filters and pre-filters are serviceable. Conduct a respirator fit check before starting work.
  - b) Sweaty hands absorb pesticide more readily than do dry hands. Rubberized gloves *cause* hands to sweat. When using nitrile (or other types of rubberized) gloves, keep the inside of the gloves free of pesticide. Never remove gloves to increase manual dexterity during a pesticide-handling task (e.g., removing a container lid) and thereafter put potentially-pesticide-soiled hands back into the gloves.
  - c) Always *wash and dry your hands before putting on* rubberized gloves.
  - d) Always *wash the outside of rubberized gloves before removing* them.
- After use, clean all PPE and store it where it will not be damaged or contaminated.
- Be aware of and follow the procedural tasks that together constitute safe handling practices for the pesticide being handled.
- Be familiar with the typical signs and symptoms of poisoning caused by overexposure to the pesticide being handled.
- Know how to perform the first aid measures appropriate for victims of overexposure to the pesticide being handled.



As its task name (mixing/loading) indicates, pesticide handling tasks of an aerial application mix/load crew basically entail:

- a) combining a desired amount of one or more formulated pesticide products (perhaps with adjuvants, *etc.*) with a measured amount of diluent (usually water),
- b) thoroughly rinsing any pesticide product container emptied during spray preparation and using the container rinsate as part of the spray mix's diluent,
- c) putting the resulting spray mix into the aircraft's hopper, and
- d) doing these things in a manner that simultaneously satisfies the following five performance-based objectives:
  - i) *enables a work efficiency* that is adequate for commercial operation,
  - ii) offers safeguards that *minimize the likelihood of pesticide overexposure* occurring to any mix/load crew member,
  - iii) *fulfills the mix/load directions stated on the pesticide label* of the product being handled,
  - iv) *protects the local environment* from chemical contamination ever becoming an environmental consequence of pesticide handling activity, and
  - v) *satisfies all regulatory constraints* imposed by local, state and federal authorities governing pesticide mixing/loading operations.

At present, a “universal aerial application mix/load rig” (either closed-system or otherwise) that fully satisfies the day-to-day operational needs of every aerial applicator **does not exist**. Instead, tailored assemblages of pesticide handling equipment – configured to accommodate the specific mix/load needs of an individual aerial applicator (and any locally-imposed regulatory constraints) – typically accomplish the mix/load tasks of aerial application operations.

Some “necessary differences” in aerial mix/load site equipment arise from physical characteristics of pesticide product containers. For example, mix/load operations that obtain concentrated pesticide products from small plastic containers have significantly different equipment needs (for both container emptying, container rinsing, and management of rinsed containers) than do operations which get pesticide concentrates from larger (e.g., barrel, mini-bulk, or bulk-storage) containers.

“Necessary differences” also arise in mix/load facility design. The dominant factors influencing mix/load facility design differences are:

- **climate** (structural needs dictated by prevailing winds, average annual rainfall, *etc.*),
- **locale** (proximity to surface water, water courses, groundwater, *etc.*),
- **operational scope** (numbers and kinds of ag chemicals handled,) and
- **locally-implemented regulation** (state and local government’s rules.)

Because great variation in specific features is a *de facto* norm of aerial application mix/load sites, ***the best general standard for an applicator wanting to assess his/her aerial mix/load site is a performance-based standard.*** Thus, regarding mix/load site design details, the aerial applicator should always ask (and answer) the question:

**“Is my proposed solution to this particular mix/load site problem a good way to solve that problem?”**

Thereafter, the acid test for evaluating the goodness of any particular mix/load site component (material, dimension, equipment, work practice, facility design, facility siting, *etc.*) is to judge it in the light of the **five performance-based objectives (i - v) presented earlier under item “d”** (*see page 144.*)

### **Equipment Servicing Crew**

These ground crew members maintain the work readiness of aerial application equipment. Their tasks include:

- A) ***fitting*** new components to an aircraft’s pesticide dispersal system;
- B) ***preparing*** used components of an aircraft’s pesticide dispersal system for re-use;
- C) ***removing, installing, testing, or adjusting*** existing components of an aircraft’s pesticide dispersal system;
- D) ***cleaning*** an aircraft’s exterior (*e.g.*, wings, landing gear, fuselage, empennage, *etc.*) following aerial application work.

Most components (pumps, check valves, nozzle bodies, spray tips, *etc.*) of a pesticide dispersal system used in aerial application are designed for repeated usage. Consequently, a service crew member's work often involves handling pesticide-contaminated mechanical parts. In all such instances, the service crew member is a pesticide handler until the parts are cleaned and the cleaning medium (wash water) is managed in accordance with the dictates of local governance.

Service crew members who handle pesticide-contaminated application equipment components **must:**

- be familiar with the label-imposed requirements of the pesticide product(s) most recently used in the application equipment, noting especially the personal protective equipment (PPE) requirements for pesticide handlers, and the first aid actions to take in the event of an accident; and
- wear all articles of PPE prescribed for handler protection by the pesticide label(s).

After cleaning pesticide-contaminated application equipment, servicing his or her PPE articles, and managing the resultant wash waters, the service crew member should maintain personal hygiene by showering thoroughly and changing into clean clothing.

If a service crew member's work clothing becomes contaminated with pesticide during application equipment cleaning, he or she should immediately:

- stop work,
- remove the soiled article(s) of clothing and set them aside,
- wash the affected skin thoroughly with soap and water,
- dry with clean towel(s), and
- change into clean clothing.

Thereafter, resume the work task. Regardless of perceived work urgency or other circumstance, service crew members should *never continue to wear pesticide-contaminated clothing*.

### **Steam cleaning**

Even under "normal" circumstances, steam cleaning offers hazard (*e.g.*, potential for burn injury) sufficient to merit particular operator attentiveness and safety awareness. Using steam to clean the exterior of aerial application equipment typically compounds that hazard. This is mainly because the chemical constituents (active ingredients, inerts, diluents, carriers, *etc.*) of many formulated pesticides vaporize at (or beneath) the threshold temperature of steam (212 F°).

Steam cleaning can cause job-site *creation* of a pesticidal vapor. Often, the vapor of a substance has high local mobility (in the surrounding air), is less readily detected (by other nearby members

of the service crew), and is more readily absorbed (by humans), than is the same substance in liquid or solid form..

In addition, producing vaporized pesticide chemical during equipment cleaning typically increases the need for cleanup crew members to take additional safety measures (needing to use more or different PPE, altering normal work methods, modifying the work facility, *etc.*)

For these reasons, the use of live steam is *a poor choice for initial external cleaning* of aerial equipment that has newly returned from pesticide application work. The better choice is to use a two-staged equipment cleaning procedure:

- 1) **prep-clean** the equipment by applying a low pressure (10-25 psi) flooding rinse of clean water – the object is to thoroughly flush (with minimal splash) all external surfaces suspected of pesticide contamination.
- 2) **Service-wash** the equipment (via power washer, wanded brush, steam jenny, *etc.*)

Other practical matters relating to washing an pesticide-soiled ag aircraft include:

- Verifying the equipment clean-up facility (or area) is well ventilated.
- Having enough hose available to easily reach all external surfaces of entire aircraft.
- Conducting a preliminary low-pressure rinse of the aircraft's entire undersurfaces.
- Working from undercarrige upward, rinse all external surfaces of the aircraft.
- Avoiding direct contact with steam, splash, and vapors generated during equipment cleaning.

## **Aircraft Crash Response**

In most instances, crashes are not scheduled events. Therefore, from the moment the aircraft first departs the mix/load site until its final return at the workday's end, every member of the ground crew (regardless of his or her assigned duty) should remain prepared to immediately respond to an aircraft crash.

The *first thought* of every respondent to an aircraft crash should always be to act promptly, stay calm, and focus on helping the pilot. Somewhat relatedly, the respondent's *first action* should be to *get the fire extinguisher (whether or not fire is visible) and immediately go to the crash site*. As soon as possible, inform the ground crew leader of the crash site's exact location.

If the plane is **on fire**:

- stay out of the smoke. Use the fire extinguisher to help get the pilot out and move him to safety, upwind and up-slope of the wreckage.
- Check the pilot and his clothing to see if he has been splashed with pesticide. If so, and he is not seriously injured, remove all pesticide-contaminated clothing, help him to the nearest water and wash several times. Use soap, if available.
- If the pilot appears seriously injured, loosen any restrictive clothing, ensure his airway is clear, and use direct pressure to stop any profuse bleeding. Thereafter, either take the pilot to a medical facility, or call an ambulance. Tell the medical authorities what pesticide was being used. Be sure to provide the attending medical authorities with a copy of the pesticide label.

If the plane is **not on fire**:

- If the pilot is not seriously injured, take him to a hospital or doctor for checkup. Inform the medical authorities of the pesticide that was being applied and provide them a copy of the pesticide label.
- If the pilot is seriously injured or unconscious, **do not move him** from the plane. Check to see if he is strangling or choking. Remove any restrictive clothing and make sure his airway is clear. Check for bleeding. If an artery is cut (spurting blood), apply direct pressure to restrict the bleeding. Apply a tourniquet only as a last resort, life-saving, measure.
- Go (or send another to) telephone for ambulance or doctor. Be sure to clearly identify and communicate your location and the type of accident that has occurred.
- After an ambulance is *en route*, contact the pilot's main operations office, state what has happened, and identify the hospital or health care facility receiving the pilot.
- Go with the ambulance to the health care facility and make certain that the health care providers know exactly which pesticide the pilot was applying. Provide a copy of the label of the pesticide product to the attending physician or his/her direct representative.

# Review Questions for Chapter 11

(Answers: page 197)

01. Fatigue management tactics for pilots include sufficient sleep, proper diet, periodic breaks, and realistic workloads and timetables.

**True**

**False**

{text: Ch11; p 171}

Comment: \_\_\_\_\_  
\_\_\_\_\_

02. A good ag pilot should never refuse a customer's request for spray service at a specific time – after all, it's the customer's field that's being treated.

**True**

**False**

{text: Ch11; p 172}

Comment: \_\_\_\_\_  
\_\_\_\_\_

03. Strictly speaking, the site owner (or his agent requesting the work) bears the foremost responsibility for the decision to actually perform the pesticide application.

**True**

**False**

{text: Ch11; p 172}

Comment: \_\_\_\_\_  
\_\_\_\_\_

04. During ferry flights, the best policy is to rapidly fly the most direct heading possible across any sensitive area situated between the mix/load site and the target site.

**True**

**False**

{text: Ch11; p 172}

Comment: \_\_\_\_\_  
\_\_\_\_\_

## Review Questions for Chapter 11

(Answers: page 197)

05. Personal hygiene has very little influence on the likelihood of illness resulting from pesticide overexposure.

**True**

**False**

{text: Ch11; p 172}

Comment: \_\_\_\_\_  
\_\_\_\_\_

06. The only purpose for flying an inspection pass upon arrival at a target site is to minimize the likelihood of treating the wrong site.

**True**

**False**

{text: Ch11; p 172}

Comment: \_\_\_\_\_  
\_\_\_\_\_

07. Whenever the target site consists of hilly terrain, all spray passes should be flown up-slope if the surrounding topography does not permit contour flying.

**True**

**False**

{text: Ch11; p 173}

Comment: \_\_\_\_\_  
\_\_\_\_\_

08. In most cases, flying a racetrack pattern is more energy efficient than flying bidirectional swaths.

**True**

**False**

{text: Ch11; p 173}

Comment: \_\_\_\_\_  
\_\_\_\_\_

## Review Questions for Chapter 11

(Answers: page 197)

09. Whenever possible, swaths should be flown crosswind and progress successively downwind.

**True**

**False**

{text: Ch11; p 173}

Comment: \_\_\_\_\_  
\_\_\_\_\_

10. Without exception, a change in aircraft speed during a swath run always alters the actual spray volume rate (gpa) at the target site.

**True**

**False**

{text: Ch11; p 175}

Comment: \_\_\_\_\_  
\_\_\_\_\_

11. In most cases, actual travel speed is the variable most influencing application height.

**True**

**False**

{text: Ch11; p 175}

Comment: \_\_\_\_\_  
\_\_\_\_\_

12. Whenever application height is purposefully increased, intended spray droplet diameter should be purposefully (and proportionally) decreased.

**True**

**False**

{text: Ch11; p 175}

Comment: \_\_\_\_\_  
\_\_\_\_\_



## Review Questions for Chapter 11

(Answers: page 198)

13. Except under conditions of excessively gusty crosswind, effective swath and overall swath will have essentially equal dimensions.

**True**

**False**

{text: Ch11; p 177}

Comment: \_\_\_\_\_  
\_\_\_\_\_

14. To both demonstrate safe handling procedure to new workers and establish the importance of teamwork, the pilot should actively assist mix/load operations as often as possible.

**True**

**False**

{text: Ch11; p 178}

Comment: \_\_\_\_\_  
\_\_\_\_\_

15. As a rule, each ground crew member should be exclusively trained in one task, preferably to the point of being able to do that task flawlessly.

**True**

**False**

{text: Ch11; p 178}

Comment: \_\_\_\_\_  
\_\_\_\_\_

16. A flag crew member should not move to the next flag site until after the pilot activates the boom for the current spray pass.

**True**

**False**

{text: Ch11; p 179}

Comment: \_\_\_\_\_  
\_\_\_\_\_

## Review Questions for Chapter 11

(Answers: page 198)

17. All members of the on-site field crew should remain alert and present at the target site until the pilot departs.

**True**

**False**

{text: Ch11; p 179}

Comment: \_\_\_\_\_  
\_\_\_\_\_

18. The only members of the ground crew that *must* wear the personal protective equipment (PPE) specified by the pesticide label are those who actually handle open containers of pesticide during mixing/loading.

**True**

**False**

{text: Ch11; p 179,180,183}

Comment: \_\_\_\_\_  
\_\_\_\_\_

19. Climate, locale, operational scope, and locally-implemented regulation are the dominant factors influencing mix/load facility design.

**True**

**False**

{text: Ch11; p 182}

Comment: \_\_\_\_\_  
\_\_\_\_\_

20. Any ground crew member who services pesticide-contaminated mechanical parts (pumps, nozzle tips, etc.) on an agricultural aircraft is a pesticide handler.

**True**

**False**

{text: Ch11; p 183}

Comment: \_\_\_\_\_  
\_\_\_\_\_

## Review Questions for Chapter 11

(Answers: page 198)

21. The first action of any ground crew member responding to an aircraft crash should be to put on all of the personal protective equipment specified by the label of the pesticide loaded on the aircraft.

**True**

**False**

{text: Ch11; p 184}

Comment: \_\_\_\_\_  
\_\_\_\_\_

22. For an aircraft on fire, the preferable place for detailed first aid actions on a pilot who has been removed from a crashed aircraft is upwind and up-slope of the wreckage.

**True**

**False**

{text: Ch11; p 185}

Comment: \_\_\_\_\_  
\_\_\_\_\_

23. Unless the pilot was seriously drenched by spray mix leaking from a crashed aircraft, telling health care providers exactly which pesticide was being applied is an unimportant detail.

**True**

**False**

{text: Ch11; p 185}

Comment: \_\_\_\_\_  
\_\_\_\_\_

## *Notes*

---

# Answers to Review Questions

## Chapter 1 – Regulations

01. False (includes fertilizers, seeding, etc.)
02. False (contact: US Gov. Printing Ofc.)
03. True
04. False (valid until surrendered, suspended or revoked.)
05. False (only the ag aircraft operator certificate needs to be carried.)
06. False (14CFR137.37 specifies *how* any pesticide must be dispensed.)
07. True
08. False (14CFR137.49 enables close-in flight and maneuver.)
09. False (40 CFR (*EPA regs.*) and state-specific rules govern these.)
10. True
11. False (The more stringent law prevails.)
12. False (Manufacturers often find it necessary to alter label language.)

## Chapter 2 – Pesticides and Human Health

01. False (No derivative group is intrinsically more benign (“safer”) than another.)
02. True
03. False (Differences in skin texture and structure cause absorption differentials.)
04. True
05. True
06. True
07. False (The lower the number the higher the toxicity.)
08. True
09. False (Signs and symptoms of poisoning are dosage (or dose-interval) dependent.)
10. True
11. False (Feelings are *symptoms*, not signs.)
12. False (Signs are visible to others; symptoms are manifest only to the victim.)
13. False (Cholinesterase testing is not obligatory – instead, *may wish to* participate.)
14. True
15. False (Apply no first aid medication – instead, flush with clean water and pat dry.)
16. False (Do not immediately induce vomiting – instead, contact a medical authority.)

## Chapter 3 – Application Equipment

01. True
02. False (Gear pumps deliver low flow rates but can work against high pressure.)
03. True
04. False (Valves that *have* a tank return passage reduce post-shutoff boom pressure.)
05. False (Spray mix viscosity is often different than that of pure water.)

# Answers to Review Questions

## Chapter 3 – Application Equipment (con'd)

06. False (An airfoil-shaped boom produces the least drag.)
07. True
08. False (Boom length of rotary-wing craft should not exceed 80% of rotor diameter.)
09. False (Fan nozzles typically produce fewer driftable droplets than do cone nozzles.)
10. False (This describes a rotary nozzle – not a CP nozzle.)
11. False (Typically, needle and seat valves are *less* labor intensive to clear – not more.)
12. False (Typically, *maximum* ejection is 35 pounds per second – more risks choking.)
13. False (Hinged gates usually require adjustment *more frequently* than sliding hatches.)
14. False (Feed gate setting uniformity is *more critical* at lower application rates.)
15. False (Greatly increasing feed gate setting enhances the risk of choking the spreader.)
16. True
17. True
18. False (Decreasing spacing between adjacent vanes decreases air volume in that duct.)
19. True
20. False (Increasing hopper feed rate *decreases* a ram-air spreader's swath width.)

## Chapter 4 – Drift Management

01. False (Spray drift only occurs downwind – by definition, drift is airborne movement.)
02. True
03. False (Most spray drift consists of droplets having diameters less than 150 microns.)
04. True
05. True
06. True
07. True
08. False (In general, the narrower spray angle generates the fewer driftable droplets.)
09. True
10. True
11. True
12. True
13. False (Invert emulsions yield larger droplets – which typically give poorer coverage unless spray volume rate (gpa) is increased.)
14. False (Decreased surface tension increases droplet evaporation – which decreases droplet size, thus making the droplet more drift prone.)
15. True
16. True
17. True
18. True
19. False (As RH increases, drift potential decreases – due to less evaporation potential.)
20. True

# Answers to Review Questions

## Chapter 5 – Navigation

01. False (Landmark navigation is practiced by ag pilots using DGPS equipment.)
02. False (Typically, LORAN gives less precise positioning than does DGPS.)
03. True
04. True
05. False (C/A signal data are in the public domain – available without charge to all users.)
06. True
07. True
08. True
09. False (US Coast Guard beacons supply DGPS correction data free of charge.)
10. True
11. False (WAAS data are too imprecise for most ag pilot uses.)
12. False (In general, OmniSTAR data provide users with better positional accuracy.)
13. False (The “basic set” for ag aircraft must also include a lightbar.)
14. False. (The in-cabin lightbar should be located in the pilot’s peripheral vision field.)
15. False (Over-reliance on the lightbar will likely reduce overall flight safety – instead, to improve flight safety, it’s better to “keep you head outside the aircraft.”)
16. True

## Chapter 6 - Calculating the Area of a Target Site

01.  $A=lw$
02. radius =  $d/2 = 0.4\text{mi}/2 = 0.2 \text{ mi.}$   
Area =  $\pi r^2 = 3.14(0.2)^2 = 0.1256 \text{ sq.mi.}$   
Acreage =  $(0.1256 \text{ sq.mi.}) \times (640 \text{ Acres/sq.mi.}) = 80.38 \text{ Acres}$
03. Area =  $(bh)/2 = ((990 \text{ ft.}) \times (670 \text{ ft.})) / 2 = 331,650 \text{ sq.ft.}$   
Acreage =  $(331,650 \text{ sq.ft.}) \times (1 \text{ Acre}/ 43,560 \text{ sq.ft.}) = 7.61 \text{ Acres}$

## Chapter 7 - Calibration Procedures

01. True
02. False (If the contracting client grants approval, a pilot may apply at less than the lowest label rate – provided the pesticide label doesn’t prohibit doing so.)
03. False (Boom discharge rate is expressed in gallons per *minute*.)
04. False (Treatment progress rate is expressed in *acres* per minute.)
05. True
06. True
07. True

## Answers to Review Questions

### Chapter 7 - Calibration Procedures (con'd)

08. False (Boom discharge rate is directly influenced by *three* things: *nozzle tip size*, *at-nozzle spray pressure*, and *number of nozzles on boom*.)
09. False (Treatment progress rate is directly influenced by swath width and speed.)
10. True
11. True
12. True
13. True
14. True
15. True
16. True

### Chapter 8: Pesticide Measurement Systems

01. False (Typically, label directions for dilution rates and spray volume rates are expressed in units of U.S. Measurement.)
02. True
03. False (One ounce [US Weight] bears no relation to one fluid ounce [US Liquid Measure]. These measure different things and employ different scalar values.)
04. False. (Volume denotes the three-dimensional space occupied by an object. Hence, its basic unit must express *cubic* dimensionality – i.e., *cubic inch*.)
05. False (Area denotes the two-dimensional space present on a surface. Hence, its basic unit must express *squared* dimensionality – i.e., *square inch*.)
06. False (These are measures of different things; area and volume, respectively. Although superficially similar, values for *acre* and *acre-foot* are dimensionally different.)
07. True
08. True

### Chapter 9: Using a Dry Formulation to Prepare a Spray

01. True
02. False (*All* of the active ingredient in an SP is water soluble; the *90* indicates what *proportion* of the formulation consists of active ingredient.)
03. True
04. False (No conversion needed – when the label indicates the amount of *product* to use, often the largest question remaining is, “How much spray mix is required for the job?”)
05. True
06. False  $\text{lbs. Product Needed} = (0.2 \text{ lb./Ac.}) \times (30 \text{ Ac.}) = 6 \text{ lb.}$  {*qed., NOT 3lb.*}
07. True
08. False  $\text{lbs. Product/Acre} = (0.25 \text{ lb.ai./Ac.}) \times [(100 \text{ lb. product})/(50 \text{ lb.ai.})]$   
 $= 0.5 \text{ lb./Acre}$  {*qed., NOT 2 lb/Ac.*}



## Answers to Review Questions

### Chapter 9: Using a Dry Formulation to Prepare a Spray (con'd)

- 09. True
- 10. False (The expression, "relative weight of the active ingredient" is nonsensical.)
- 11. False A 90SP is a water-soluble powder; 90% of which, is active ingredient.

### Chapter 10: Using a Liquid Formulation to Prepare a Spray

- 01. True
- 02. True
- 03. True
- 04. False (No conversion needed – when the label indicates the amount of *product* to use, often the largest question remaining is, "How much spray mix is required for the job?")
- 05. True
- 06. True
- 07. True
- 08. True
- 09. True
- 10. False (The expression, "relative weight of the active ingredient" is nonsensical.)
- 11. False (A 90SL is a water-soluble powder; 90% of which, is active ingredient.)

### Chapter 11: Operations

- 01. True
- 02. False (A pilot should always be prepared to refuse a customer service at a particular time – if current conditions promote unwarranted safety hazards or other risks.)
- 03. False (The ag pilot bears the foremost burden of responsibility for the application decision – after all, the pilot is the one who actually flies the plane and activates the boom.)
- 04. False (The best policy is to fly around, rather than directly over, sensitive areas.)
- 05. False (Personal cleanliness helps reduce the likelihood of pesticide-induced illness.)
- 06. False (Pre-treatment site inspection has many purposes – site id is only one of them.)
- 07. False (When contour flying is not possible, in hilly terrain, passes should be flown down-slope – flying up-slope enhances crash risk.)
- 08. True
- 09. False (Swaths should be flown crosswind and progress successively upwind.)
- 10. False (Spray craft fitted with a DGPS-mediated flow-controller can maintain a desired spray volume rate (gpa) even when treatment progress rate fluctuates.)
- 11. False (Usually, spray droplet size is the factor most influencing application height.)
- 12. False If application height is increased, spray droplet size should also be increased.
- 13. False Typically, effective swath is less than overall swath.

## Answers to Review Questions

### Chapter 11: Operations (con'd)

14. False (A pilot should not perform mix/load tasks -- and thereafter fly that load.)
15. False (Ideally, each ground crew member should be able to perform any ground crew task.)
16. False (A flagger should move ahead to the next flag site as soon as the pilot is lined up for the current pass.)
17. True
18. False (In-field members of the flag crew must wear the PPE specified by the product label(s) of the pesticide(s) being applied during flag operation.)
19. True
20. True
21. False (The first action of any ground crew member responding to an aircraft crash should be to *get the fire extinguisher and immediately go to the crash site.*)
22. True
23. False (Whenever a pilot is taken to a health care facility after an aircraft crash, the attending medical authorities should be both *told about and provided copies of the labels* of the pesticides that were being applied by the crashed aircraft.)