



# Sampling Animal Manure

Richard D. Coffey, Gary R. Parker, and Kevin M. Laurent, Department of Animal Sciences;  
Doug G. Overhults, Department of Biosystems and Agricultural Engineering

Animal manure is an excellent fertilizer for crops and forages. Manure contains nitrogen, phosphate, potash, and micronutrients that are essential for plant growth. Also, applying manure to land can improve soil tilth, increase water-holding capacity, reduce water and wind erosion, improve aeration, and promote beneficial organisms. Because of these benefits, a majority of manure nutrients produced by Kentucky's livestock and poultry are recycled to the land.

Average manure nutrient content values (book values) provide estimates that can be used for planning purposes. However, manure nutrient concentrations can vary widely among different farms. Factors that influence the nutrient content of manure include animal species, size and number of animals housed, diet composition, feed efficiency, type of manure storage, and manure management factors (frequency of building cleanout, frequency of flushing pits, storage time, amount of water or bedding added to manure, etc.). The unpredictability of nutrient content makes nutrient testing of manure a critical part of a sound manure management plan. This publication provides some guidelines to use when sampling animal manure for laboratory analysis.

## When to Sample Animal Manure

To ensure adequate time for a laboratory to complete an analysis and determine manure application rates, you should sample manure within 30 to 60 days of the date you plan to apply it. Nutrient levels in manure storage structures typically do not change rapidly, and an elapsed time of a few weeks between sampling and application is not likely to be critical. Seasonal variations do occur, however, and it is best not to use a manure analysis obtained in the spring for applications in the fall. A manure analysis should be obtained each year.

If it is not possible to obtain an analysis before the manure is applied, you can sample the manure just before or while spreading it. You can use nutrient estimates or historical analysis results to determine an application rate that is not likely to provide an excessive amount of nutrients. Additional nutrients, from manure or chemical fertilizer, can be applied later if the test results show they are needed.

## Techniques for Sampling Different Types of Manure

The accuracy of a manure nutrient analysis is only as accurate as the sample sent to the lab. You must collect a sample that is representative of the entire batch of manure being tested. The following sampling techniques for various types of manure will help ensure that you obtain the best possible analysis.

### Sampling Manure Slurries from Slotted-Floor Pits

Many swine production facilities use slotted floors over a pit to collect and store manure until application. As manure collects in a pit, solids settle toward the bottom of the pit, and nutrients stratify into layers of varying nutrient content. Because of this stratification, before samples are taken, the pit contents should be mixed (or agitated) for 2 to 4 hours to ensure that a representative sample is obtained. It is very important to use adequate ventilation when agitating slotted-floor pits.

Equipment needed to collect samples from an under-slat pit includes: (1) a composite sampling device such as the one shown in Figure 1, (2) a 5-gallon plastic bucket (do not use galvanized containers because metals in the container such as zinc may contaminate the sample), and (3) a clean, 1-quart, widemouthed plastic bottle with a screw-type lid. NEVER USE A GLASS CONTAINER FOR SAMPLES.

Approximately 10 to 12 subsamples should be taken from different locations throughout the pit. To obtain the subsamples, lower the composite sampling device through the slots until

Figure 1. An example of a composite sampling device for sampling manure from slotted-floor pits.

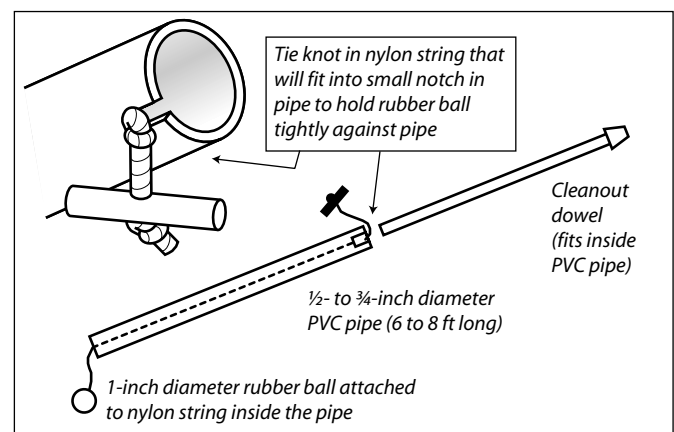

you feel the bottom of the pit. Then, pull the nylon string running through the interior of the composite sampling device until the rubber ball seals against the bottom of the PVC pipe. Remove the sampling device from the pit, and empty the entire contents into the plastic bucket.

After all subsamples have been collected, swirl or mix the slurry in the bucket, and pour the composite sample into the plastic bottle. Fill the plastic bottle no more than two-thirds full to allow room for expansion caused by the release of gas from the liquid manure sample. Be sure to tighten the lid to prevent the sample from leaking during delivery to the testing lab. Refrigerate or freeze samples that cannot be shipped or delivered to the testing lab on the day of collection.

**Sampling Manure Slurries from Earthen Storage Basins (Holding Ponds) and Aboveground Tanks**

Manure stored in earthen basins and aboveground tanks is similar to that stored in under-slat pits in that the solids settle and nutrients tend to stratify in storage. Manure in these storage structures should be thoroughly agitated before taking the sample.

The equipment needed to collect samples from storage basins and tanks includes: (1) a composite sampling device such as the one shown in Figure 2, (2) a 5-gallon plastic bucket, and (3) a clean, 1-quart, widemouthed plastic bottle with a screw-type lid.

About 10 to 12 subsamples from different locations around the basin or tank should be collected. To collect subsamples, lower the full length of the composite sampling device (or to within the bottom foot of the storage structure) into the manure slurry, and then pull the nylon string attached to the rubber ball to seal the slurry within the sampling device. Remove the sampling device, and empty the contents into the 5-gallon bucket. After all subsamples have been collected in the bucket, thoroughly mix the slurry in the bucket. Fill the plastic bottle no more than two-thirds full with the composite sample. Securely tighten the lid on the bottle to prevent the sample from leaking.

**Sampling Manure Effluent from Lagoons**

The nutrient content of lagoon effluent may vary from the top layer to the bottom layer. Obtaining a representative sample from lagoons is difficult and requires collecting subsamples to the depth from which the effluent will be applied. For example, if effluent is pumped only from the top layer of the lagoon without any agitation, you need to sample only from that portion that is to be pumped. If a lagoon will be agitated when it is pumped, it is best to sample from the fully mixed lagoon or to take several subsamples on the discharge side of the pump. Producers with multistage systems should collect samples from the lagoon that will be pumped for land application. Two methods that can be used to sample lagoon effluent—the pole and cup method and the composite (or profile) method—are described below.

Figure 2. An example of a composite sampling device for sampling manure from earthen basins and aboveground tanks.

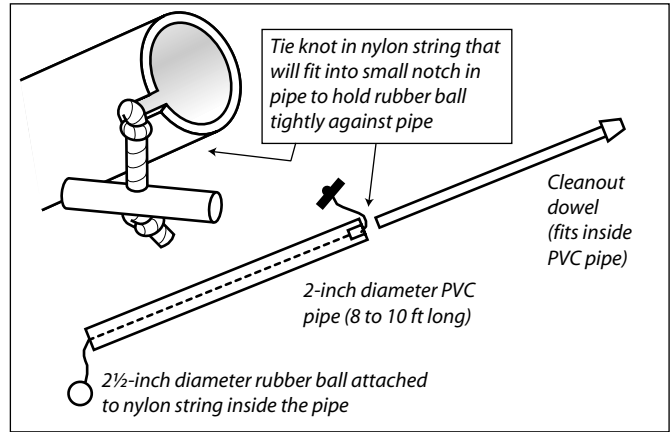
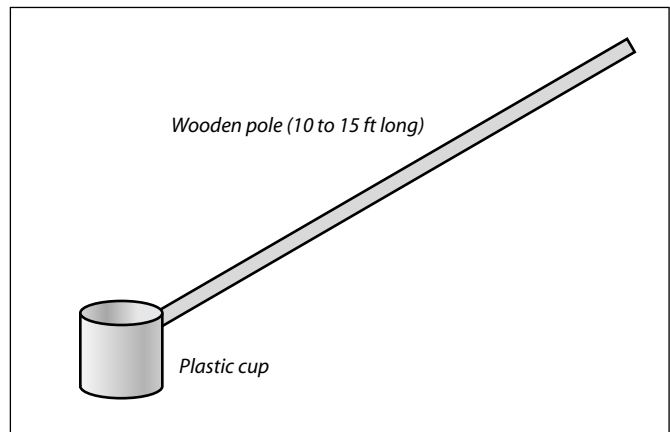

Figure 3. An example of a pole and cup sampling device for sampling manure effluent from lagoons.



**Pole and Cup Method**

The equipment needed to sample lagoons using the pole and cup method includes: (1) a pole and cup liquid manure sampling device such as the one shown in Figure 3, (2) a 5-gallon plastic bucket, and (3) a clean, 1-quart, widemouthed plastic bottle with a screw-type lid.

Using the pole and cup sampling device, collect 10 to 12 subsamples by extending the sampling device the length of the pole toward the center of the lagoon, and dip a cupful of lagoon effluent. Do not collect solids, floating debris, or scum with the subsample. Each of the subsamples should be taken from different locations around the lagoon. As each subsample is collected, pour the contents into the 5-gallon plastic bucket. After all subsamples have been collected, thoroughly mix the contents in the bucket. Fill the plastic bottle about two-thirds full with the composite sample. Securely tighten the lid to prevent the sample from leaking.

### Composite (or profile) method

The composite (or profile) method of sampling allows subsamples to be taken from the full depth of the lagoon. The equipment needed for this sampling method includes: (1) a composite sampling device such as the one shown in Figure 4, (2) a 5-gallon plastic bucket, and (3) a clean, 1-quart, widemouthed plastic bottle with a screw-type lid.

Approximately 10 to 12 subsamples taken from different spots in the lagoon are needed to obtain a representative sample. Ideally, a small boat that could be paddled into the lagoon would be used to collect samples away from the edges. To collect subsamples, lower the full length of the composite sampling device into the lagoon, or lower the device until it reaches the bottom of the lagoon (be careful not to plug the end of the sampling device with sludge at the bottom of the lagoon). Then, pull the nylon string running through the interior of the composite sampling device until the rubber ball seals against the bottom of the PVC pipe. Remove the sampling device from the lagoon, and empty the entire contents into the plastic bucket.

After all subsamples have been collected in the bucket, thoroughly swirl or mix the effluent. Fill the plastic bottle no more than two-thirds full with the composite sample. Securely fit the lid on the bottle to prevent the sample from leaking.

### Sampling Dry Manure Stacks or Litter Piles

Solid (dry) manure and poultry litter is often stored outside in a stack pad, horizontal concrete silo located above ground, or litter storage shed. Collecting a representative sample from these types of storage structures requires: (1) a shovel or solid manure sampling device such as the one shown in Figure 5, (2) a wheelbarrow, (3) a 5-gallon plastic bucket, and (4) a 1-quart plastic freezer bag.

Identify 10 to 12 widely dispersed points on the manure stack or litter pile that represent the average moisture content of the manure. The sampling points should include the center of the stack or pile as well as some near the edges. From each of these points, remove the top crust layer, collect 3 to 5 subsamples with the shovel or solid manure sampling device, and place the

collected litter or manure in the wheelbarrow. Thoroughly mix and crumble the collected subsamples, and place one shovelful in the plastic bucket. Repeat this process from each of the collection points. After collecting subsamples from each point, crumble and thoroughly mix all of the subsamples in the bucket. Fill the freezer bag two-thirds full (do not completely fill) with the composite sample, compress the air from the bag, and seal the bag. It is a good practice to tape over the seal to ensure that the bag does not come open during transit to the testing lab.

A key factor in obtaining a good sample from solid manure and litter storage facilities is to collect multiple subsamples from throughout the stack or pile at a time when the nutrient content is fairly stable. Unless the manure or litter is to be spread within the next few days, samples should not be collected from a freshly loaded or turned manure stack or litter pile. The nutrient content should stabilize within about two weeks of forming a new pile or turning an existing pile.

### Sampling Dry or Solid Manure from Paved Lots

In certain livestock production systems, animals are housed on paved feedlots where the manure that accumulates is scraped and hauled to the field (the “scrape-and-haul” method of manure utilization). The manure is typically removed from the paved area daily or several times each week. Equipment needed for collecting manure samples from paved lots includes: (1) a shovel, (2) a wheelbarrow, and (3) a 1-quart plastic freezer bag.

Approximately 10 to 12 subsamples should be collected from the paved lot. When identifying the areas of the paved lot to sample, be sure to choose areas that best represent the proportion of any variable conditions you observe, such as variations in moisture content, amount of bedding, etc. Each subsample should be collected by scraping the shovel across about 25 feet of the paved lot. After scraping across the paved lot, place the manure on the shovel in the wheelbarrow. Once all subsamples have been placed in the wheelbarrow, use the shovel to thoroughly mix and crumble the manure. Then, fill the freezer bag approximately two-thirds full with the composite sample. Compress any air remaining in the bag before sealing it.

Figure 4. An example of a composite sampling device for sampling manure effluent from lagoons.

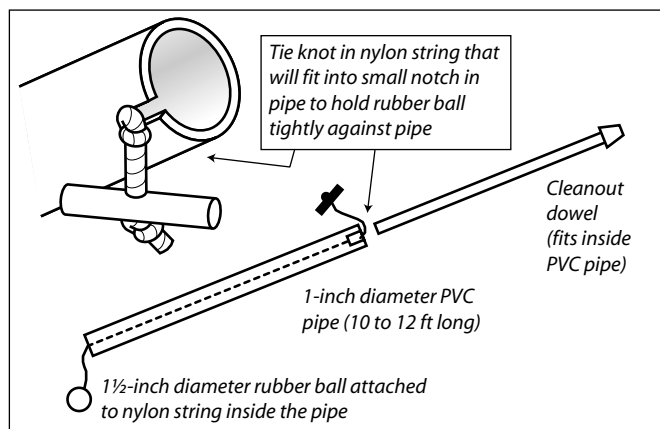
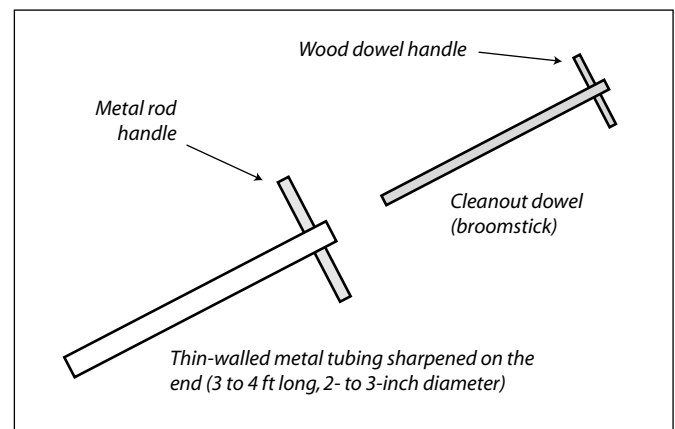

Figure 5. An example of a solid manure sampling device for sampling manure from dry manure stacks or litter piles.



### Sampling Poultry Litter before Full Cleanout

The point method and trench method are two options suitable for sampling poultry litter in the house. The objective of both methods is to obtain a sample that is representative of the litter within the entire house. Obtaining an adequate sample may take more than 30 minutes. Although this may seem an excessive amount of time, it is necessary to follow the proper procedures to ensure usable results.

#### Point method

Equipment needed to sample litter using the point method includes: (1) a 5-gallon plastic bucket, (2) a narrow, square-ended spade or a solid manure sampling device (Figure 5), and (3) a 1-quart plastic freezer bag.

The first step in the point method is to visually divide the house into three zones. For example, if the house runs in the north-south direction, divide the house into east, middle, and west zones (Figure 6). Walk the length of the building within a zone in a zigzag pattern and take 8 to 10 random subsamples with the spade (or solid manure sampling device) along your path. When taking each subsample, clear a small trench the width of the spade to a depth just above the dirt floor. Then take a 1-inch slice as the subsample, being sure to get equal amounts of litter the entire depth of the trench (Figure 7). Be sure to take a representative number of subsamples under feeders and waterers. Place each of the subsamples into the plastic bucket. This process should be repeated in each of the three zones.

Once subsamples have been collected from each zone, thoroughly mix and crumble all of the litter in the bucket. It may be necessary to pour the litter into a wheelbarrow or onto a piece of plywood to facilitate mixing. After thoroughly mixing, fill the freezer bag about two-thirds full with the composite sample. Be sure to compress the air from the bag before sealing it.

#### Trench method

Equipment needed to sample litter using the trench method includes: (1) a narrow, square-ended spade, (2) a wheelbarrow, (3) a 5-gallon plastic bucket, and (4) a 1-quart plastic freezer bag.

With the trench method, the building is divided into two areas—the brooder portion of the house and the non-brooder portion of the house (Figure 8). In approximately the middle of the brooder area, dig a trench the width of the spade from the centerline of the house to the sidewall. The trench should extend down through the litter to just above the dirt floor. Place all litter removed from the trench into the wheelbarrow. Repeat this process in the non-brooder portion of the house.

Depending on the width of the house and the depth of the trench, the amount of collected litter may exceed the capacity of the wheelbarrow. If this is the case, each time the wheelbarrow is two-thirds full, thoroughly mix and crumble the litter from the trenches. After mixing, remove one shovelful of litter and place it in the 5-gallon bucket. Empty the remainder of the litter from the wheelbarrow near the side of the trench. Repeat

Figure 6. An example of zone identifications and sampling patterns for the point method.

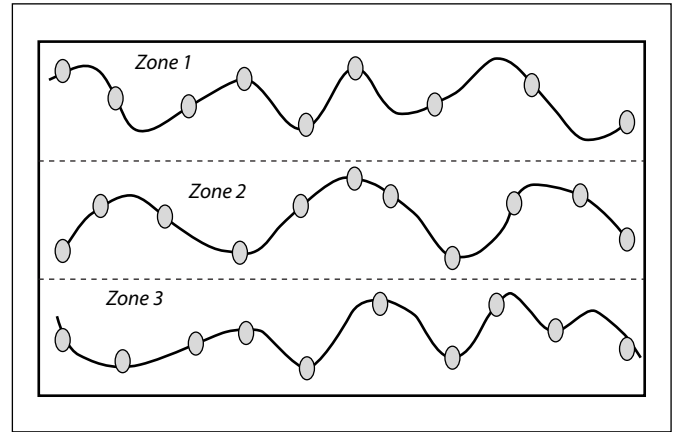

Figure 7. For the point method, use a square-ended spade to dig a small trench and take a subsample.

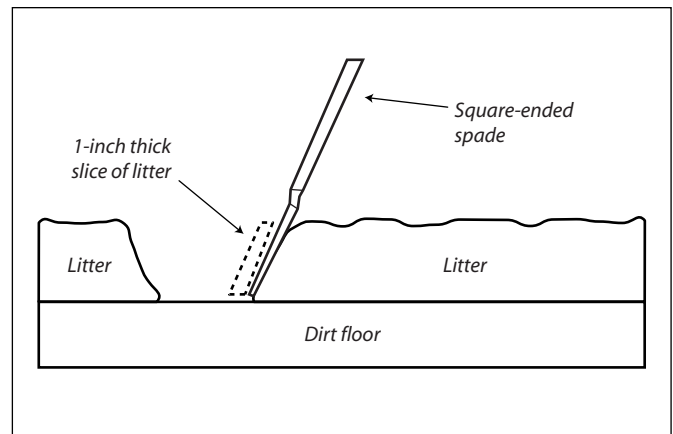
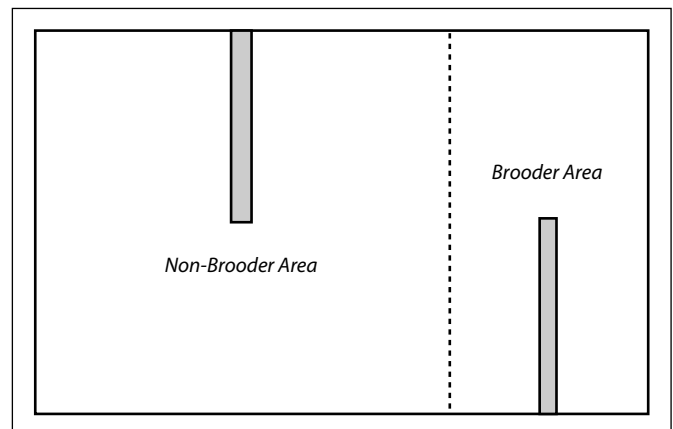

Figure 8. An example of zone identifications and sampling patterns for the trench method.



this process until both trenches have been completed. Then, thoroughly mix the litter collected in the bucket. Fill the freezer bag about two-thirds full with the composite sample, taking care to compress the air from the bag before sealing it.

### Sampling Poultry Litter during Full Cleanout

Equipment that will be needed to sample poultry litter when the entire house is being cleaned out includes: (1) a shovel, (2) a wheelbarrow, (3) a 5-gallon plastic bucket, and (4) a 1-quart plastic freezer bag.

Take one shovelful of litter from each truckload of litter removed and place it in the wheelbarrow. Depending on the volume of litter being removed, the amount of collected litter may exceed the capacity of the wheelbarrow. If this occurs, each time the wheelbarrow is two-thirds full, thoroughly mix the contents of the wheelbarrow and place one shovelful of litter in the 5-gallon bucket. Repeat this process until each truckload of litter has been sampled. Then, thoroughly crumble and mix the litter in the bucket. Fill the freezer bag about two-thirds full with the composite sample. Compress the air from the freezer bag before sealing it.

Either the point method or the trench method can also be used to sample litter from the house immediately before cleaning it out.

### Handling and Labeling Manure Samples

Ideally, manure samples should be mailed or delivered to the laboratory the day they are collected. If manure samples must be held longer than 24 hours, refrigerate or freeze the samples until they can be shipped to the testing lab. Do not let manure samples sit in hot areas such as the dashboard or trunk of a vehicle. If manure samples cannot be hand delivered to the testing lab, they should be mailed or shipped early in the week (Monday through Wednesday) to avoid arrivals on the weekend. Also, avoid shipping near holidays that could delay delivery.

All samples sent to the testing lab should be clearly labeled with a permanent marker. Include on the label the owner's or operation's name and address, sample identification number, date sample collected, and type of manure.

### Where to Send Manure Samples for Analysis

The Soil Testing Lab at the University of Kentucky Regulatory Services provides an analysis of animal manures that includes these factors:

- moisture (for solid manures)
- total nitrogen (N)
- phosphorus (reported as  $P_2O_5$ )
- potassium (reported as  $K_2O$ )
- calcium (Ca)
- magnesium (Mg)
- copper (Cu)
- zinc (Zn)
- iron (Fe), and
- manganese (Mn).

Nutrient concentrations are reported as pounds per ton for solid manures and as pounds per 1,000 gallons for liquid manures. The cost of the analysis is \$20.

To obtain an analysis from UK Regulatory Services, take manure samples to the local county Extension office. These offices have plastic bottles for liquid manure samples and an information sheet (also included in this publication) to fill out for the sample being submitted. The Extension office will send the sample to:

UK Regulatory Services  
Attention: Soil Lab  
103 Regulatory Services Building  
Alumni and Shawneetown Roads  
University of Kentucky  
Lexington, KY 40546-0275

Local county Extension agricultural agents can provide assistance with manure sampling, interpreting analysis results, and determining application rates. Two Extension resources—the Manure Management Planner Spreadsheet, a Microsoft® Excel-based computer program, and AGR-146, *Using Animal Manures as Nutrient Sources*—are available at local county Extension offices for calculating manure application rates based on manure analysis results and soil test recommendations.

Table 1 shows a partial listing of commercial laboratories that are also available for conducting analyses on manure samples. These labs can usually provide a detailed analysis of manure, including the different forms of nitrogen and most trace elements.

### Conversion Information for Manure Test Results

Because different labs report results in different ways, the following conversion chart may be helpful in interpreting individual results.

P (elemental phosphorus) x 2.27 = $P_2O_5$ (phosphate)
K (elemental potassium) x 1.2 = $K_2O$ (potash)
percent (%) x 20 = pounds per ton
percent (%) x 80 = pounds per 1,000 gallons
percent (%) x 2,254 = pounds per acre-inch
mg/L (milligrams per liter) x 0.002 = pounds per ton
mg/L (milligrams per liter) x 0.008 = pounds per 1,000 gallons
mg/L (milligrams per liter) x 0.225 = pounds per acre-inch
pounds per ton x 4.17 = pounds per 1,000 gallons
pounds per 1,000 gallons x 0.2398 = pounds per ton
1 gallon = 8.34 pounds
1 acre-inch = 27,154 gallons
mg/L (milligrams per liter) = ppm (parts per million)

**Table 1.** Commercial Animal Manure Testing Laboratories<sup>a</sup>

<b>Laboratory</b>	<b>Types of Analyses<sup>bc</sup></b>
A&L Analytical Laboratories, Inc. 411 North 3rd Street Memphis, TN 38105 Phone: (901) 526-1031 Web site: www.al-labs.com	(1) Basic M1 analysis – moisture, total N, P <sub>2</sub> O <sub>5</sub> , K <sub>2</sub> O (2) Basic M2 analysis – moisture, total N, P <sub>2</sub> O <sub>5</sub> , K <sub>2</sub> O, Ca, Mg, Na, S, Fe, Al, Mn, Cu, Zn
Chemical Services Lab 3303 Industrial Parkway Jeffersonville, IN 47130 Phone: (812) 280-1090	(1) NPK analysis – total N, P <sub>2</sub> O <sub>5</sub> , K <sub>2</sub> O (2) NPK analysis plus trace elements – total N, P <sub>2</sub> O <sub>5</sub> , K <sub>2</sub> O, Ca, Mg, Fe, Mn, Cu, Zn, SO <sub>4</sub>
Holmes Laboratory, Inc. 3559 U.S. Rt. 62 Millersburg, OH 44654 Phone: (330) 893-2933 Web site: www.holmeslab.com	(1) Test K – total solids, moisture, pH, total N, ammonium N (NH <sub>4</sub> ), P <sub>2</sub> O <sub>5</sub> , K <sub>2</sub> O, Ca, P, Mg, K (2) Test M – total solids, moisture, pH, total N, ammonium N (NH <sub>4</sub> ), P <sub>2</sub> O <sub>5</sub> , K <sub>2</sub> O, Ca, P, Mg, K, Na, Cu, Mn, Zn, Fe
Iowa Testing Laboratories, Inc. Highway 17 North P.O. Box 188 Eagle Grove, IA 50533 Phone: (515) 448-4741 Web site: www.swine.net/itl.htm	(1) Standard analysis – moisture, total N, P <sub>2</sub> O <sub>5</sub> , K <sub>2</sub> O (2) Analysis of trace elements – Ca, P, K, Mg, S, Zn, Mn, Cu, Fe, Co, Na (3) Complete analysis – moisture, total N, P <sub>2</sub> O <sub>5</sub> , K <sub>2</sub> O, Ca, Mg, S, Zn, Mn, Cu, Fe, Co, Na
Spectrum Analytic, Inc. P.O. Box 639 1087 Jamison, Road Washington Courthouse, OH 43160 Phone: (800) 321-1562 Web site: www.spectrumanalytic.com	(1) NPK analysis – total N, P <sub>2</sub> O <sub>5</sub> , K <sub>2</sub> O, moisture/DM (2) Complete analysis - total N, ammonium N (NH <sub>4</sub> ), nitrate N (NO <sub>3</sub> ), total P <sub>2</sub> O <sub>5</sub> , available P <sub>2</sub> O <sub>5</sub> , K <sub>2</sub> O, pH, moisture/dry matter, Ca, Mg, S, B, Cl, Cu, Fe, Mn, Zn, Al, As, Ba, Cd, Cr, Co, Pb, Hg, Mo, Ni, Se, Si, Ag

*It is recognized that this is not an all-inclusive list of commercial laboratories. Neither endorsement of companies or their services mentioned is intended, nor is criticism implied of similar companies or their services not mentioned.*

<sup>a</sup> Many commercial laboratories will provide sample containers for manure samples that are being sent to their labs. Contact the specific commercial testing lab to learn if sample containers are available.

<sup>b</sup> The cost of manure analyses will vary among commercial laboratories. However, most basic manure analyses (total N, P<sub>2</sub>O<sub>5</sub>, and K<sub>2</sub>O) will typically range from approximately \$20 to \$40, and more complex analyses (additional forms of N and more complete analysis of trace elements) will usually range from approximately \$40 to \$75. Contact the specific testing lab for a current schedule of fees.

<sup>c</sup> Many of the commercial laboratories mentioned conduct additional analyses that are not listed here (such as ammonium N, nitrate N, carbon:nitrogen ratio, organic matter, solids, electrical conductivity, etc.). Contact the specific testing lab of interest for a more complete listing of available analyses.

UNIVERSITY OF KENTUCKY  
 College of Agriculture Cooperative Extension Service  
 AGRICULTURAL ANIMAL MANURE SAMPLE INFORMATION SHEET

Department of Agronomy

Division of Regulatory Services

<p><b>Section I. Owner Information</b></p> <p>DATE SAMPLED: ____ / ____ / ____</p> <p>NAME: _____</p> <p>ADDRESS: _____</p> <p>CITY: _____ STATE: ____ ZIP: ____</p> <p>PHONE: _____</p> <p>Owner's Sample ID:</p> <table border="1" style="width: 100%; height: 20px; border-collapse: collapse;"> <tr> <td style="width: 25%;"></td> <td style="width: 25%;"></td> <td style="width: 25%;"></td> <td style="width: 25%;"></td> </tr> </table>					<p style="text-align: center;"><b>Section II. Test to be Made</b></p> <p><input type="checkbox"/> Routine (Total N, P<sub>2</sub>O<sub>5</sub>, K<sub>2</sub>O, and moisture for solids)</p>	<p style="text-align: center;"><b>Section VI. Lab Use</b></p> <hr/> <p style="text-align: center;"><b>Section VII. County</b></p> <table border="1" style="margin: 0 auto; border-collapse: collapse;"> <tr> <td style="width: 25%; height: 25px;"></td> <td style="width: 25%;"></td> <td style="width: 25%;"></td> <td style="width: 25%;"></td> </tr> </table> <p style="text-align: center;">County Code</p> <table border="1" style="margin: 0 auto; border-collapse: collapse;"> <tr> <td style="width: 25%; height: 25px;"></td> <td style="width: 25%;"></td> <td style="width: 25%;"></td> <td style="width: 25%;"></td> </tr> </table> <p style="text-align: center;">County Sample No.</p>								
<p><b>Section III. Type of Animal Manure</b></p> <p> <input type="checkbox"/> Poultry      <input type="checkbox"/> Solid  <input type="checkbox"/> Dairy        <input type="checkbox"/> Liquid  <input type="checkbox"/> Swine  <input type="checkbox"/> Beef         </p>		<p style="text-align: center;"><b>Section VIII. Lab Use Only</b></p> <p>Billing Code _____</p>												
<p><b>Section IV. Animal Waste Application History</b></p>   														
<p><b>Section V. Other Information</b></p>   														

Paid \_\_\_\_\_

\_\_\_\_\_  
Signature of Extension Agent

