

260543D01 UNDERGROUND DUCTS & RACEWAYS

Construction Details - Electrical Manhole

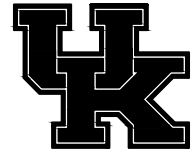

MANHOLE GENERAL NOTES:

1. MANHOLES MAY BE POURED-IN-PLACE OR PRECAST.
2. FOR POURED-IN-PLACE MANHOLES, BOTTOM IS ONE POUR, SIDES ARE ONE POUR, AND TOP IS ONE POUR, ALL WITH KEYED JOINTS, AND APPROPRIATE WATER STOP.
3. PRECAST MANHOLES SHALL BE A BOTTOM HALF AND A TOP HALF WITH KEYWAY BUILT INTO EACH HALF. AT INSTALLATION BOTTOM KEYWAY SHALL BE FILLED HALFWAY WITH WATER STOP CAULK ALL WAY ROUND THE BOTTOM HALF BEFORE PLACING TOP HALF IN PLACE.
4. PROVIDE A HIGH VENT AND A LOW VENT. HIGH VENT IS OUTLET, LOW VENT IS INLET. MATERIAL TO BE RCP OR PVC.
5. TOTAL SIZE OF MANHOLE SHALL BE 12'x8'x7' INSIDE (UNLESS NOTED OTHERWISE).
6. PROVIDE PULLING EYES, ONE IN THE WALL OPPOSITE EACH DUCT BANK AND ONE RECESSED IN THE CENTER OF THE MANHOLE FLOOR.
7. PROVIDE BELL ENDS ON ALL CONDUITS.
8. ALL CONDUIT AND BOXES SHALL BE SCH 40 PVC.
9. ELECTRICAL DISCONNECTS SHALL BE NEMA 4 AND DEVICES SHALL BE NEMA 3R.
10. PROVIDE TWO VAPOR PROOF, 5000° K, LED LIGHT FIXTURES AS INDICATED. FIXTURES SHALL BE A SYLVANIA VAPOR TIGHT LED SERIES SIMILAR TO ITEM NUMBER 74531 OR EQUAL.
11. EXHAUST FAN TO MEET OSHA REQUIREMENTS SHALL BE SIMILAR TO GREENHECK FAN CORP MODEL NUMBER SE1-12-432-D OR EQUAL. CONNECT FAN TO OPERATE WHEN LIGHT SWITCH IS TURNED ON.
12. PROVIDE A NON-GFI SINGLE USE RECEPTACLE WITH WEATHERPROOF COVER FOR SUMP PUMP USE.
13. PROVIDE A GFI DUPLEX RECEPTACLE WITH WEATHERPROOF COVER FOR GENERAL USE.
14. PROVIDE AND INSTALL CABLING RACKS ON ALL FOUR WALLS FROM TOP TO BOTTOM WITH BRACKETS AS REQUIRED TO SUPPORT CABLING. RACKS SHALL BE COMPRISED OF GALVANIZED STEEL UNISTRUT EMBEDDED INTO THE CONCRETE WALLS.
15. MANHOLE REBAR SPACING AND CONCRETE THICKNESSES ARE ESTIMATED. MANHOLE IS TO BE CONSTRUCTED BASED ON THE DIMENSIONS AND FEATURES OUTLINED IN THESE DETAILS. THE SHOP DRAWINGS SHALL BE STAMPED BY A STRUCTURAL ENGINEER REGISTERED IN THE STATE OF KENTUCKY.
16. CABLES ARE TO BE SUPPORTED FROM BRACKETS WITH PLASTIC OR FIBERGLASS DONUT STYLE INSULATORS TO ENCOMPASS ALL FOUR CABLES TOGETHER PER CIRCUIT.
17. H-20 TRUCK LOADING ON ALL MANHOLES.

260543D01 UNDERGROUND DUCTS & RACEWAYS

Construction Details - Electrical Manhole

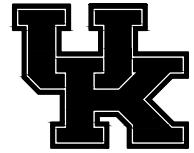

MANHOLE GENERAL NOTES (cont.):

18. COVER SHALL BE 32" DIAMETER MINIMUM. 32" DIA. CLEAR OPENING MUST BE MAINTAINED. HOE MC-680 OR MC-780 ROUND MANHOLE FRAME AND COVER.
19. WATERPROOF EXTERIOR SURFACES BELOW GRADE PORTION OF SIDES AND TOPS OF MANHOLES. SEE DETAILS.
20. ALL DUCT BANKS SHALL BE DOWELED INTO THE MANHOLE WALL WHICH THEY ENTER WITH AT LEAST SIX 12" LONG #4 REBAR.
21. MANHOLE LADDER AND LADDERS EXTENSIONS SHALL BE FACE MOUNT ALUMINUM WITH LADDER EXTENSION (HALLIDAY PRODUCTS LD1 AND LE1 OR EQUAL).
22. PROVIDE INJECTABLE HYDROPHOBIC WATERSTOP AROUND ALL UNDERGROUND PENETRATIONS THROUGH VAULT.
23. ALL POST-INSTALLED ANCHORS SHALL BE OF STAINLESS STEEL AND RATED FOR ATTACHMENT TO CRACKED CONCRETE.
24. PROVIDE DIELECTRIC SEPARATOR BETWEEN ALL ALUMINUM AND CONCRETE.
25. ANY EXCAVATION THAT UNDERMINES BELOW DUCT BANK MORE THAT 15 FOOT CONTINUOUSLY SHALL BE SHORED.
26. EXCAVATIONS AROUND VAULTS SHALL BE BACKFILLED IN 8-INCH MAXIMUM DEPTH LOOSE LIFTS AND CONSOLIDATED TO 98 PERCENT OF THE ASTM D698 MAXIMUM DRY UNIT WEIGHT. OPEN GRADED STONE BACKFILLS SHALL BE PLACED IN 8 INCH MAXIMUM LIFTS AND TAMPED IN PLACE.
27. ALL REBAR SHALL BE CHAIRED INTO PLACE.
28. CONTRACTOR SHALL PROVIDE FOR AN INDEPENDENT TESTING AGENCY MEETING THE REQUIREMENTS OF ASTM E329 TO PROVIDE CONTINUOUS OBSERVATION OF CONCRETE PLACEMENT TO VERIFY PROPER PLACEMENT TECHNIQUES AND TO PROVIDE FOR COMPRESSIVE STRENGTH TESTS OF (VAULT ONLY) CONCRETE PER ASTM C 31 AND C 39 WITH ONE SAMPLE FOR EACH DAYS POUR LESS THAN 25 CU YD, PLUS ONE SET FOR EACH ADDITIONAL 50 CU YD. SUBMIT ALL REPORTS TO OWNER AND ENGINEER OF RECORD.

260543D03 UNDERGROUND DUCTS & RACEWAYS Construction Details - Electrical Manhole Section

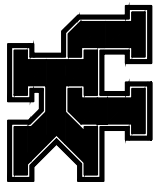

FANS																
SYMBOL	MANUFACTURER	MODEL	TYPE	SONES	CFM	S.P. IN.	W.G. IN.	FAN RPM	BHP	MOTOR				WHEEL		REMARKS
										HP	RPM	PH	VOLTS	TYPE	DIAM.	
EF-1	GREENHECK	SE1-14-440-B6	*1	7.6	837	0.30		1160	0.2	1/6	1160	1	115	---	---	*2 *3

- REMARKS:
 *1 SIDE WALL DIRECT DRIVE EXHAUST FAN.
 *2 GALVANIZED STEEL CONSTRUCTION WITH ALUMINUM BLADE PROPELLER AND CORROSION RESISTANT FASTENERS.
 *3 PROVIDE OSHA APPROVED MOTOR SIDE GUARD.

CAST NOTE: 12" CAST IRON VENT FRAME AND COVER FLUSH WITH CONCRETE WALK, PAVEMENT OR GRADE.
 PROVIDE VENT COVER CATALOG NO. MCB-82B BY J.R. HOE AND SONS, MIDDLESBORO, KY OR U-1610- 2 RING AND U3610-2 GRATE BY EAST JORDAN IRON WORKS.

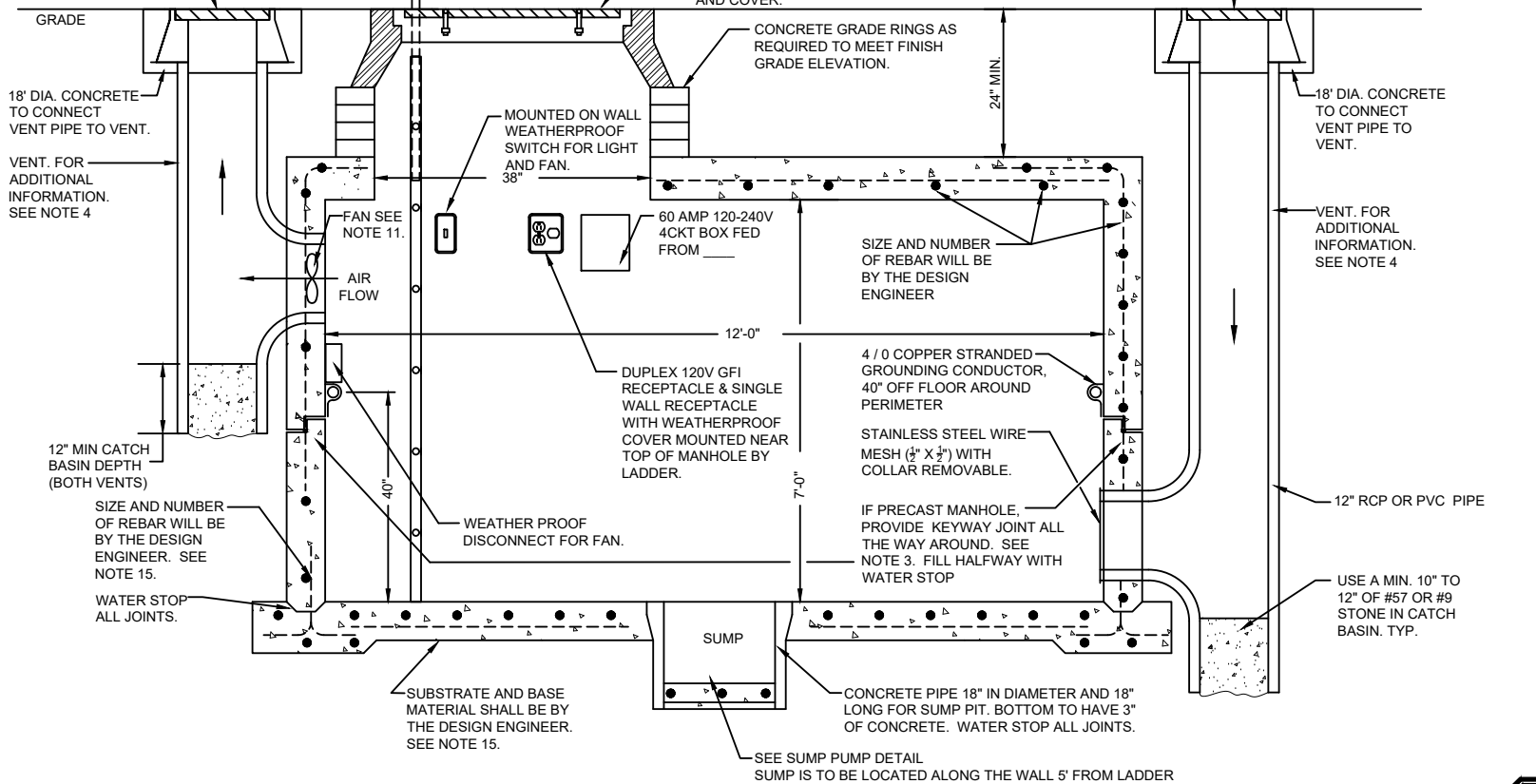

SECTION A-A THROUGH ELECTRIC MANHOLE

NO SCALE

ALL LOW VOLTAGE WIRING IN 1" PVC MINIMUM.

260543D05 UNDERGROUND DUCTS & RACEWAYS

Construction Details - Manhole Sump Pump

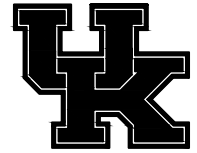

SUMP PUMP FOR VAULT AND MANHOLE
 NOTE: SUMP-PUMP -- ZOELLER PUMP MODEL NO 2137,
 1½" SUBMERSIBLE SUMP PUMP RATED FOR HIGH TEMPERATURES - 200°F INTERMITTED,
 50 GPM @ 15 FT. HEAD, 0.5 HP, 120V/1Ø POWER. PROVIDE WITH FLOAT SWITCH. PUMP
 SHALL BE SELF-VENTING.

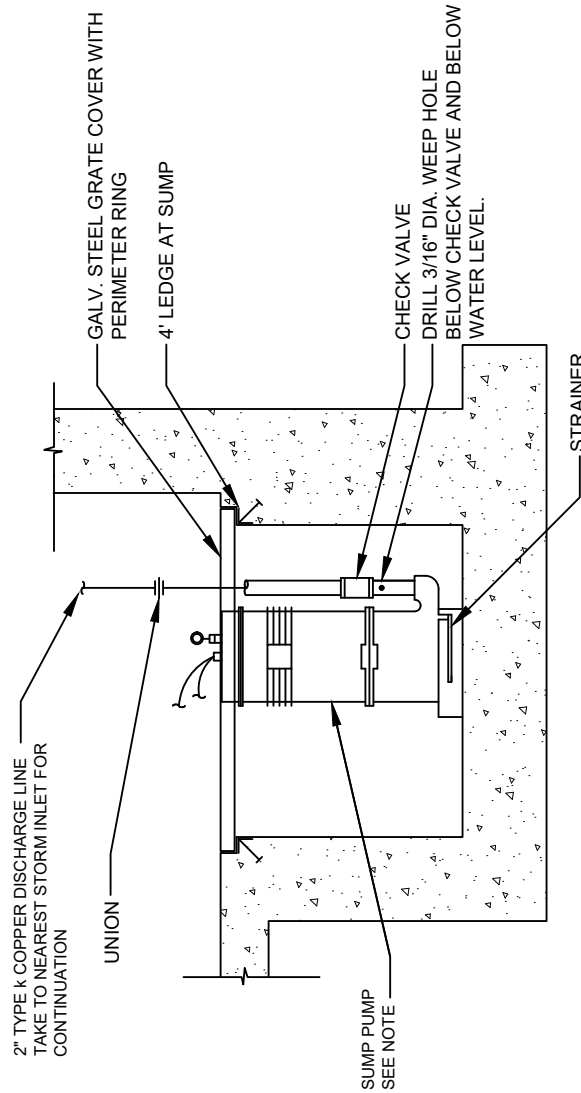

MANHOLE SUMP PUMP DETAIL

NO SCALE

260543D06 UNDERGROUND DUCTS & RACEWAYS

Construction Details - Typical Manhole Waterproofing

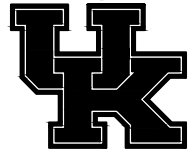

****NOTE: THIS WATERPROOFING METHOD IS TO BE USED ON BOTH CAST-IN-PLACE AND PRECAST MANHOLE STRUCTURES.**

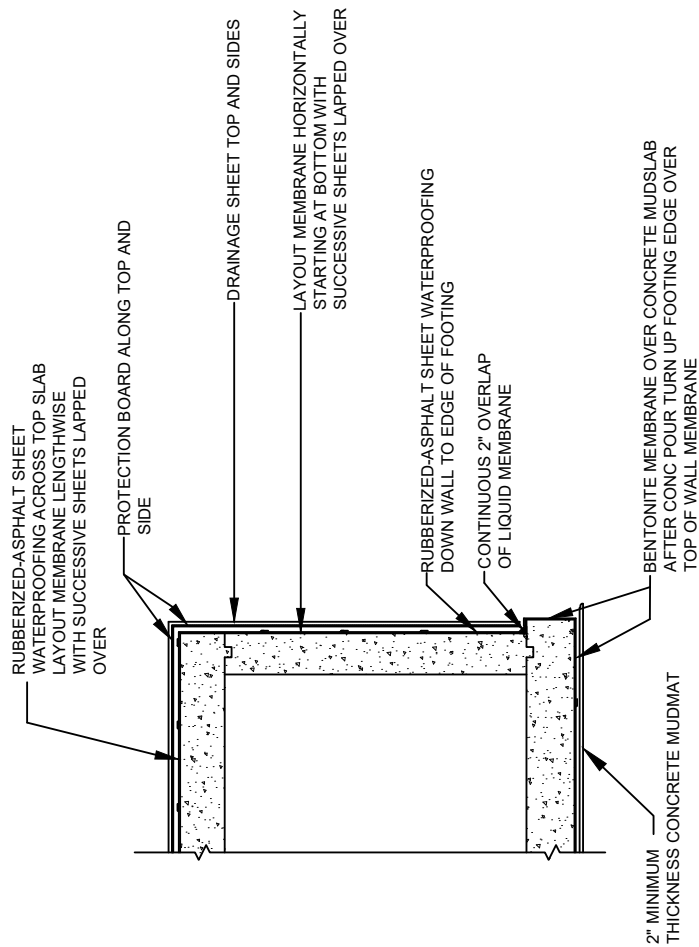

TYPICAL WATERPROOFING DETAIL

NO SCALE

260543D07 UNDERGROUND DUCTS & RACEWAYS

Construction Details - DUCT BANK Installation Detail

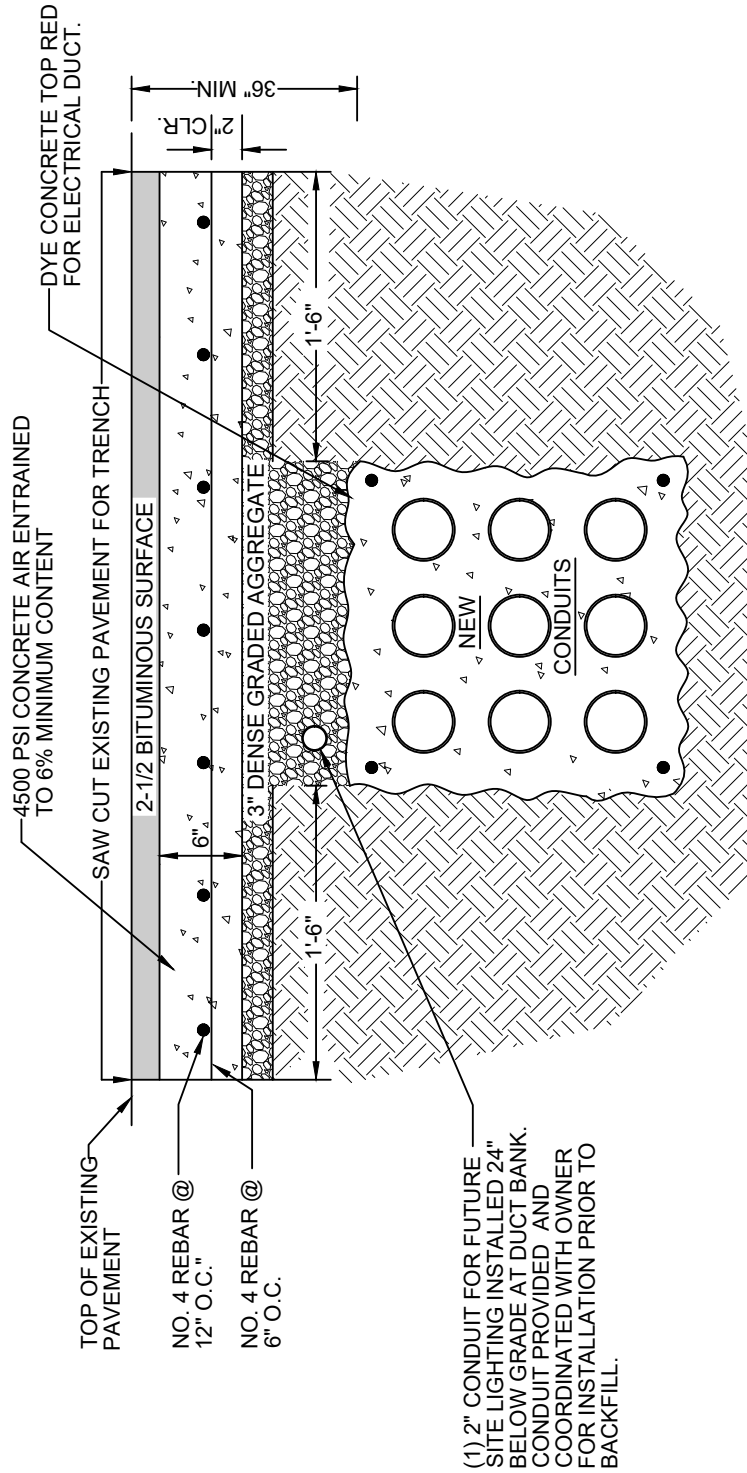

TYPICAL INSTALLATION DETAIL OF DUCT BANK UNDER ROADWAY OR PARKING LOT

NO SCALE

NOTES:

1. SEE SITE UTILITY PLANS FOR NUMBER AND SIZE OF CONDUITS IN EACH DUCT BANK. SEE ALSO DUCT BANK SECTIONS FOR ADDITIONAL INFORMATION.
2. ALL DUCT BANKS SHALL BE DOWELED INTO THE MANHOLE WALL WHICH THEY ENTER WITH AT LEAST SIX 12-INCH LONG #4 REBAR.
3. PROVIDE PROTECTIVE FENCE IF TRENCH IS OUTSIDE CONSTRUCTION AREA.
4. WATERPROOF DOWEL PENETRATIONS.

260543D08 UNDERGROUND DUCTS & RACEWAYS

Construction Details - DUCT BANK Installation Detail

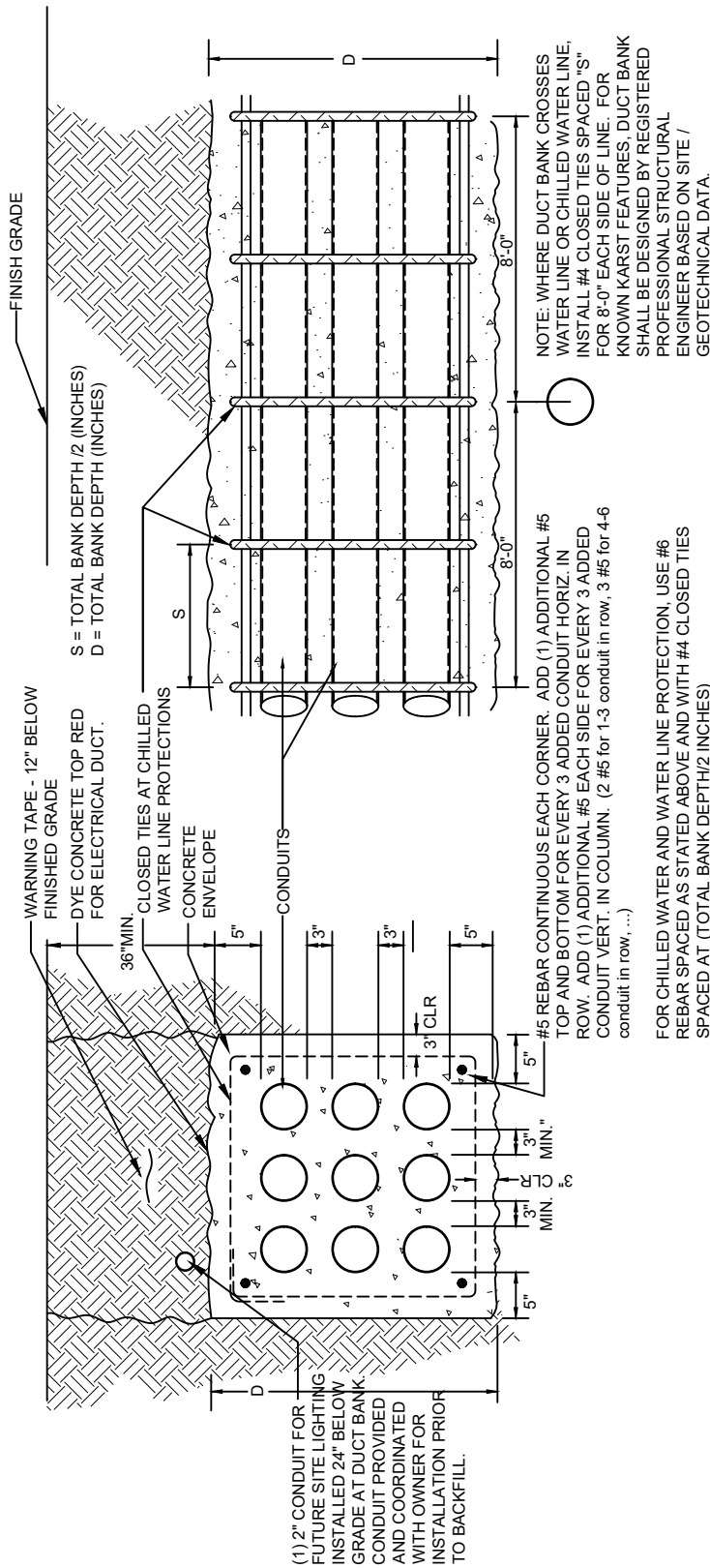
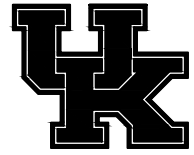

TYPICAL PRIMARY ELECTRICAL DUCT BANK INSTALLATION DETAIL

NO SCALE
 DUCT BANKS AND CONDUIT SYSTEMS ARE ELECTRICAL FACILITIES FOR POWER DISTRIBUTION. IN ORDER FOR THE ELECTRICAL SYSTEM TO PERFORM AT ITS FULL CAPACITY, THESE SYSTEMS SHALL BE CONSTRUCTED IN A NEAT AND WORKMANLIKE MANNER TO ENSURE THAT:

1. ALL JOINTS ARE TIGHTLY SEALED AGAINST WATER INTRUSION.
2. ALL JOINTS ARE PROPERLY ALIGNED, SQUARE AND HAVE ADEQUATE CURE TIME.
3. ALL EDGES ARE DEBURRED AND BEVELED TO PREVENT DAMAGE TO CABLES.
4. CONDUIT RUNS ARE ADEQUATELY SUPPORTED SO THEY DO NOT BECOME DISTORTED DURING ENCASEMENT OR BACKFILL.
5. CONCRETE TO BE 3,000 PSI DESIGN COMPRESSIVE STRENGTH WITH ASTM C150 CEMENT, MAXIMUM 20% TYPE C OR F FLYASH, 1/2" MAXIMUM AGGREGATE SIZE, AND POTABLE WATER. REINFORCING TO BE ASTM A615, GRADE 60 LAPPED MINIMUM 48" FOR #5 AND 56" FOR #6. PROVIDE MINIMUM 3" CLEAR BETWEEN CONDUIT AND 3" COVER TO TRENCH/ EARTH.
6. DEPOSIT CONCRETE CONTINUOUSLY IN ONE LAYER OR IN HORIZONTAL LAYERS OF SUCH THICKNESS THAT NO NEW CONCRETE IS PLACED ON CONCRETE THAT IS HARDENED ENOUGH TO CAUSE SEAMS OR PLANES OF WEAKNESS. CONSOLIDATE PLACED CONCRETE BY MECHANICAL VIBRATING EQUIPMENT USING EQUIPMENT AND PROCEDURES COMPLYING WITH ACI 301. DO NOT USE VIBRATORS TO TRANSPORT CONCRETE INSIDE TRENCH. INSERT AND WITHDRAW VIBRATORS AT UNIFORM SPACED LOCATIONS NO FARTHER THAN THE VISIBLE EFFECTIVENESS OF THE MACHINE. LIMIT DURATION OF VIBRATION TO TIME NECESSARY TO CONSOLIDATE CONCRETE WITHOUT CAUSING MIX TO SEGREGATE.
7. DUCTS SHALL BE TEMPORARILY HELD IN PLACE WITH HIGH DENSITY POLYETHYLENE SPACERS WITH MINIMUM 50% OPEN AREA TO ALLOW FOR FLOW AND INTERLOCK OF CONCRETE ACROSS SPACER.